

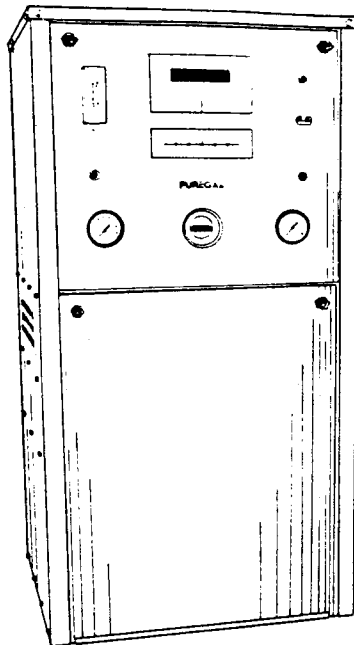

**PUREGAS  
INSTRUCTION MANUAL  
FOR MODELS P-3100-DCO  
AND P-4200-DCO AIR DRYERS**



A Unit of Penn Central Corp.

**Mopeco/Puregas Headquarters:** P.O. Box 666, 5600 W. 88th Avenue,  
Westminster, Colorado 80030, (303) 427-3700 or (800) 521-5351

**Satellite Locations:**

P.O. Box 579, Hughes Ford Rd., Frederick, MD 21701, (301) 662-6262

2249B Davis Ct., Hayward, CA 94545-1113, (510) 785-0821

2840 Ficus St., Pomona, CA 91766, (909) 591-4802

5220 Minola Dr., Lithonia, GA 30038, (404) 981-7470

2121 Research Dr., Fort Wayne, IN 46808, (219) 482-4401

Gencab of Canada Ltd., P.O. Box 533, 42 Niagara St.,

Hamilton, Ontario, Canada L8N 3K5, (416) 529-7047

## PREFACE

This instruction manual is produced for the benefit of our customers. It is intended to provide basic information that will enable our customers to install, maintain, and service Puregas Air Dryers economically, capably, and with minimum delay. Careful observation of these instructions and maintenance procedures will ensure maximum life and efficiency of the unit.

This manual should be read thoroughly before installing, operating, or servicing the air dryer in order to acquaint the operator or mechanic with the unit and its use, as well as proper operating and repair procedures. This will, in turn, minimize the possibility of damage to the unit due to improper operation, handling, or disassembly.

Please direct all inquiries to:

General Cable Company  
Apparatus Division  
5600 W. 88th Avenue  
Westminster, Colorado 80030  
(303) 427-3700

NO PART OF THIS TECHNICAL MANUAL MAY BE REPRODUCED WITHOUT THE EXPRESSED WRITTEN CONSENT OF GENERAL CABLE COMPANY.

## LIMITED WARRANTY AGREEMENT

Puregas air dryers carry a two-year warranty against defective workmanship and material. This period starts at date of shipment. Not included are components subject to normal replacement during a year's operating time. These parts include but are not limited to electrical components, pressure switches, pressure regulators and air compressors which carry a one year warranty.

On refrigeration type dryers, the basic refrigeration circuit carries a five-year warranty. This warranty covers the refrigeration compressor, refrigeration tubing and coils but NOT the thermostat, thermometer, or fan motor.

No claims for labor in replacing defective parts or for consequential damages will be allowed. Replacement parts will be invoiced in the regular way with invoices subject to adjustment after the parts claimed defective are examined at our factory. In addition, no material or parts will be accepted at our factory for in-warranty repairs or credit without previous authorization from Puregas Division, General Cable Company.

Responsibility for damages incurred in transit will be borne by the user and the user in turn should file any damage claim against the carrier. All warranty items are F.O.B. our plant. Freight charges are the responsibility of the user.

This warranty shall not apply to any air dryer which shall have been repaired or altered in any way by anyone other than the Puregas Division, General Cable Company so as to affect, in our judgement, its proper functioning or reliability, neither will it apply to a dryer which has been subjected to misuse, negligence or accident.

THE INSTALLING OF PARTS PURCHASED FROM OTHER THAN GENERAL CABLE COMPANY WILL VOID THE WARRANTY ON OUR AIR DRYERS.

**AIR DRYER INSTRUCTION MANUAL  
FOR  
PUREGAS MODELS P-3100/P-4200 DCO**

**TABLE OF CONTENTS**

<u>SECTION</u>	<u>DESCRIPTION</u>	<u>PAGE</u>
1.0	GENERAL .....	1
2.0	INSPECTION AND START UP .....	2
2.1	Initial Inspection .....	2
2.2	Installation .....	2
2.3	Electrical Hookup .....	3
2.4	Start-up .....	3-4
3.0	TEST ROUTINE .....	4
3.1	Low Pressure Alarm Test .....	4
3.2	High Pressure Alarm Test .....	4
3.3	Humidity Condition Test .....	5
3.4	Humidity Alarm Test .....	6
3.5	Compressor Performance Test .....	6-7
4.0	DEMONSTRATION OPERATION .....	8
5.0	ALARM SUMMARY .....	9
6.0	PRINCIPLES OF OPERATION .....	10
6.1	Air System .....	10
6.2	Air Compressor .....	10
6.3	Puregas Heatless Dryer (Dehydrator) .....	10-11
6.4	Capacity Control Valve .....	12
6.5	Pressure Switch and Storage Tank .....	12
6.6	Pressure Regulator .....	12
6.7	Humidity Sensing Tube .....	12
6.8	Humidity Bypass Solenoid Valve .....	12
6.9	High-Low Pressure Switch .....	13
6.10	Flowmeter and Low Pressure Outlet .....	13
7.0	SOLID STATE CIRCUITRY .....	14
7.1	Logic Board .....	14
7.2	Display Board .....	14
7.3	Humidstat Board and Remote Visual Display .....	15
7.4	Solid State Relay Board Assembly .....	16

## TABLE OF CONTENTS

(Continued)

<u>SECTION</u>	<u>DESCRIPTION</u>	<u>PAGE</u>
8.0	GENERAL MAINTENANCE .....	18
8.1	Air Compressor Safety Valve .....	19
8.2	Air Compressor Pressure Switch .....	19-20
8.3	High-Low Pressure Alarm .....	20-20A
8.4	Capacity Control Valve .....	21
8.5	Air Compressor Maintenance .....	21,22,23,24
8.6	Heatless Dryer Maintenance .....	25,26,26A,27,27A
8.7	Miscellaneous Maintenance .....	28
8.8	Pressure Regulator Maintenance .....	28
8.9	Bypass Solenoid Valve .....	28
8.10	Humidity Alarm Calibration .....	28
9.0	MAINTENANCE MATRIX AND PARTS SUMMARY .....	34
9.1	Recommended Spare Parts List .....	35
10.0	TROUBLESHOOTING INFORMATION GUIDE .....	36
10.1	Troubleshooting Guide .....	37

PHOTOGRAPHS, TABLES AND DRAWINGS

TITLE	FIG.	PAGE
Outline Dimensions .....	1	1
Table of Characteristics .....	2	1
Humidity Time Delay Switch .....	3	5
Compressor Performance Time Delay Switch .....	4	7
Puregas Heatless Theory .....	5	11
Flow Diagram - P-3100 and P-4200 DCO .....	6	13
Logic Board .....	7	14
Humidistat Board .....	8	15
(Top) SSR Board .....	9	16
(Bottom) SSR Board .....	10	16
Wire Diagram - P-3100 and P-4200 DCO .....	11	17
Air Compressor Pressure Switch .....	12	20
High-Low Pressure Switch .....	13-13A	20-20A
Air Compressor Trouble Shooting Guide .....	14	22
Exploded View of Air Compressor and Motor Assembly .....	15	24
Exploded View of Puregas Heatless Dryer (Dehydrator) .....	16-16A	26-26A
Exploded View of Pressure Regulator .....	17	29
Exploded View of Solenoid Valve .....	18	30
Air Dryer Unit, Front View .....	19	31
Air Dryer Unit, Top Compartment Front View .....	20	32
Air Dryer Unit, Top Front Door .....	21	33
Humidity Alarm Guide .....	22	39
Low Pressure Alarm Guide .....	23	40
High Pressure Alarm Guide .....	24	41
Compressor Performance Alarm Guide .....	25	42

**INSTRUCTION MANUAL  
MODELS P-3100 and P-4200 DCO  
HEATLESS TYPE AIR DRYER UNITS**

**1.0 GENERAL**

This instruction manual covers the description, installation, start-up, operation, troubleshooting, maintenance and service part identification for the P-3100 and P-4200 DCO Air Dryers. They are self-contained, free-standing, assembled and tested units, designed for indoor installation and application at a central office location. Electric power supply input, alarm socket and air tube outputs are the only external connections required.

The general service application for these units is to provide processed air at a continuous and constant rate for pressure cable, wave guides or other devices requiring a dry air supply.

The ratings, characteristics and features for the Air Dryer Units are as specified in figure 2.

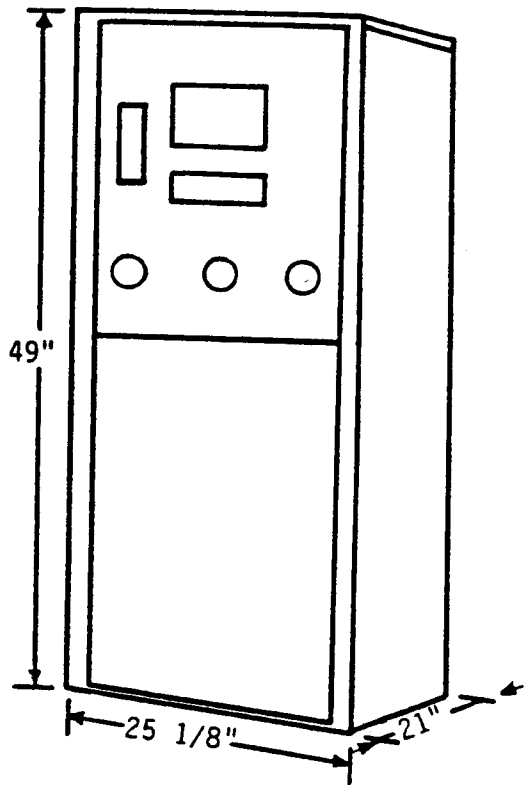

Figure 1 - Outline Dimensions

<b>Air Dryer Characteristics</b>		
MODEL	P-3100 DCO	P-4200 DCO
Normal Output Capacity	1800 SCFD*	2600 SCFD*
Emergency Output Capacity	3100 SCFD*	4200 SCFD*
Output Pressure	Adjustable 0-20 PSIG (flow meter calibrated for 10 PSIG output)	Adjustable 0-20 PSIG (flow meter calibrated for 10 PSIG output)
Noise Level	56 dba @ 3 feet and 53 dba @ 10 feet	56 dba @ 3 feet and 53 dba @ 10 feet
Electrical Requirements	115 VAC single phase 12 amps, 60 HZ	115 VAC single phase 14.25 amps, 60 HZ
Electrical Options	Available For World Wide Applications	
Dryer Type	Heatless Desiccant and oilless compressor	Heatless Desiccant and oilless compressor
Outlet Air Humidity	Less than 2% RH	Less than 2% RH
Ambient Temperature Range	+32° F. to +120° F.	+32° F. to +120° F.
Shipping Weight	276 lbs.	276 lbs.
Dimensions	Height: 49" Width: 25 1/8" Depth: 21"	Height: 49" Width: 25 1/8" Depth: 21"
Heat Dissipation	3400 BTU's/hr.	4600 BTU's/hr.

\*Standard Cubic Feet Per Day

**FIGURE 2  
TABLE OF AIR DRYER CHARACTERISTICS**

**SECTION 2**  
**INSPECTION AND START-UP**

**Caution**

It is extremely important the start-up procedure is performed in the following sequence:

**2.1. Initial Inspection**

2.1.1. Remove the lower front door and open the upper instrument panel. Carefully inspect both the exterior and interior of the air dryer for any shipping damage.

2.1.2. Any damage must be brought to the immediate attention of the carrier.

2.1.3. The following items will be secured in the air compressor compartment accessory bag:

1 Each	P-1290	Bushing
1 Each	P-1328	Connector - Male
2 Each	P-3986	Element
1 Each	P-5000-3-19	Bag, Cloth
1 Each	P-5000-8-38	Plug, Alarm

2.1.4. Close the upper instrument panel and install the lower panel before moving unit to the permanent location.

**2.2. Installation**

2.2.1. The unit should be installed in an environment free of abrasive dust and chemicals.

2.2.2. The optimum temperature range is between 40° F. and 85° F. Although the unit will operate in temperatures over 100° F., the operating life of the components decreases dramatically.

2.2.3. Leveling feet are provided under each corner of the air dryer. The air dryer must be properly leveled to prevent excess vibration and insure proper alignment of the access panels.

2.2.4. **Remove Shipping Blocks.** The shipping blocks must be removed from the air compressor mounting assembly. Removal of these blocks will permit the air compressor to "float" freely on the four rubber vibration pads.

2.2.5. Failure to remove the shipping blocks will damage the air compressor vibration mounts.

### 2.3. Electrical Hookup

2.3.1. The air dryer operates on 115 VAC, 1 phase, 60 hz

**Important - A minimum 20 amp service must be provided.**

2.3.2. Before plugging the air dryer into the electrical outlet, make sure the main power switch is in the OFF position.

2.3.3. Plug the air dryer into the proper electrical supply.

### 2.4. Start-Up

2.4.1. A plastic plug with a small hole (orifice plug) is located in the LOW PRESSURE OUTLET port at the rear of the air dryer. This plug will permit the unit to operate in a simulated "on line" condition.

2.4.2. Place the main power switch to the ON position.

A. The LOGIC SCAN LED will start flashing.

B. The AIR COMPRESSOR, HEATLESS DRYER, and VENTILATING FAN will start and air will flow through the orifice in the LOW PRESSURE OUTLET.

C. Toggle the RESET SWITCH to clear erroneous alarms.

D. P-LO (Pressure Low) will appear on the ALARM DISPLAY until the OUTLET PRESSURE GAUGE reads approximately 8 PSIG or more. During the time P-LO appears on the display, the ALARM LED will also be energized.

E. -HC- (Humidity Condition) may appear on the ALARM DISPLAY. If -HC- does not clear within approximately two minutes, -HA- will appear in the ALARM DISPLAY and the AIR COMPRESSOR will shut down. If this happens, simply toggle the RESET SWITCH. This will allow the unit to run for approximately two more minutes. The -HC- should clear within 10 - 15 minutes.

F. The five humidity level LED's will energize when the desiccant in the HEATLESS DRYER is dry. If, during initial start-up, -HC- appears in the ALARM DISPLAY, one or more LED's will be off. The LED's will energize as the desiccant dries out. This should take less than 15 minutes.



- G. The OUTLET PRESSURE GAUGE will stabilize at approximately 10 PSIG.
- H. The air pressure in the AIR STORAGE TANK will cycle between 20 and 50  $\pm 2$  PSIG as noted on the TANK PRESSURE GAUGE.
- I. The red ALARM LED will be energized only when the P-LO, P-HI, -CP- or -HA- appears in the ALARM DISPLAY. The ALARM LED will be off in all other cases. (The alarm LED is located above the alarm display.)
- J. Check for pressure leaks that may have occurred during shipment.

**Caution: Avoid contact with electrical circuits.**

### SECTION 3

#### TEST ROUTINE

With the air dryer in operation, perform the following test:

##### 3.1. Low Pressure Alarm Test

- 3.1.1. Lower the front instrument panel.
- 3.1.2. Locate the outlet PRESSURE REGULATOR and loosen the lock nut on the handle.
- 3.1.3. Rotate the knob counterclockwise and reduce the pressure on the OUTLET PRESSURE GAUGE until alarm occurs.
- 3.1.4. At this point, P-LO will appear in the ALARM DISPLAY. Turn the handle clockwise and increase the pressure on the OUTLET PRESSURE GAUGE to 10 PSIG. P-LO will disappear from the ALARM DISPLAY.

##### 3.2. High Pressure Alarm Test

- 3.2.1. Rotate the knob on the PRESSURE REGULATOR clockwise until the OUTLET PRESSURE GAUGE reads approximately 15 PSIG. P-HI will now appear in the ALARM display.
- 3.2.2. Reduce the pressure to 10 PSIG. P-HI will disappear.

### 3.3. Humidity Condition Test

Locate the HUMIDITY TIME DELAY switch on the logic printed circuit board.

- 3.3.1. Place the #1 switch in the ON position (CLOSED), and switches 2-8 in the OFF position (OPEN). This represents approximately a one-minute time delay before a humidity alarm occurs.

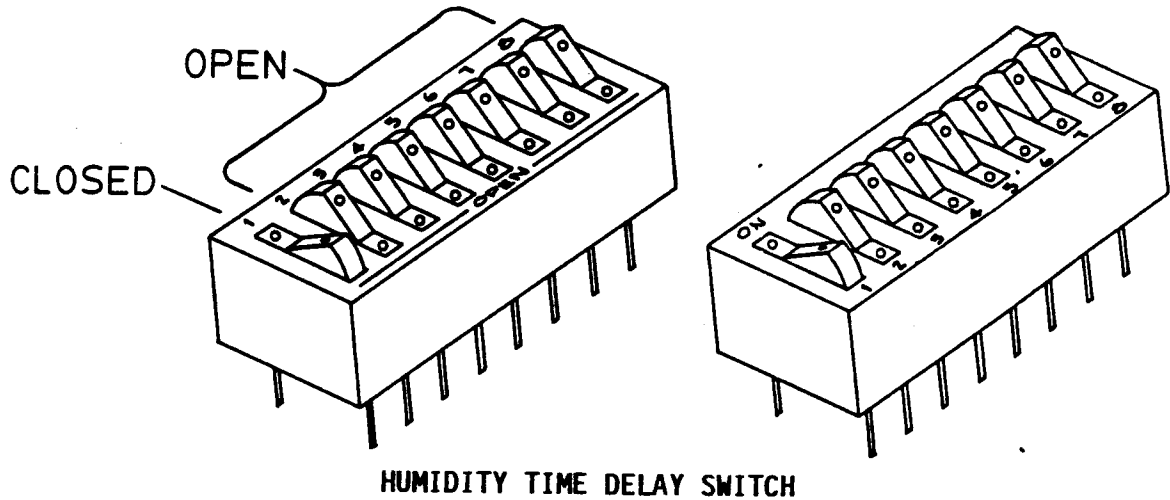

Figure 3.

**Note:** Only one switch should be in the CLOSED position at any time. Figure 3 shows the #1 switch in the CLOSED position.

- 3.3.2. Locate the HUMIDITY TEST SWITCH on the front of the instrument panel. With the AIR COMPRESSOR running, toggle and hold the HUMIDITY TEST SWITCH down. Notice the five humidity LED's. These LED's should begin to de-energize. -HC- will appear in the ALARM DISPLAY and the HUMIDITY BYPASS SOLENOID will discharge the air in the AIR STORAGE TANK to the atmosphere.

**Note:** The ALARM LED will not energize during an -HC- (humidity condition).

**Note:** The air compressor must be running during this test.

- 3.3.3. The above test confirms the proper operation of the following humidity system components:
- A. Humi-alarm Circuit Board
  - B. Humidity Bypass Solenoid
  - C. LED Humidity Display
  - D. Humidity Sensing Element
  - E. Associated Wiring

### 3.4. Humidity Alarm Test

- 3.4.1. A humidity alarm will result after the system has remained in a Humidity Condition (-HC-) for longer than the time set on the HUMIDITY TIME DELAY SWITCH. (Example, refer to Figure 3 , Page 5.)
- 3.4.2. To perform this test, simply keep the dryer in a humidity condition (-HC-) longer than one minute. This can be accomplished by holding the HUMIDITY TEST SWITCH in the DOWN position.
- 3.4.3. After the dryer has been in a Humidity Condition (-HC-) longer than one minute, the following sequence will occur:
  - A. -HA- Humidity Alarm will appear in the ALARM DISPLAY.
  - B. The ALARM LED will be on while -HA- appears in the display.
  - C. The AIR COMPRESSOR will shut down.
  - D. The two green LED's on the humidity indicator (and possibly some or all red LED's) will be off.
- 3.4.4. Release the HUMIDITY TEST SWITCH and toggle the ALARM-RESET SWITCH. The following sequence should occur:
  - A. The AIR COMPRESSOR will start running.
  - B. The five HUMIDITY LED's will begin to energize.
  - C. When the green HUMIDITY LED's have energized, the HUMIDITY BYPASS SOLENOID will close and -HC- will disappear from the ALARM DISPLAY.

### 3.5. Compressor Performance Test

- 3.5.1. A -CP- (Compressor Performance) alarm will appear on the alarm display when the air compressor remains in an operating condition longer than the desired selectable length of time.

**Example:** If the normal flow of air is approximately 1200 SCFD (as read on the FLOW BLOCK) and the time between the AIR COMPRESSOR starting and stopping (the 20 to 50 PSIG pressure cycle) is 1½ minutes, then the normal running time is 1½ minutes.

- 3.5.2. Now, with the normal cycle at 1½ minutes, the COMPRESSOR PERFORMANCE TIME DELAY SWITCH (located on the logic printed circuit board) should be set with the #2 switch in the closed position (ON), and all other switches in the OPEN position (OFF).

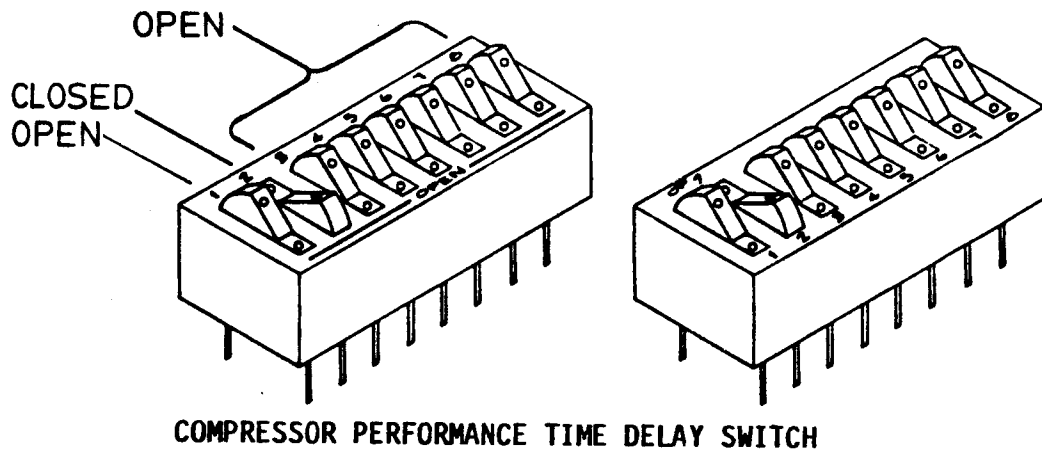

Figure 4.

**Note** Only one switch should be in the CLOSED position at any time. Figure 4 shows the #2 switch in the CLOSED position.

- 3.5.3. With the above conditions set, a -CP- will appear on the alarm display if, for any reason, the air compressor runs continuously for a period exceeding (2) two minutes.

**Note:** The COMPRESSOR PERFORMANCE TIME DELAY is factory set at two minutes.

The following items represent some possible reasons a -CP- alarm would be displayed:

- A. An increase in flow to pipes or cables.
- B. A leak in the internal pneumatic connections in the air dryer.
- C. An air compressor requiring routine maintenance.
- D. A faulty solenoid valve in the heatless dryer.

Refer to troubleshooting guide for further details.

- 3.5.4. To test -CP- alarm, simply create a temporary leak in the dryer which will force the AIR COMPRESSOR to run longer than two minutes. After approximately two minutes, -CP- will appear on the ALARM DISPLAY.
- 3.5.5. Terminate the temporary leak and clear the -CP- alarm from the ALARM DISPLAY by toggling the RESET SWITCH.

**Note:** Steps 3.1. through 3.5.5. must be completed before proceeding to Step 4.1.

## SECTION 4

### DEMONSTRATION OPERATION

- 4.1. This unit has successfully completed a five-day operational test at the factory. Each component was individually calibrated and tested over its full range of operation. The following list represents the existing "settings" of each component.
- 4.1.1. The air compressor ON/OFF PRESSURE SWITCH will permit the AIR COMPRESSOR and HEATLESS DRYER to cycle from 20 PSIG to 50 PSIG  $\pm 2$  PSIG. (Figure 12, Page 20)
- 4.1.2. The LOW PRESSURE ALARM SWITCH will cause a "P-LO" alarm to be displayed if the outlet pressure drops below 7 PSIG on the OUTLET PRESSURE GAUGE.
- 4.1.3. The HIGH PRESSURE ALARM SWITCH will cause a "P-HI" alarm to be displayed if the outlet pressure exceeds 12 PSIG on the OUTLET PRESSURE GAUGE.

The following refer to Figure 31 and Figure 32.

- 4.1.4. The HUMIDITY METER is represented by the five LED's (three red and two green), located just below the ALARM DISPLAY. When all LED's are on, the humidity level is below 2% RH.
- 4.1.5. During shipment, the desiccant in the HEATLESS DRYER towers may have adsorbed some moisture. If this is the case, one or more LED's may be off during initial start-up; however, they will come on as the desiccant "dries out" during operation. All LED's on the HUMIDITY METER should be energized after 15 minutes of operation.
- 4.1.6. The LOGIC SCAN LED will pulse on and off whenever the dryer is turned on. This indicates the digital circuitry is functioning properly.
- 4.1.7. The ALARM LED is normally off. It will only energize when an alarm condition is present on the digital ALARM DISPLAY.

**Example:** The ALARM LED will energize during the following alarm conditions: P-LO, P-HI, -CP- and -HA-. The ALARM LED will not energize when -HC- is displayed or when the digital ALARM DISPLAY is blank.

## SECTION 5

### ALARM SUMMARY

- 5.1. The following alarms and conditions will be displayed on the digital ALARM DISPLAY.

**Note:** These alarm set points are field adjustable.

- 5.1.1. P-HI represents an alarm which results when the outlet pressure (as read on the OUTLET PRESSURE GAUGE) exceeds the set point of the HIGH PRESSURE SWITCH. (Reference Figure 13 )

This switch is factory set to alarm when the outlet pressure exceeds 12 PSIG.

Refer to page 20, Figure 13, for adjustment procedure.

- 5.1.2. P-LO represents an alarm which results when the OUTLET PRESSURE GAUGE drops below the set point of the LOW PRESSURE SWITCH. The switch is field adjustable; however, it is factory set to alarm when the outlet pressure drops below 7 PSIG.

Refer to Page 20, Figure 13, for adjustment procedure.

- 5.1.3. -CP- represents an alarm which occurs when the AIR COMPRESSOR and HEATLESS DRYER run time (between 20 PSIG and 50 PSIG) exceeds the set point of the solid state compressor performance time delay switch. This switch is factory set at approximately two minutes.

Refer to Page 7, Figure 4, for adjustment procedure.

- 5.1.4. -HC- represents a humidity condition only. When a HUMIDITY CONDITION is detected, the -HC- alarm will appear on the alarm display. Additionally the SSR board will de-energize the bypass solenoid valve, which bypasses the wet air into the atmosphere.

- 5.1.5. -HA- Humidity Alarm. If the -HC- alarm exceeds the set time delay, the -HA- alarm will appear on the alarm display. This alarm will turn off the air compressor, indicating a HUMIDITY CONDITION is still present and requires IMMEDIATE ATTENTION.

## SECTION 6

### PRINCIPLES OF OPERATION

#### 6.1. Air System

The air flow is shown schematically in Figure 6 . The various steps involved are summarized as follows:

#### 6.2. Air Compressor (Item 1)

Ambient air is drawn through the INTAKE FILTERS on the AIR COMPRESSOR and compressed to approximately 50 PSIG. It then passes to the PRE-COOLER (Item 2) where hot compressed air is cooled before entering the HEATLESS DRYER.

#### 6.3. Puregas Heatless Dryer (Dehydrator) (Item 3)

The Puregas HEATLESS DRYER, which is located downstream from the AIR COMPRESSOR, consists of two desiccant-filled towers, a manifold, a timer and two solenoid valves. It is arranged and cycled so as one tower delivers dry air to the cable system, the desiccant in the other tower is purged or dried by a small quantity of the dry air supplied by the first tower. (Figure 5 ) The tower functions reverse at 30-second intervals. The towers operate as follows:

##### A. Tower No. 1

Air from the COMPRESSOR enters the solenoid valve which is controlled by an electrical timer and is forced upward through the desiccant in the tower. Moisture is adsorbed by the desiccant. The dried air then flows down through an air tube in the center of the desiccant tower, out an open ball check valve and is finally delivered through the CAPACITY CONTROL VALVE to the AIR STORAGE TANK.

B. Tower No. 2

Simultaneously with the operation of Tower 1, as described above, the solenoid valve of Tower 2 is opened to the atmosphere. The main dry air supply from Tower 1 is prevented from entering Tower 2 by automatic closure of the ball check valve. However, a small quantity of the dry air is forced through an orifice into the air tube, then down through the desiccant bed and finally expelled to the atmosphere through the solenoid valve. As the dry air passes over the desiccant bed, it adsorbs up the moisture previously collected while Tower 2 was furnishing dry air (as Tower 1 is doing at this time) and this moisture is expelled with the air. The desiccant in Tower 2 is thus dried and made ready for the cycle reversal.

Tower No. 2 and Tower No. 1 reverse their functions; Tower 2 takes over the air drying operation while the desiccant in Tower 1 is being dried.

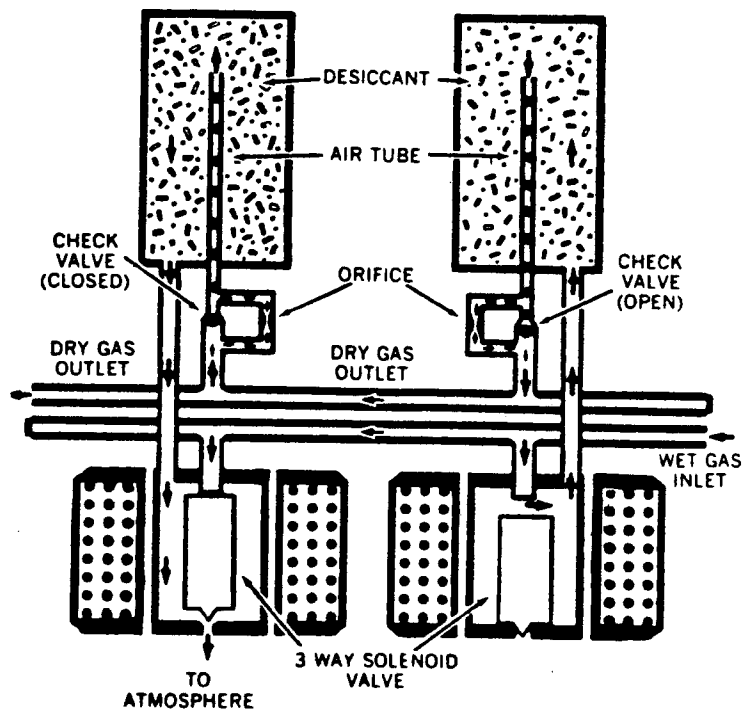

PUREGAS HEATLESS THEORY

Figure 5.



**6.4. Capacity Control Valve (Item 4)**

The CAPACITY CONTROL VALVE has two functions:

1. Maintains proper purge pressure through the heatless dryer which will insure dry air delivery under maximum flow conditions.
2. Acts as a check valve which prevents air in the AIR STORAGE TANK from bleeding back through the HEATLESS DRYER when the AIR COMPRESSOR is not operating.

**6.5. Pressure Switch and Storage Tank (Items 7 and 5)**

Once the air passes through the CAPACITY CONTROL VALVE, it is channeled to the AIR STORAGE TANK and builds up to 50 PSIG. The pressure switch will then signal the compressor to shut down. The AIR COMPRESSOR will remain off until the tank pressure drops below 20 PSIG. Now the ON/OFF PRESSURE SWITCH will start the AIR COMPRESSOR and the cycle continues. The tank pressure gauge (Item 6) indicates actual AIR STORAGE TANK pressure.

**6.6. Pressure Regulator (Item 8)**

From the AIR STORAGE TANK, the air is channeled to the HIGH PRESSURE OUTLET VALVE and the LOW PRESSURE OUTLET which is regulated by the PRESSURE REGULATOR (Item 8), (0-30 PSIG).

**6.7. Humidity Sensing Tube (Item 10)**

Air is then channeled to the HUMIDITY SENSING TUBE and flows over the HUMIDITY SENSOR. The HUMIDITY SENSOR (not shown) will signal the alarm systems if the relative humidity rises above 10%.

**Note:** To test the humidity systems, wet air from the PRECOOLER can be channeled directly to the HUMIDITY SENSING TUBE (Item 10) by using the HUMIDITY TEST VALVE. A CHECK VALVE (Item 16) is provided to prevent air bleeding back.

**6.8. Humidity Bypass Solenoid Valve (Item 11)**

The air now flows through the HUMIDITY BYPASS VALVE. The HUMIDITY BYPASS VALVE allows dry air to pass into the cable or dump wet air into the atmosphere. The bypass valve gets its electrical signal from the HUMIDITY ALARM CIRCUIT.

**Note:** When energized, the humidity bypass valve directs dry air to the cable. When de-energized, the valve bypasses air to the atmosphere.

6.9. High-Low Pressure Switch (Item 12)

Dry air will now flow to the HIGH-LOW PRESSURE SWITCH which triggers an alarm if the pressure drops below or rises above a preset value. For adjustments of the pressure switch, refer to Section

6.10. Flowmeter and Low Pressure Outlet (Item 13)

Finally, the dry air flows through the FLOWMETER and into the air outlet. The FLOWMETER indicates how much air flow is being used by the cables.

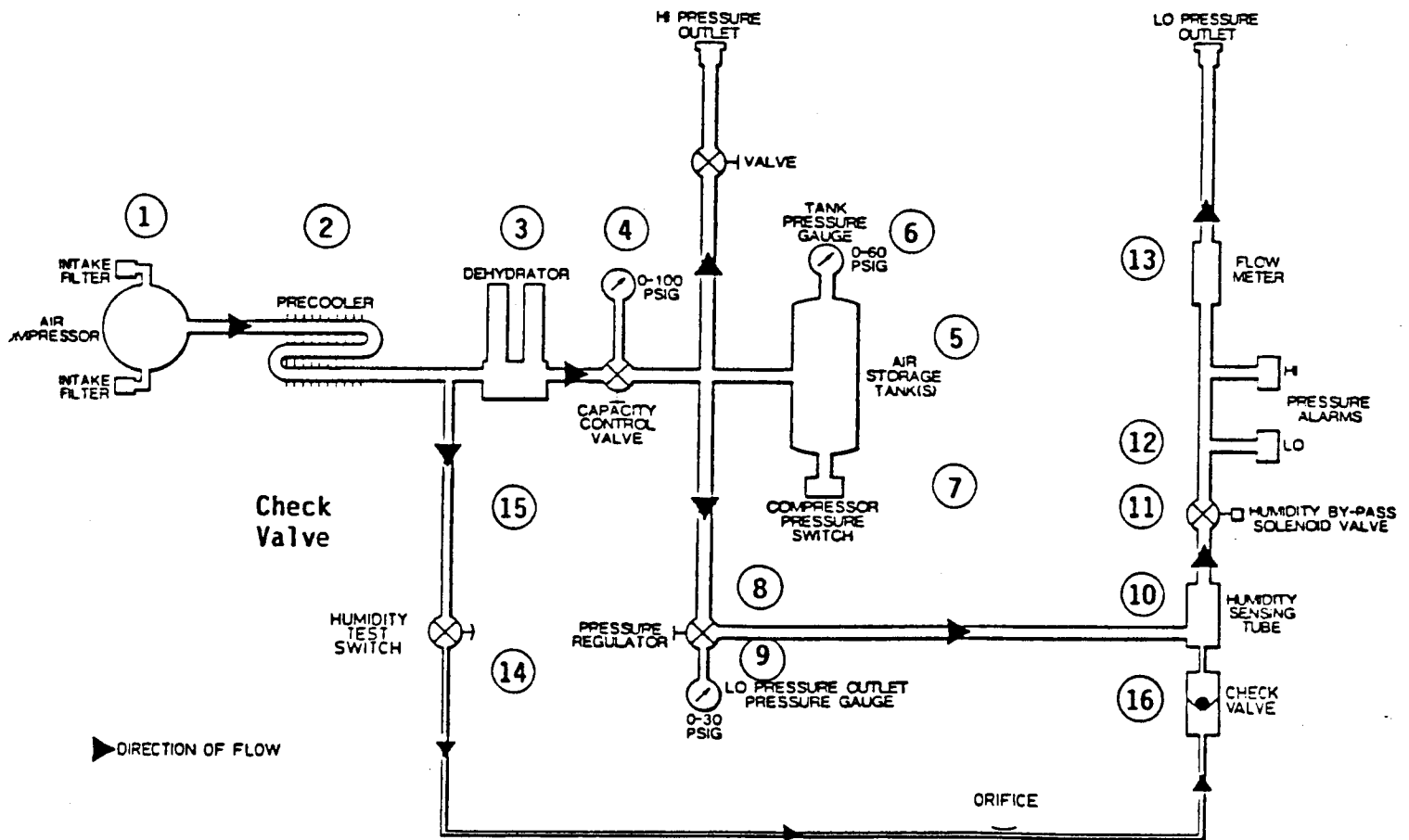

FLOW DIAGRAM

Figure 6.

SECTION 7

7.1. Solid State Circuitry:

**LOGIC BOARD - P-05847**  
(Refer to Page 33 , Figure 21 ).

The logic board performs two (2) major functions. The first is controlling the SSR board which turns the compressor motor, heatless dryer and the bypass solenoid valve on and off. The second function is to monitor all alarms in the system and send the alarm(s) to the display board. The CP (compressor performance) and HA (humidity alarm) alarms have a selectable time delay, therefore disallowing nuisance alarms from appearing on the alarm display.

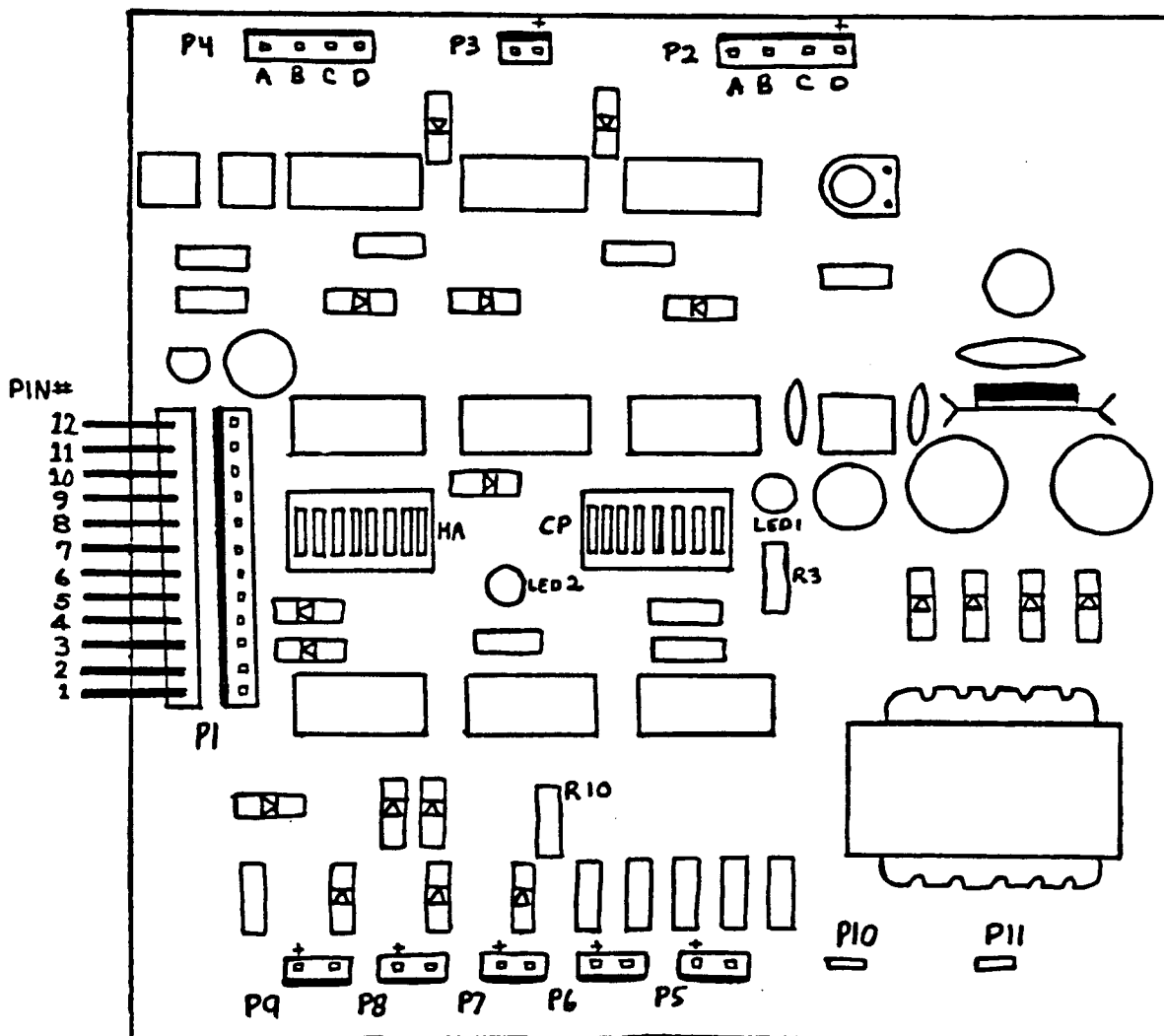

Logic Board  
Figure 7

7.2. Display Board - P-05627 (located beneath the logic board).  
The display board monitors alarm signals received from the logic board. It does this by scanning through the alarms sensor one by one and displaying any active alarm(s).

7.3.

### HUMIDISTAT BOARD P-05521

AND

### VISUAL DISPLAY BOARD P-05627

The Humidity Board has a remote visual display consisting of five (5) L.E.D.'s (two green, three red) which are located below the digital display on the front panel.

During normal "DRY AIR" conditions, all L.E.D.'s will be lit. If the relative humidity increases above 2%, the "2%" indicator will go out. If the relative humidity increases above 10% (which is the alarm point), the second green L.E.D. will go out. As the percentage of relative humidity continues to increase, the red L.E.D.'s will go out and an HC (humidity condition) alarm will appear at the display.

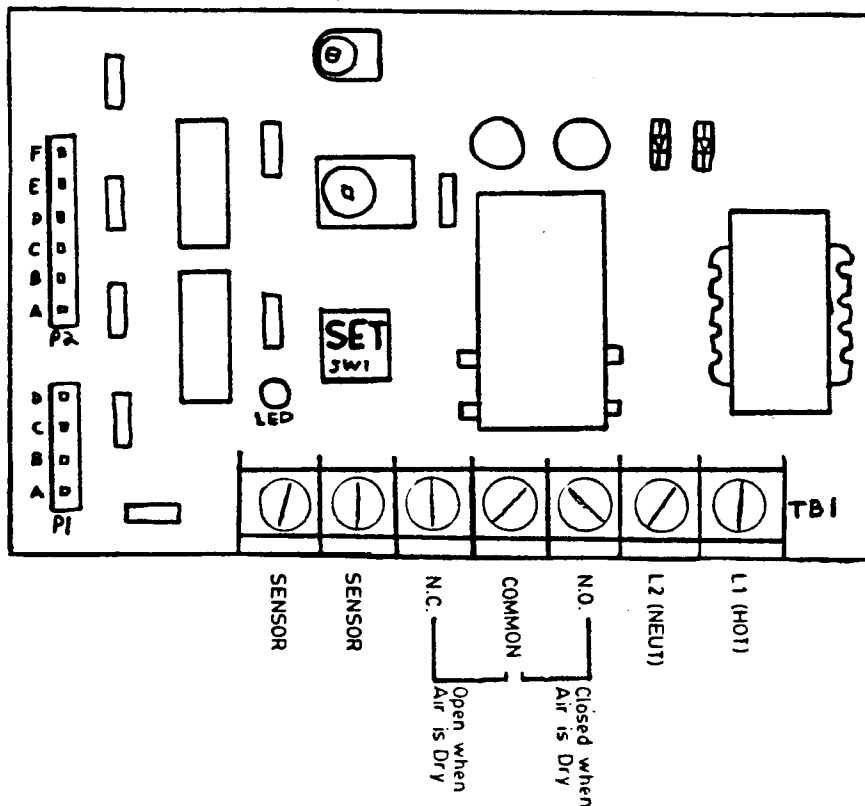

Humidistat Board

Figure 8

7.4.

SOLID STATE RELAY BOARD ASSEMBLY (SSR)

P-05846 (TOP) P-06101 (BOTTOM)

The SSR Board function is to turn on the compressor motor, the heatless dryer, and energize the bypass solenoid valve at the command of the logic board. The SSR board uses solid state circuitry, thus eliminating the need for mechanical contactors.

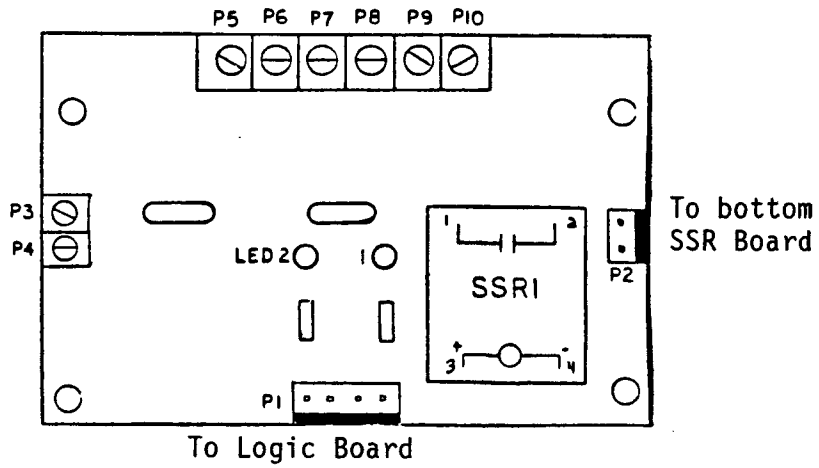

Top SSR Board

Figure 9

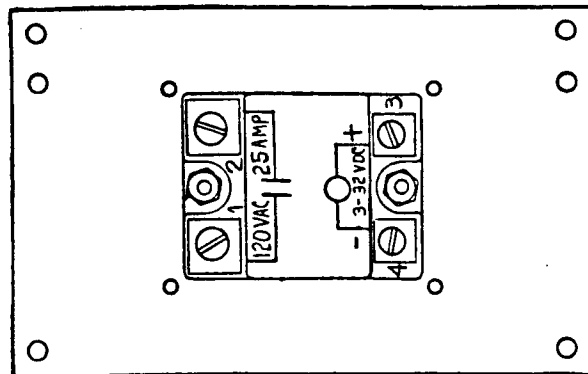

Bottom SSR Board

Figure 10

\*EXCEPT AS MAY BE OTHERWISE PROVIDED BY CONTRACT, THESE DRAWINGS AND SPECIFICATIONS ARE THE PROPERTY OF GENERAL CABLE CO. ARE ISSUED IN STRICT CONFIDENCE AND SHALL NOT BE REPRODUCED OR COPIED, OR USED AS THE BASIS FOR THE MANUFACTURE OR SALE OF APPARATUS WITHOUT PERMISSION.

REVISIONS		DWG. NO.	P-05691	
REV	DESCRIPTION	BY	DATE	ECO
	NEW RELEASE	JW	2-8-84	6789

REVISIONS CONTINUED IN TOP LEFT CORNER

REV	DESCRIPTION	BY	DATE	ECO
A	WN 12 WAS FROM HUM BRD NEUT TO VENT SOLENOID, WN 13 WAS FROM VENT SOLENOID TO HHS DRYER, WN 26 WAS BLUE/RED, WN 27 WAS WHITE/VIOLET, WN 28 WAS RED/WHITE, WN 29 WAS WHITE/GREEN, WN 30 WAS RED/BLACK, WN 31 WAS WHITE/ORANGE, WN 34 WAS GREEN/BLACK, WN 35 WAS ORANGE/RED, JUMPER WAS RED, ADDED WN DESIGNATIONS FOR 26 THRU 39	JW	6-1-84	6868
B	WN 26, 27, 28, 29, 30 & 31 WERE BLACK, NOTE 1 WAS "ALL INTER-CONNECTING WIRING PROVIDED..."	CM	7-23-84	
C	ADDED HUMIDITY TUBE AND WN 40 & WN 41	CM	4-8-85	7643
D	ADDED WNS 42-45, REVISED TO SHOW FC BOARD UPDATES.	CM	6-20-85	8294
E	WN 11, 12, 14, 19, 38, 39 REROUTED, WN 15, 16, 20, 21 (AT COMPRESSOR) DELETED, ADDED WN 12A, 12B, 19A, 19B (AT COMPRESSOR), ADDED TERMINAL BLOCK (TB-2)	CM	9-18-85	8294
F	PICTORIALLY REVISED TO REFLECT VENDOR CHANGE	CM	1-17-86	8554
G	ADD NOTE 4	JW	6-1-87	9998
H	DELETED COLOR DESIGNATIONS	CM	2-24-89	12701
I	DELETED NOTE 1	DF	03-17-89	13104

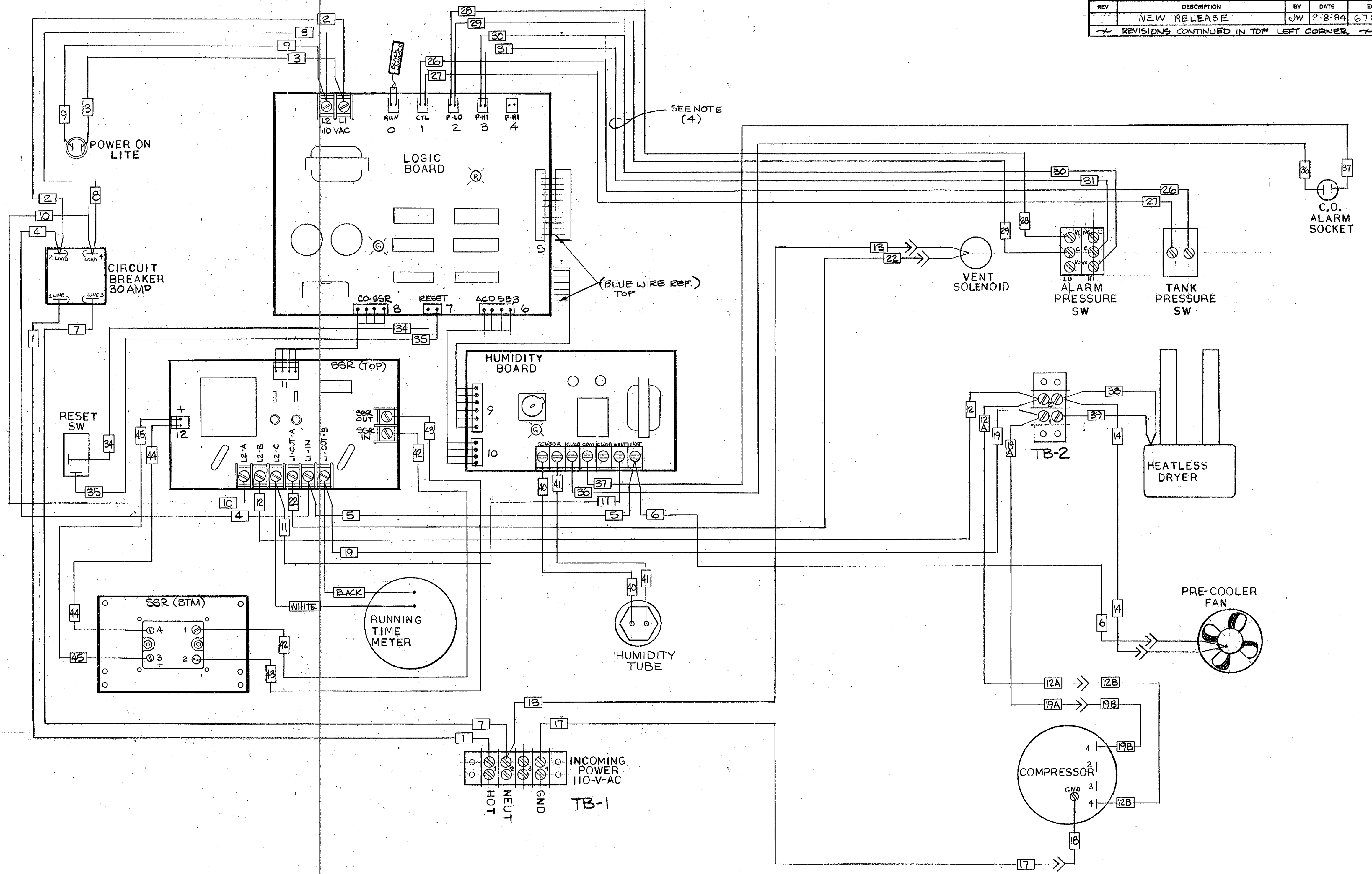

NOTES

- 1.
- 2.
3. SYMBOLS → P-5-142 QUICK DISCONNECT
4. WN 30 & 31 NOT USED ON P-3100-D-PNWB.

QTY.	PART NO.	DESCRIPTION	WT.	ITEM NO.
MATERIAL		FINISH	PUREGAS	
DIMENSIONAL TOLERANCES UNLESS OTHERWISE SPECIFIED DIMENSIONS ARE IN INCHES		TITLE WIRING DIAGRAM 3100/4200 D.C.O		
TOLERANCE ON DECIMALS ± 0.06		DRAWN JERRY WILLIAMS DATE 2-8-84		
TOLERANCE ON ANGLES ± 0°30'		CHECKED DATE		
TOLERANCE ON HOLE ± 0.018		APPROVED DATE		
SCALE	NO. REQ'D	D P-05691 H		
HEAT TREAT		SIZE SHFT OF REV		

BRUNING 44-131 51257-1

## SECTION 8

### GENERAL MAINTENANCE

- 8.0. The following paragraphs indicate some maintenance procedures but will by no means cover all possible maintenance problems. If the problems persist after thoroughly consulting this guide, contact General Cable Company, Apparatus Division, Puregas Technical Service Department at (303) 427-3700.

#### Caution

**When working around energized circuits, extreme caution should be taken to prevent injury to personnel and damage to equipment.**

It is very important that routine maintenance be performed at six-month, one-year and two-year intervals.

#### 6 Months

- . Flow Rate - compare to previous flow rate
- . Humidity Alarm Check - Page 6
- . Safety Valve - Page 19
- . Pressure Switch - Page 19
- . High Low Pressure Alarm - Page 20
- . Compressor Performance Alarm - Page 6
- . Capacity Control Valve - Page 21
- . Filters (Air Inlet/Cabinet) - Figure 19

#### 1 Year - 4000 Hours

- . Install the compressor maintenance kit (P-07584) Refer to Page 21 for parts list.
- . Repeat 6-Month Check.

2 Years - 8000 Hours

- . Install Heatless Dryer Maintenance Kit (P-200-499). Refer to Figure 16, Page 26, for parts breakdown.
- . Repeat 6-months Check
- . Repeat 1 year Check

**Note:** Compressors require maintenance kit installation every 4000 hours. Puregas Division recommends a historical record be maintained on all air dryers.

**8.1. Air Compressor Safety Valve (Figure 15, Item 4)**

The air compressor safety valve is factory preset to prevent the AIR COMPRESSOR from delivering air at over 55 PSIG. The SAFETY VALVE can be adjusted as follows:

- A. With the AIR COMPRESSOR running, pull up the valve lock collar of the CAPACITY CONTROL VALVE and turn the knob clockwise until 56 to 60 PSIG is read on the CAPACITY CONTROL VALVE GAUGE.
- B. Referring to Figure 15, loosen the safety valve lock nut (Item 9) and adjust the screw (Item 10) until the maintained pressure is 55 PSIG and the relief valve is releasing air.
- C. Tighten the lock nut (Item 9) of the relief valve.
- D. Turn the CAPACITY CONTROL VALVE knob counterclockwise until 48 to 50 PSIG is read on the CAPACITY CONTROL VALVE GAUGE. Press the valve lock collar down into the locked position.
- E. Allow the compressor to cycle through the cycling pressure range several times and check to be sure the AIR COMPRESSOR SAFETY VALVE has seated properly and is not leaking.

**8.2. Air Compressor Pressure Switch (Figure 12)**

The ON/OFF PRESSURE SWITCH is factory set to stop and start the AIR COMPRESSOR and maintain the pressure in the AIR STORAGE TANK.

The pressure in the AIR STORAGE TANK should cycle between 20 PSIG and 50 PSIG  $\pm 2$  PSIG as noted on the HIGH PRESSURE GAUGE (Tank Pressure). To adjust the ON/OFF PRESSURE SWITCH, refer to Figure 12.



ADJUST IN PROPER SEQUENCE

**STEP NO. 1**

RANGE ADJUST

TURN DOWN FOR HIGHER  
CUT-IN PRESSURE, OR  
UP FOR LOWER CUT-IN

**STEP NO. 2**

DIFFERENTIAL ADJUST

TURN DOWN FOR HIGHER  
CUT-OUT, OR UP FOR  
LOWER CUT-OUT

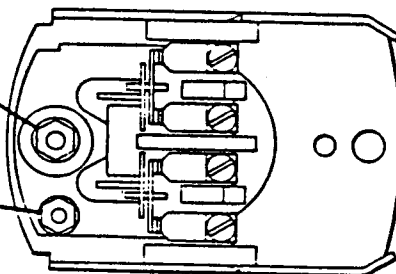

Note: OXIDATION INHIBITOR P-07510  
Should the contacts start to oxidize, apply small  
amount of the Oxidation Inhibitor to each surface.

**AIR COMPRESSOR PRESSURE SWITCH**

**Figure 12**

**8.3. High-Low Pressure Alarm (Figure 13)**

High and Low pressure switch alarms are connected to the output  
air line. These switches are factory set at 7.0 PSIG to actuate  
on falling pressure for the low pressure alarm and at 12 PSIG  
to actuate on increasing pressure for the high pressure alarm.  
To adjust the pressure alarms, refer to Figure 13. The pressure  
setting for adjustment of these switches may be made with  
use of the PRESSURE REGULATOR.

**Step No. 1 - High Adjust**

Turn main adjustment screw  
counterclockwise (OUT) to  
lower or clockwise (IN) to  
raise.

**Step No. 2 - Low Adjust**

Turn "Low Set" switch  
screw counterclockwise  
(IN) to lower or clockwise (OUT) to raise.

**Step No. 3**

Recheck both settings.

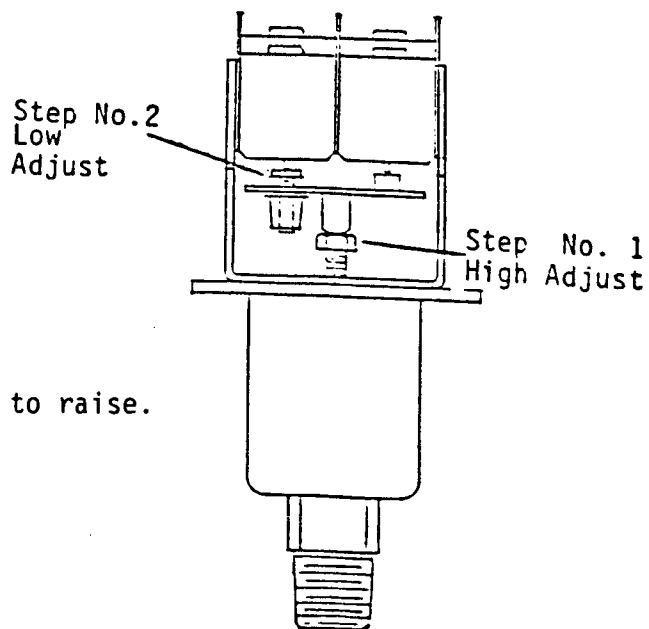

High-Low Pressure Switch (Old Style)  
**FIGURE 13**

8.3. High-Low Pressure Alarm (Continued)  
(New Style) P-05648  
FIGURE 13A

The new style pressure switch consists of two separate snap action switches, each with an independently adjustable set point. The alarm set points have been factory set to operate at approximately 12.0 + 1.5 PSIG for the high pressure alarm and 6.5 + 1.5 PSIG for the low pressure alarm. To adjust the high-low pressure alarm, turn the adjustment screw (clockwise) to raise the set point and (counterclockwise) to lower the set point.

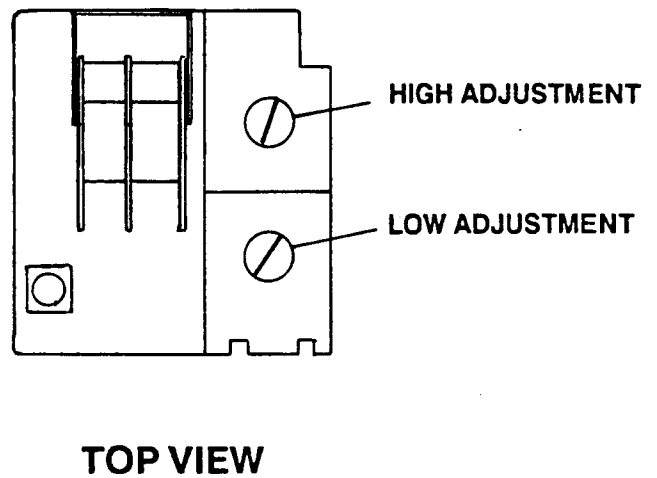
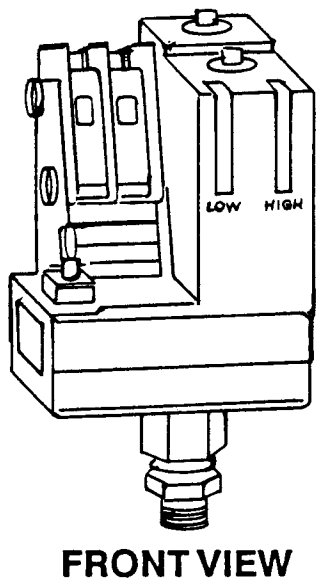

HIGH-LOW PRESSURE SWITCH (NEW STYLE)

FIGURE 13A

#### 8.4. Capacity Control Valve

The CAPACITY CONTROL VALVE maintains proper purge pressure through the HEATLESS DRYER which will insure dry air delivery under maximum flow conditions. it also acts as a check valve to prevent air in the AIR STORAGE TANK from bleeding back through the HEATLESS DRYER when the AIR COMPRESSOR is not operating.

- A. Make sure the AIR COMPRESSOR is running at the time of adjustment.
- B. Pull up on the valve lock collar and adjust the valve handle clockwise until 48 to 50 PSIG is read on the CAPACITY CONTROL GAUGE which is mounted on the HEATLESS DRYER manifold, then press locking collar back in place.

#### 8.5. Air Compressor Maintenance (Figure 15)

The P-07584 maintenance kit is designed to provide the parts necessary for one year's maintenance on Models P-3100DCO/P-4200DCO Air Dryers that are operating at normal capacity. The contents of the maintenance kit are as follows:

<u>Part. No.</u>	<u>Description</u>	<u>Quantity</u>
P-3861	Piston Seal	4
P-3862	Piston Ring	4
P-3864	Manifold Sleeve	2
P-3866	Head Gasket	2
P-3867	Outlet Valve	2
P-3868	Inlet Valve	2
P-3869	Cylinder Gasket	2
P-3870	Valve Plate	2
P-3981	Rider Ring	2
P-3986	Filter Element	4
P-5000-6-47D	Sensing Element	1

If the AIR COMPRESSOR shows evidence of overheating or excessive noise, stop immediately for repairs.

Regular inspection may prevent expensive repairs. The rider ring (Figure 15, Item 25) thickness can be an indication of the need for AIR COMPRESSOR maintenance. If a rider ring measures .055 inches or less in thickness, the maintenance kit P-07584 should be installed. The thickness of a new rider ring is .060 inches.

8.5.1. The air compressor is oilless and requires no lubrication. It is recommended the piston rings, piston seals, rider rings, inlet valves, outlet valves, valve plates and gaskets be replaced at 4000 hours of run time.

**Note:** At higher ambient temperatures, maintenance must be performed more frequently.

REASON	COMPLAINT			
	LOW PRESSURE	OVERHEATING OR EXCESSIVE AMP DRAW	EXCESSIVE NOISE	WON'T START UNDER LOAD
WORN PISTON RINGS	●			
WORN RIDER RINGS	●		PISTON HITTING CYLINDER	
DIRTY VALVES	●			
BENT VALVES	●			
BLOWN HEAD GASKET	●		AIR BLOWING OUT INTAKE FILTER	
DIRTY FILTERS	●			
LOW VOLTAGE		●		●
CYLINDER MISADJUSTMENT		PISTON HITTING INTAKE VALVE	PISTON HITTING INTAKE VALVE	●
LEAKY CONNECTIONS	●			
RELIEF VALVE SET TOO HIGH		●		
RELIEF VALVE SET TOO LOW	●			
WRONG VOLTAGE HOOK UP		●	●	●
DIRT OR LIQUID IN TOP OF PISTON	●	●	●	●

**AIR COMPRESSOR TROUBLESHOOTING GUIDE**  
Figure 14

A. Disassembly

- (1) Remove the four screws which secure the AIR COMPRESSOR shroud and pull shroud forward and off. Remove the four cylinder head bolts and lift off the cylinder head and valve components.
- (2) Remove manifold assembly.
- (3) Remove the two cylinder bolts and two lock washers and lift off the cylinder.
- (4) Remove the piston seals, piston rings and rider rings.

**Note:** Clean all components with a nonflammable, nontoxic cleaning solvent. **DO NOT FLOOD THE PISTON WRIST PIN OR CONNECTING ROD MAIN BEARING WITH SOLVENT OR THE PERMANENT LUBRICANT WILL BE WASHED AWAY.**

- (5) The head gaskets may have become firmly attached to the flat surfaces of cylinder heads or cylinders. remove the old gasket material. Use No. 240 grit emery cloth (or wet/dry abrasive material) to flat-sand the cylinder surfaces. Follow with No. 400 grit emery cloth (or wet/dry) to dress these flat surfaces before reassembly with new gaskets.

#### B. Assembly

- (1) Install the new piston seals, piston rings and rider rings on the piston. Locate the ring joints approximately opposite each other.
- (2) Attach cylinders to bracket with the cylinder bolts and lock washers. Tighten bolts (finger tight). Move the piston to the top dead center position and adjust the cylinder flush with the top of the piston and tighten the cylinder bolts.
- (3) Install the valve components, gaskets and valve plates by stacking them as outlined in Figure 15, exploded view of air compressor. The leaves on the intake and discharge valves have been pre-bent and should not be adjusted in any way.
- (4) Install the head assembly using the lock washers and head bolts. Do not tighten the head bolts at this time.

#### CAUTION

**ON THE TOP OF EACH CYLINDER HEAD, THE ENDS OF TWO FINS HAVE BEEN OMITTED. THEY ARE ALWAYS IN THE EXHAUST PORT.**

- (5) Install manifold nuts and seals on the manifold and assemble to the elbow fitting on the head assembly. **DO NOT TIGHTEN.**
- (6) Install the second head assembly and assemble the manifold. Tighten all head bolts and manifold nuts.
- (7) Soap test all fittings.

Note: Tighten head bolts 150-160 inch lbs. A small leak around the head is okay.

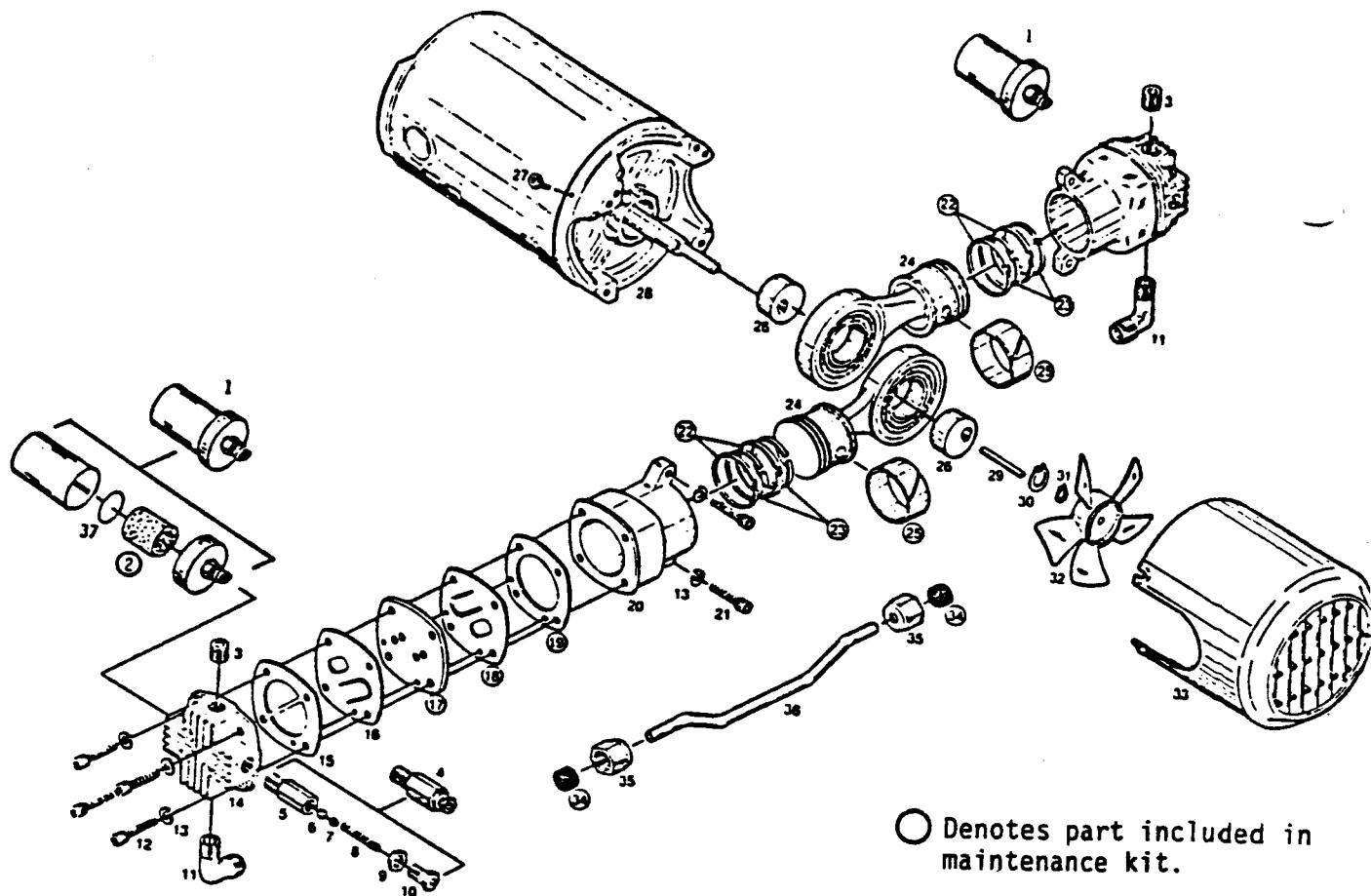

EXPLODED VIEW OF AIR COMPRESSOR AND MOTOR ASSEMBLY

FIGURE 15

Ref. No.	Description	Puregas No.	Ref. No.	Description	Puregas No.
1	Air Intake Filter Assy. 2/unit	P-02619	20	Cylinder 2/unit	P-3874
②	Felt	P-3986	21	Cylinder Screw 4/unit	Deleted
3	Pipe Plug 2/unit	P-3998	②②	Piston Ring 4/unit	P-3862
4	Safety Valve	P-3996	②③	Piston Seal 4/unit	P-3861
5	Not Supplied		24	Piston Rod Assy. 2/unit	P-3872
6	Not Supplied		②⑤	Rider Ring 2/unit	P-3981
7	Not Supplied		26	Eccentric 2/unit	
8	Not Supplied			Model 4200 DCO	P-01238
9	Not Supplied			Model 3100 DCO	P-02645
10	Not Supplied		27	Screw 4/unit	P-4033
11	Manifold Elbow 2/unit	P-4024	28	Bracket Model 4200 DCO Model 3100 DCO	P-01239 P-02646
12	Head Screw 8/unit	P-4025	29	Square Key	P-4040
13	Lock Washer 12/unit	P-4026	30	Not Supplied	
14	Cylinder Heat 2/unit	P-3875	31	Retaining Ring	P-4041
①⑤	Head Gasket 2/unit	P-3866	32	Fan	P-3873
①⑥	Valve Outlet 2/unit	P-3867	33	Shroud	P-3871
①⑦	Valve Plate 2/unit	P-3870	③④	Manifold Sleeve 2/unit	P-3864
①⑧	Valve Inlet 2/unit	P-3868	35	Manifold Nut 2/unit	P-4043
①⑨	Cylinder Gasket 2/unit	P-3869	36	Manifold	P-01240

**NOTE:** When ordering spare parts - 2/unit, etc., refers to number of parts required, NOT UNIT OF MEASURE.

## 8.6. Heatless Dryer Maintenance (Figure 16)

Open the front panel. No field adjustments are necessary on the heatless dryer. No lubrication is required. It is recommended, however, that at intervals the unit be inspected as follows:

The HEATLESS DRYER has a timer motor which switches from one tower to the other every 30 seconds. This can be heard as an air purge. If this air purge cannot be heard, refer to the Troubleshooting Guide for correct diagnosis.

**Note:** No routine maintenance required for desiccant. At 2 years-8000 hour intervals, install maintenance kit P-200-499. The procedure is as follows:

- a. Remove the HEATLESS DRYER unit from the air dryer and remove the AIR MANIFOLD COVER.
- b. Remove MUFFLERS (if equipped) and lock nut and washer.
- c. Remove locknuts, washers, frames and coils.
- d. Using 1-1/16" wrench, remove base assembly containing core assembly and discard.
- e. Remove O-rings from manifold and install new O-rings (P-400-313-018).
- f. Install new base assembly (P-400-308-13) containing new core (P-400-308-12) in manifold. Do not overtorque. Tighten only until snug.
- g. Reinstall coils in the frame. Position spring spacers with light spacer beneath coil, between coil and frame and heavy spacer below frame.
- h. Install unthreaded nut and secure with lock ring.
- i. Remove desiccant chambers, O-rings and purge orifices.
- j. Remove and discard check valve ball and springs and install new check valve ball (P-400-375) and springs (P-300-507).
- k. Reinstall purge orifices with new O-rings (P-400-312-908), (P-400-313-110).
- l. Reinstall desiccant chambers with O-rings (P-400-312-924). Reinstall heatless dryer.

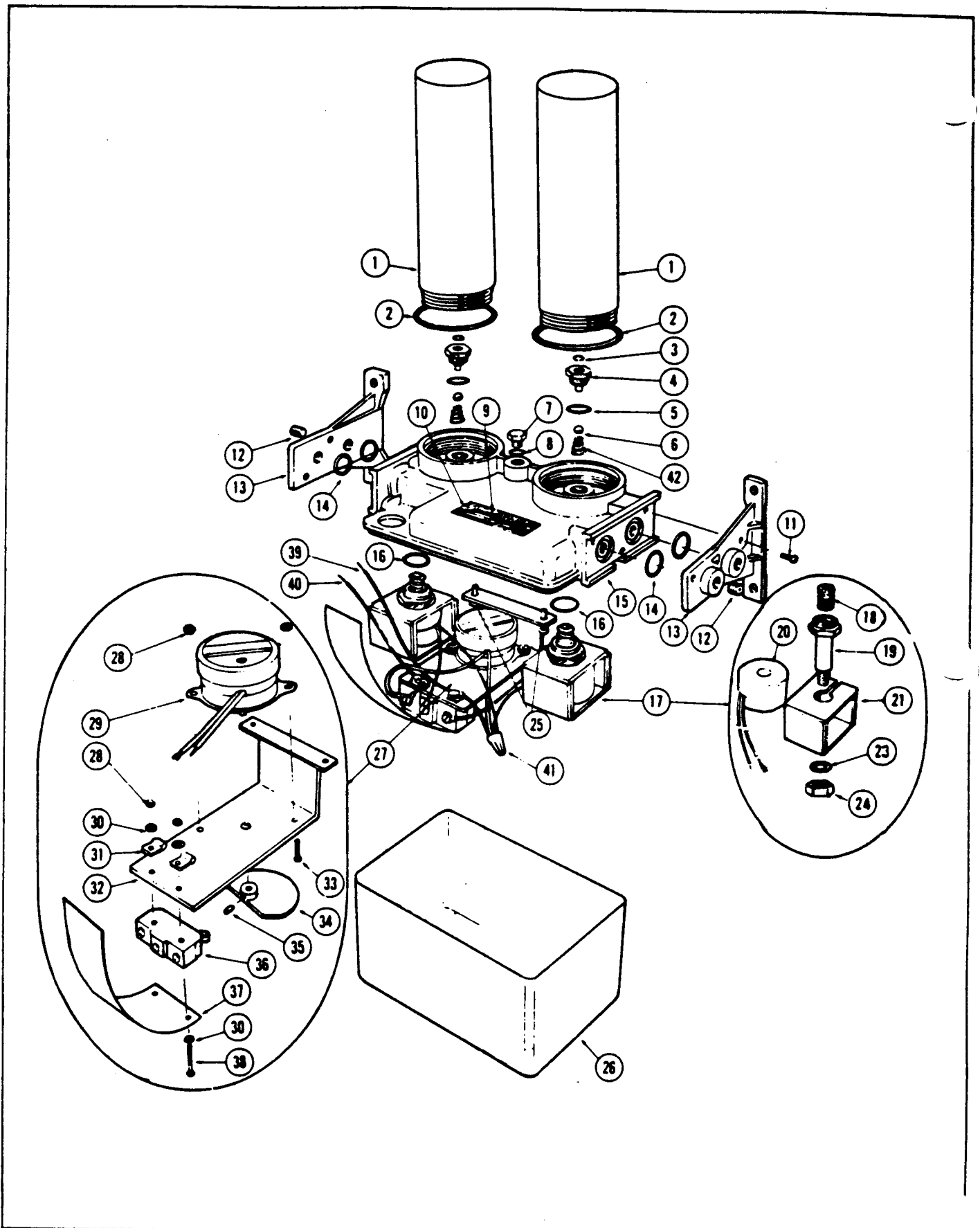

**FIGURE 16**  
**EXPLODED VIEW OF PUREGAS HEATLESS DRYER (DEHYDRATOR)**

P-HF-200-212-041  
P-HF-200-212-034



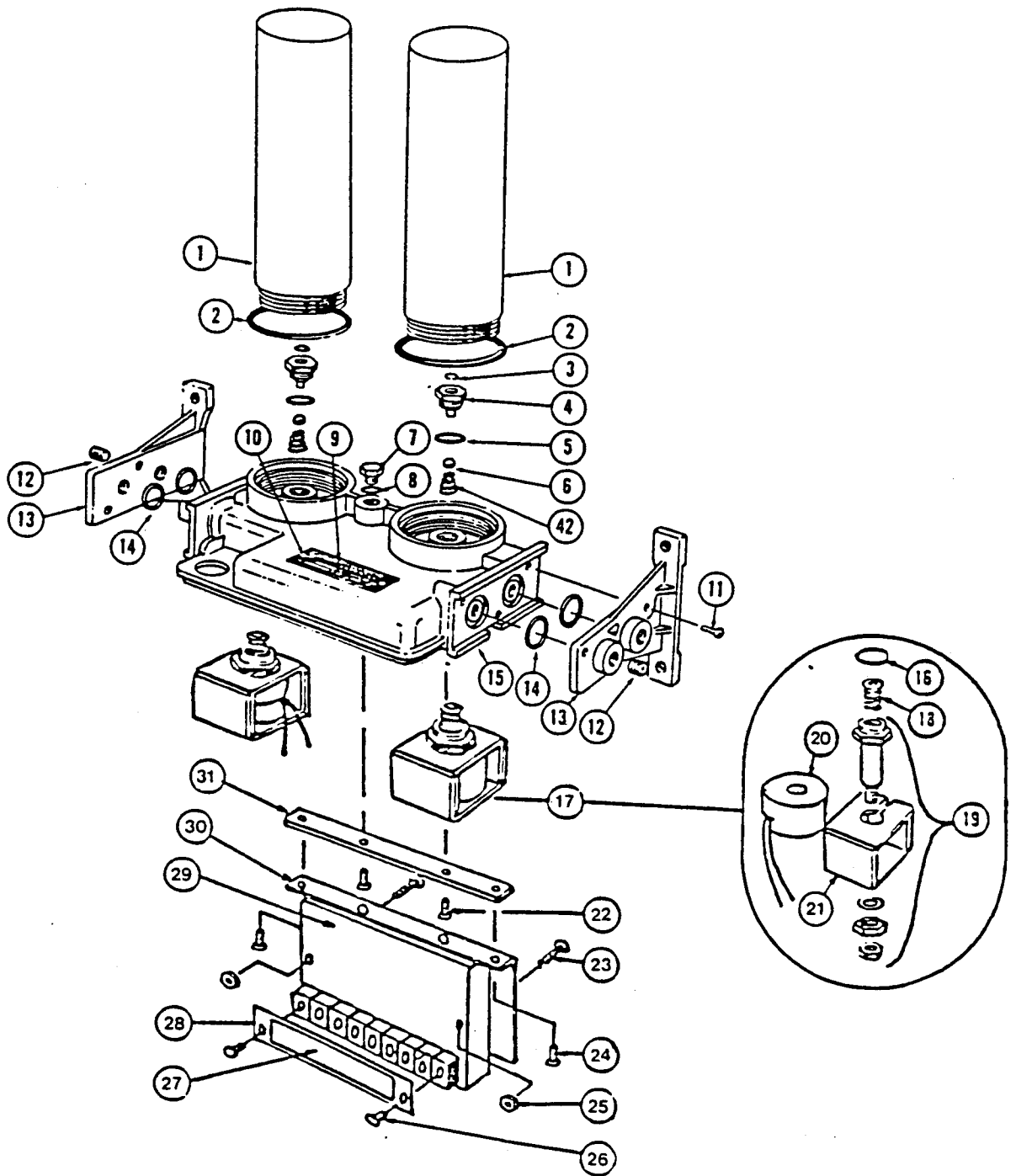

**FIGURE 16A**

**EXPLODED VIEW OF PUREGAS HEATLESS DRYER (DEHYDRATOR) P-HF-2C-212-041  
P-HF-2C-212-034**

PUREGAS HEATLESS DRYER (DEHYDRATOR) P-HF-200 PARTS LIST

See Figure 16, Page 26, for Reference Numbers

○ Denotes Part Included In Maintenance Kit P-200-499 for P-HF-200-212.

Ref. No.	Description	Qty.	Puregas No.	Ref. No.	Description	Qty.	Puregas No.
1	Desiccant Chamber Assembly (Includes item No.2) 12" Chamber Length	2	P-200-403-12	24	Locknut	2	P-400-308-17
②	O-Ring	2	P-400-312-924	25	Screw No.6-32x3/8" pan. Hd.	4	P-400-361-1
③	O-Ring	2	P-400-313-110	26	Air Manifold Cover	1	P-300-505-1
4	Purge Orifice, Fig.13 (Model 3100 Only)	2	P-200-404-34	27	Cycle Timer Assembly:115V., 60 HZ.	1	P-200-306-1
	Purge Orifice, Fig.13 (Model 4200 Only)	2	P-200-404-41	28	Keps-Nut No.6-32	4	Deleted
⑤	O-Ring	2	P-400-312-908	29	Cycle Timer Motor: 115 V., 60 HZ.	1	P-200-385-1
⑥	Ball, Check Valve	2	P-400-375	30	Washer, Flat No.6, bronze	4	P-400-366-6
7	Plug, Hex	1	P-400-307-4	31	Cable.Clip. 1/8" nylon	2	P-400-318-1
8	O-Ring	1	P-400-312-904	32	Motor & Switch Bracket	1	P-300-504
9	Nameplate	1	P-300-737	33	Screw.No 6-32 x 1/4" rnd.hd. brass	2	Deleted
10	Drive Screw No. 4x3/16" Type U rnd. Hd.,st.st.	2	P-400-322-1	34	Cam (includes item No. 35)	1	P-200-406
11	Screw, No. 10-24 x 5/8" Pan.Hd	6	P-400-361-2	35	Set Screw No. 6-32 x 1/8" socket Hd.,st.st.	1	H-SL89-OFC-01
12	Pipe Plug, 1/4"-18 socket hd.	2	P-400-320-3	36	Switch	1	P-400-311
13	Mounting Bracket	2	P-300-497P	37	Terminal Shield	1	P-300-565
14	O-Ring	4	P-400-313-209	38	Screw,No.6-32x1 1/8" rnd.hd., brass	2	P-400-315-3
15	Air Manifold	1	P-300-495	39	Wire, 18 ga.	1	P-200-324-1
⑬	O-Ring	2	P-400-313-018	40	Wire, 18 ga. with terminal	1	P-200-325-1
17	Solenoid Valve Assembly: 115V-60 HZ	2	P-400-308-1	41	Connector	1	P-400-317-1
⑱	Core Assembly	2	P-400-308-12	⑫	Spring, Check Ball	2	P-300-507
⑲	Base Assembly	2	P-400-308-13				
20	Coil	2	P-400-308-11				
21	Frame	2	P-400-308-14				
23	Lockwasher, Rubber Insert	2	P-400-308-16				

**PUREGAS HEATLESS DRYER (DEHYDRATOR) P-HF-2C PARTS LIST**

See Figure 16A, Page 26A for Reference Numbers

○ Denotes Part included in Maintenance Kit P-200-499S

	<b><u>DESCRIPTION</u></b>	<b><u>QTY.</u></b>	<b><u>PART NO.</u></b>
②	O-Ring	2	P-400-312-924
③	O-Ring	2	P-400-313-110
⑤	O-Ring	2	P-400-312-908
⑥	Ball, Check Valve	2	P-400-375
⑩	O-Ring	2	P-400-313-018
17.	<b>SOLENOID VALVE ASSEMBLY</b>		
	53 VDC (for 110 VAC 50/60 Hz dryers)	2	P-400-308-DC1
	106 VDC (for 220 VAC 50/60 Hz dryers)	2	P-400-308-DC2
⑯	Core Assembly	2	P-400-589-12
⑰	Base Assembly	2	P-400-589-13
20.	<b>COIL</b>		
	53 VDC	2	P-400-308-DC11
	106 VDC	2	P-400-308-DC21
22.	Screw No. 6-32X x 3/8" PAN. HD.	2	P-400-361-1
23.	Screw No. 3-32 x 1", BH	2	H-SB83-OHC-10
24.	Screw No. 6-32 x 1 1/4" BH	2	H-SB83-OFC-04
25.	Nut, KEPS 8-32	2	H-NK01-OHC-R5
26.	Screw No. 6-32 x 1/2"	2	H-SB83-OFC-02
27.	Decal Terminal Cover	1	P-06498
28.	Cover Terminal	1	P-06499
29.	<b>SOLID STATE TIMER</b>		
	110 V 50/60 Hz	1	P-06521-F1
	220 V 50/60 Hz	1	P-06521-F2
30.	Bracket - Mtg. SS Timer	1	P-06497
31.	Plate - Adapter - SS Timer Brkt	1	P-06496
④	Spring, Check Ball	2	P-300-507

*\*NOTE: The quantity listed above is for 1 complete dehydrator.*

**8.7. Miscellaneous Maintenance**

- a. Replace the air compressor intake filter muffler elements (P-02619 muffler, P-3986 element).
- b. Clean the air precoolers.
- c. Clean or replace cabinet filter element (P-05893).

**8.8. Pressure Regulator Maintenance**

No preventative maintenance is required; however, if the PRESSURE REGULATOR becomes erratic or inoperative refer to Figure 17, Page 29 for parts breakdown, assembly and disassembly.

**8.9. Bypass Solenoid Valve**

The BYPASS SOLENOID VALVE does not require maintenance; however, if the valve does become defective, refer to Figure 18 , Page 30, for parts breakdown assembly and disassembly.

**Note:** It is normal for the solenoid valve to be warm/hot during operation.

**8.10. Humidity Alarm Calibration**

To calibrate the HUMIDITY ALARM, press the "SET" button and rotate the alarm calibration potentiometer until the L.E.D. just de-energizes. Release the set button and the L.E.D. will energize. Refer to Figure 8 , Page 15 for location of the set button.

**WARNING**

**DO NOT MEASURE SENSING ELEMENT RESISTANCE OR IN ANY WAY APPLY D.C. VOLTAGE TO THE SENSING ELEMENT.**

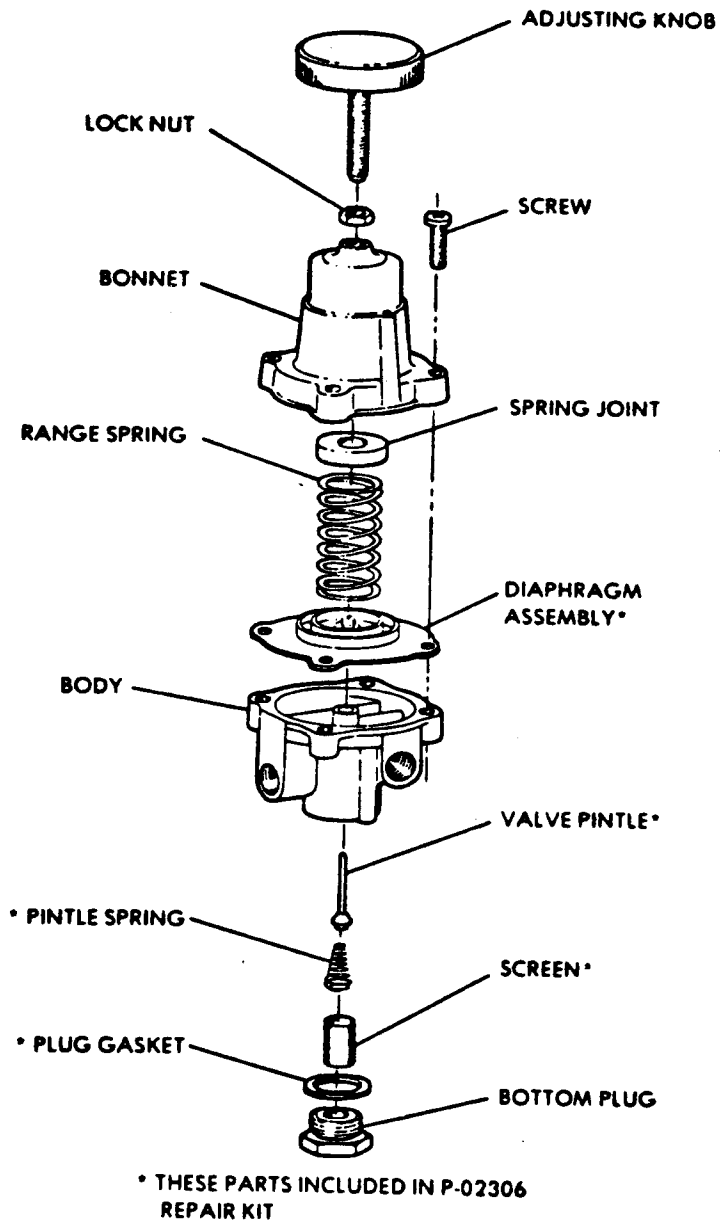

**PRESSURE REGULATOR P-03348**

Figure 17

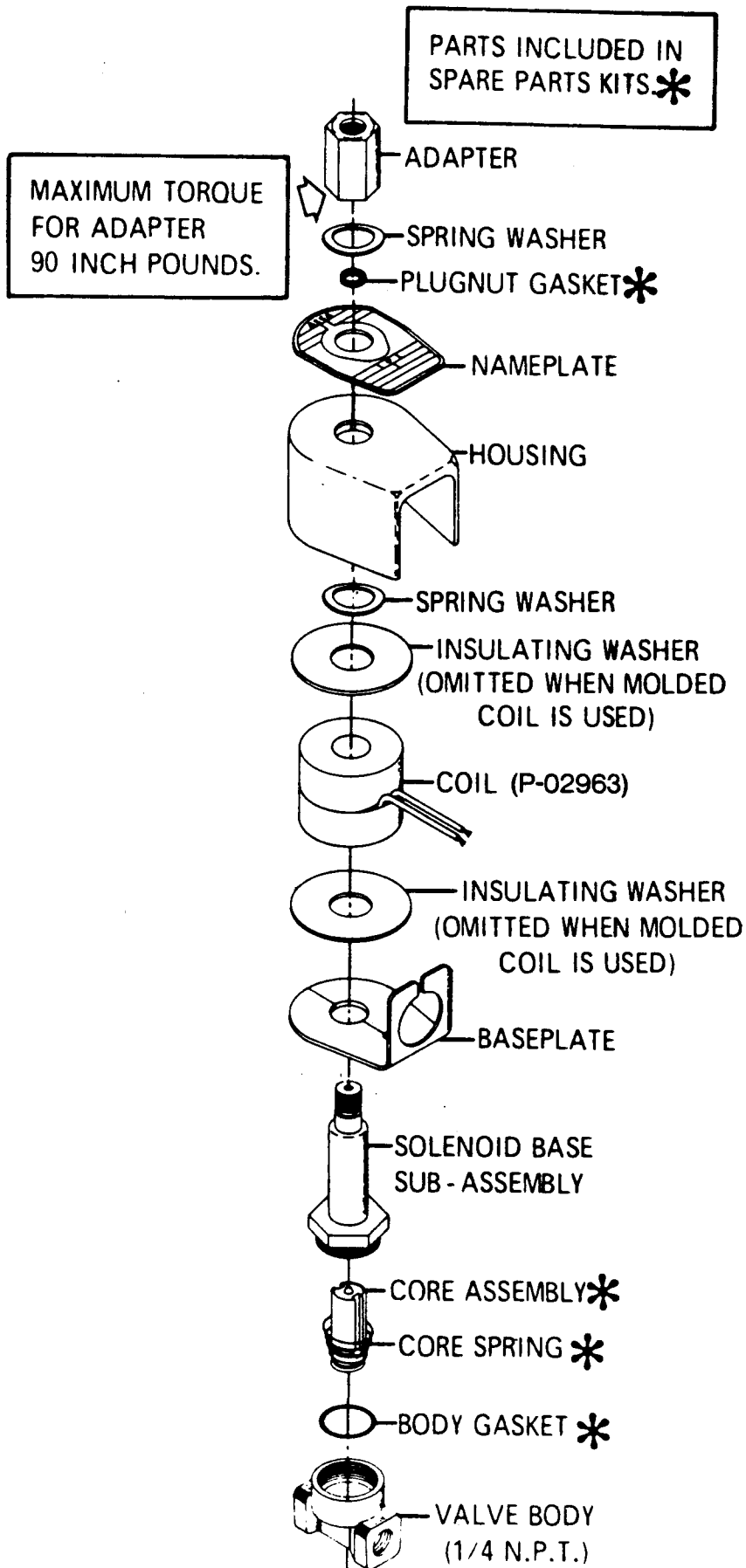

**Bypass Solenoid Valve P-5000-12-85**  
**Bypass Solenoid Maintenance Kit P-02964**

Figure 18

DIGITAL ALARM DISPLAY  
AND  
HUMIDITY INDICATORS

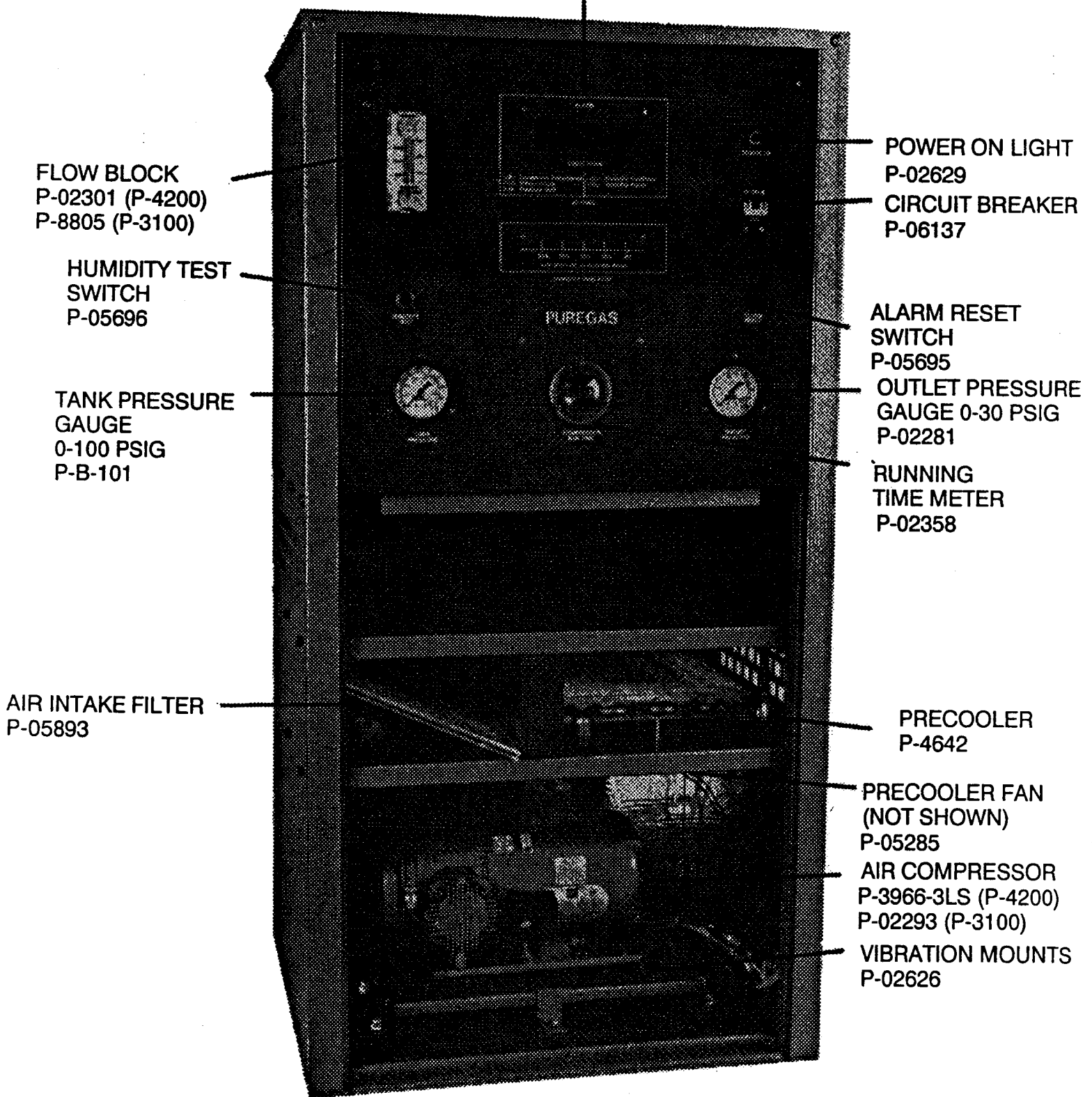

AIR DRYER UNIT FRONT VIEW  
FIGURE 19

HUMIDITY TUBE  
P-4601  
SENSOR (NOT SHOWN)  
P-5000-6-47D

HIGH-LOW PRESSURE  
SWITCH  
P-05648

COMPRESSOR PRESSURE  
SWITCH  
P-4564

BYPASS  
SOLENOID VALVE  
(3-WAY)  
P-5000-12-85

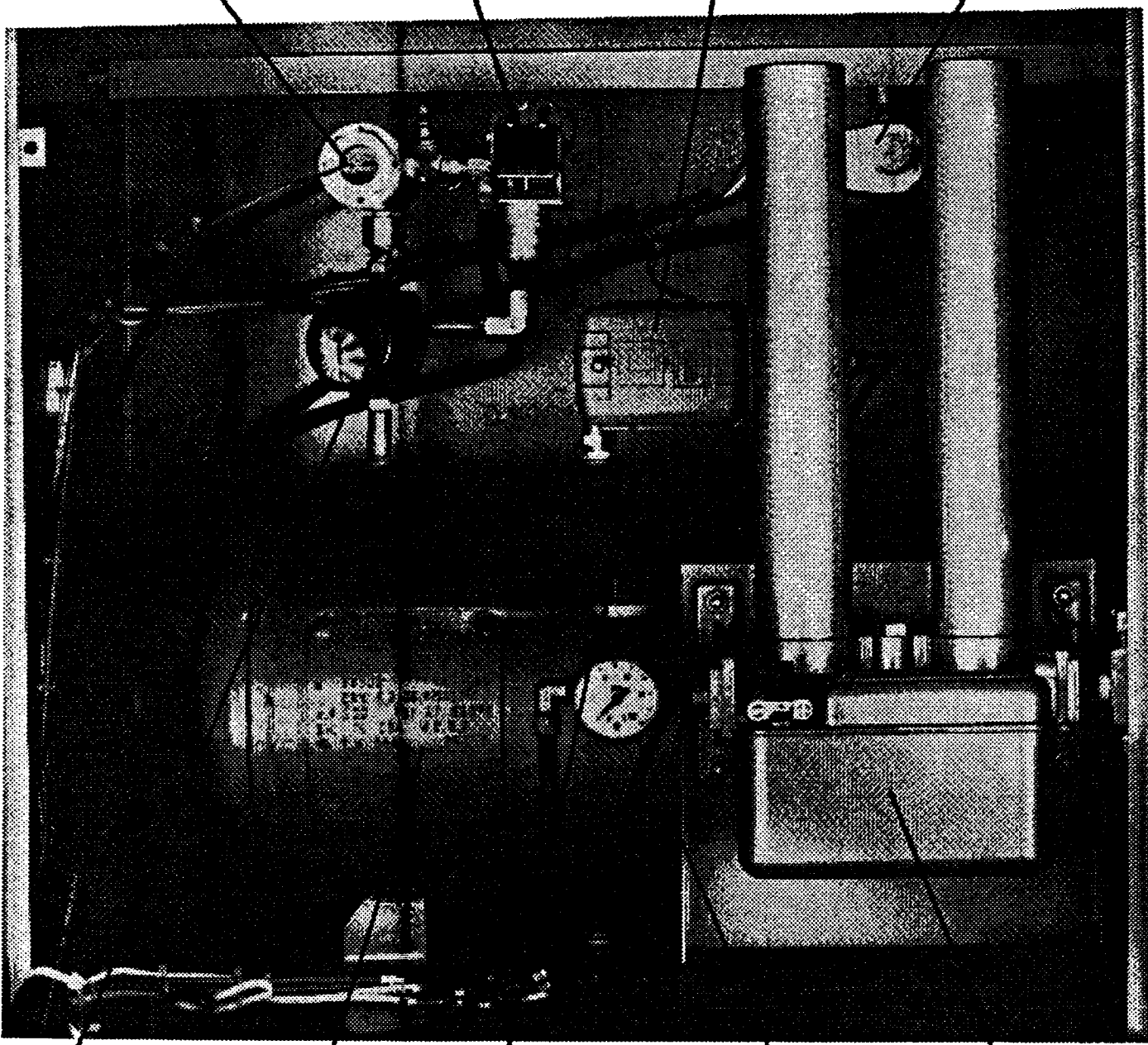

PRESSURE  
REGULATOR  
P-03348

DRY AIR STORAGE  
TANK  
P-02409

CAPACITY  
CONTROL VALVE  
P-4634

PRESSURE  
GAUGE  
0-100 PSIG  
P-3197

HEATLESS DRYER  
(P-4200) P-HF 200-212-041  
(P-3100) P-HF200-212-034  
SOLID [ P-HF2C-212-041  
STATE [ P-HF2C-212-034

**AIR DRYER UNIT TOP COMPARTMENT FRONT VIEW**

FIGURE 20



HUMIDITY BOARD  
P-05521

TOP SSR BOARD  
P-05846

ALARM RESET  
SWITCH  
P-05695

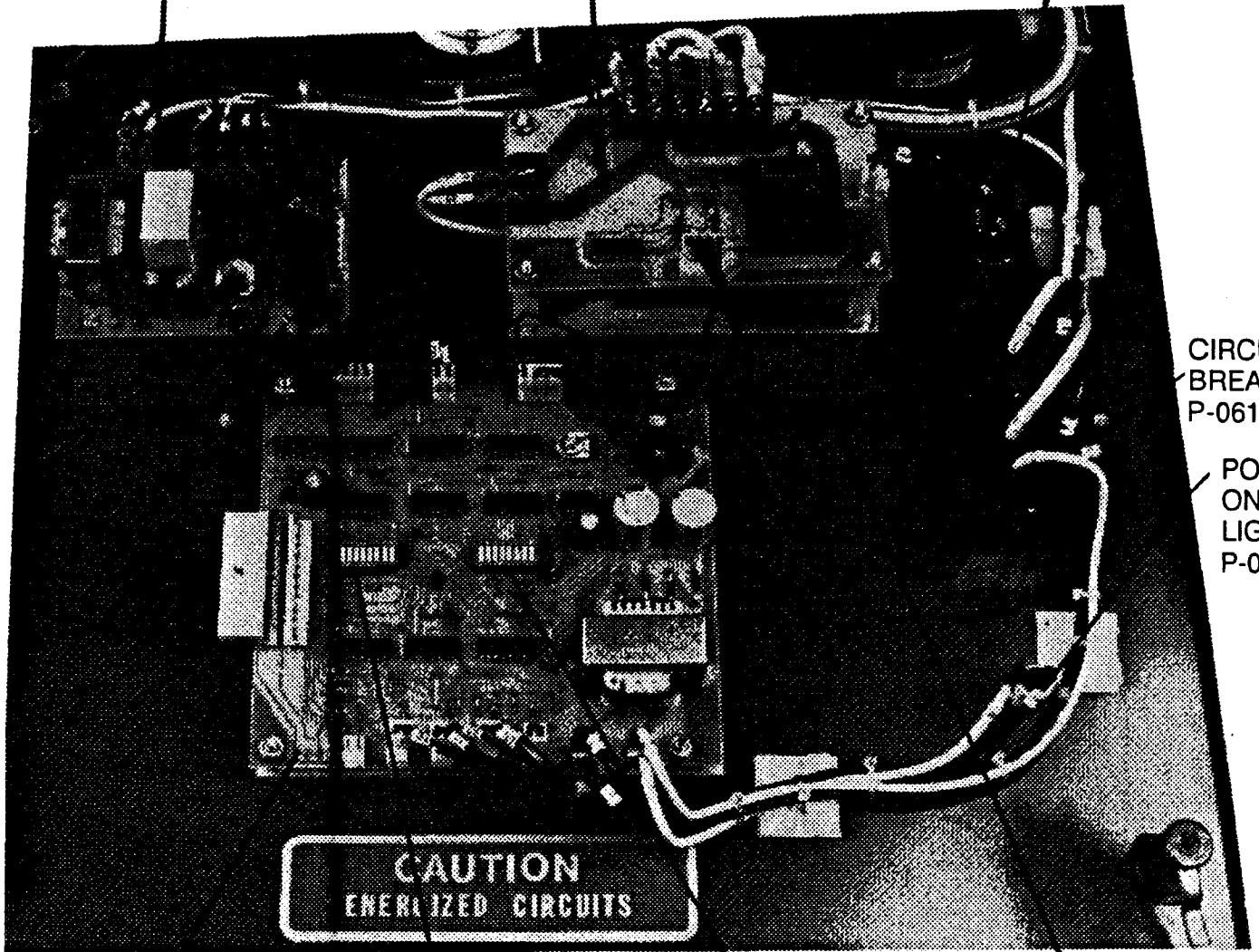

CIRCUIT  
BREAKER  
P-06137

POWER  
ON  
LIGHT  
P-02629

LOGIC BOARD  
P-05847  
DISPLAY BOARD  
(LOCATED  
UNDERNEATH  
LOGIC BOARD)  
P-05627

HUMIDITY SWITCH  
DELAY SWITCH  
(REFER TO FIG. 3)

COMPRESSOR  
PERFORMANCE  
TIME DELAY  
SWITCH  
(REFER TO  
FIG. 4)

BOTTOM  
SOLID STATE  
RELAY (25 AMP)  
P-06101

## AIR DRYER UNIT TOP FRONT DOOR

FIGURE 21

## 9.0.

MAINTENANCE MATRIX AND PARTS SUMMARY

<u>Model</u>	<u>Maintenance Procedure Refer To Manual</u>	<u>Freq. Interval</u>	<u>Time (Min.) Required</u>
P-3100/4200DC0	• Flowrate - Check	A	1
	• Humidity Alarm - Check	A	5
	• Safety Valve - Check	A	5
	• Compr. Pressure Switch - Check	A	5
	• Hi-Lo Pressure Alarm - Check	A	5
	• Compressor Capacity or Performance - Check	A	5
	• Capacity Control Valve - Check	A	5
	• Ventilation Fan - Check	A	1
	• Compressor Intake Filters - Replace	A	10
	• Precooler - Clean	A	10
	• Vent Fan & Filter - Clean	A	10
	• Compressor Maintenance Kit - Install	B	60
	• Periodic Dryer - Inspection	B	5
	• Heatless Air Dryer Maintenance Kit - Install	C	60

Frequency Interval

A - Every 6 Months.

B - 1 Year or Every 4000 Operating Hours.

C - 2 Years or Every 8000 Operating Hours.

## 9.1.

## RECOMMENDED SPARE PARTS LIST

## PUREGAS P-3100/4200DCO

<u>QUANTITY</u>	<u>PART NO.</u>	<u>DESCRIPTION</u>
4 ea.	P-02626	Vibration Mounts
1 ea.	P-5000-12-85	Humidity Bypass Valve
1 ea.	P-4564	Pressure Switch (On/Off)
1 ea.	P-03745	Fan (Precooler)
1 ea.	P-05521	Humidity Board
2 ea.	P-5000-6-47D	Humidity Sensor
1 ea.	P-05847	Logic Board
1 ea.	P-05627	Display Board
1 ea.	P-05846	SSR Board
1 ea.	P-06101	Solid State Relay (25 AMP)
1 ea.	P-06184	Circuit Breaker
2 ea.	P-400-308-1	Solenoid Valve Assy.
1 ea.	P-200-499	Heatless Dryer Maintenance Kit
1 ea.	P-200-385-1	Cycle Timer Motor
1 ea.	P-07584	Compressor Maintenance Kit
1 ea.	P-4634	Capacity Control Valve

**Note:** Heatless Dryer Maintenance Kits (P-200-499) should be installed every 8000 hrs. of operation.

Compressor Maintenance Kits P-07584 should be installed every 4000 hrs. of operation.

Quantities listed above are recommended parts per air dryer.

Optional Spare Part: P-3966-3LS (4200DCO)  
P-02293 (3100DCO)

## SECTION 10

### TROUBLESHOOTING INFORMATION GUIDE

This Troubleshooting Guide is set in a columnar format to simplify the isolation of problems, possible causes, areas to check and corrective action required to restore the air dryer to normal operation. It is further divided into system headings for easy referral. Where possible, the most likely causes have been listed first. Otherwise, the causes start with the simplest and progress to more complicated possibilities. It is therefore suggested that the steps be followed in sequence to expedite service. It is further suggested that once the problem has been isolated, the corresponding text in the Maintenance Section be reviewed to provide additional information. It is also recommended that after the air dryer has been serviced, the alarms be re-tested to assure that the alarm system is working properly.

#### ALARM TROUBLESHOOTING GUIDES

Pages represent the Alarm Troubleshooting Guides. These Guides are set in a flow chart format and should be used when indicated in the normal columnar troubleshooting guide preceding this section. The Alarm Troubleshooting Guides will breakdown the procedure when isolating a malfunction with the air dryer. The Alarm Troubleshooting Guides are very easy to use and very effective when used properly. Therefore, it is suggested when entering one of the Guides, always start at the beginning and continue in sequence by reading the paragraph and following the procedures indicated, then read the question and answer accordingly (yes or no). The answer will lead into the next step or possibly the cause of the malfunction.

The Troubleshooting Information Guide can by no means cover every possible cause for malfunction, but following these procedures as outlined will solve most problems. If the problem persists after thoroughly consulting the Troubleshooting Section, contact General Cable Company, Puregas Technical Service Department at (303) 427-3700.

#### DANGER

This section requires access to components inside the cabinet of the air dryer. In most cases, an energized and operating air dryer is necessary to conduct test and make adjustments. Extreme care should be exercised to avoid contact with live electrical or moving parts.

## 10.1. TROUBLESHOOTING GUIDE

### 10.1.1. Air System

<u>Problem</u>	<u>Possible Cause</u>	<u>Check</u>	<u>Correction Action</u>
#1 Air compressor will not operate. Light on the front panel will not energize.	A.1. Power has been interrupted to the air dryer.	The main circuit breaker or fuse panel.	Reset the circuit breaker or replace the fuse.
	A.2. A faulty electrical connection at the incoming power terminal block located in the air dryer.	Disconnect electrical power at the supply source and carefully inspect the wire connectors and terminal block connections.	Replace wire connectors and tighten terminal block connections as necessary. Reinststate power to the unit.
	A.3. The air dryer circuit breaker has tripped.	Inspect front panel ON/OFF switch (circuit breaker).	Reset as necessary.
	A.4. A faulty electrical connection at the power supply triac board or logic circuit board.	Disconnect electrical supply power. Now carefully inspect the "slip-on" electrical connections.	Replace defective and loose connections as necessary. Reinststate power to unit.
#2 Heatless dryer delivers wet air.	A.1. Defective solenoid valve.	Check core assembly for broken spring and proper seating.	Defective parts should be replaced (core, assembly or worn parts).
	A.2. Purge orifice plugged.	Check orifice for residue.	Clean orifice with air pressure (do not use wire or anything abrasive that will damage orifice).
	A.3. Solenoid coil burned out.	Check magnetic pull of coil with screwdriver (refer to A.4. before replacing coil). Note: Each coil should be energized every 30 seconds.	Replace if necessary.
	A.4. Improper operation of cycle timer.	<ol style="list-style-type: none"> <li>1. Check power supply.</li> <li>2. Check rotation of timer motor (should be 1 RPM).</li> <li>3. Check cam for tightness on shaft.</li> <li>4. Check switch lever by hand.</li> <li>5. Check to make sure switch is secured properly (should be away from cam).</li> <li>6. Check cam for make or break every 30 seconds. If switch operates less than 29 seconds or more than 31 seconds, check cam for excessive wear.</li> </ol>	<p>Locate power loss.</p> <p>Check motor if not rotating.</p> <p>Tighten cam or replace.</p> <p>Replace switch/lever if no clicking contact is heard.</p> <p>Secure or adjust.</p> <p>Replace cam if specifications are not met.</p>

10.1. TROUBLESHOOTING GUIDE (continued)

<u>Problem</u>	<u>Possible Cause</u>	<u>Check</u>	<u>Correction Action</u>
#2 (continued)	A.5. Deteriorated desiccant towers.	Check movement of perforated disc at open end of chambers (disc should not depress more than 1/4" from retaining ring).	Replace chamber or have it repacked. (Puregas recommends towers be repacked at the factory.)
#3 Heatless dryer has excessive drop in outlet pressure.	A.1. Improper operating conditions.	See Problem #2, A.1.	
	A.2. Solenoid coil burned out.	See Problem #2, A.3.	
	A.3. Improper operation of cycle timer.	See Problem #2, A.4.	
	A.4. Check valve balls seated properly	Check balls and springs for excessive leak or damage.	Replace if necessary.
#4 Compressor will not build pressure	A.1. Compressor requires maintenance.	Check rings and valves for excessive wear.	Change maintenance kit.
	A.2. Capacity control valve is defective or requires adjustment.	Check capacity control valve for proper adjustment.	Adjust to 50 $\pm$ 2 PSI
#5 -HC- appears at the alarm display.		See Paragraph 5.1.4 On Page 9.	
#6 -HA- appears at the alarm display		See Paragraph 5.1.5 on Page 9 and proceed to the Humidity Alarm Guide on Page 39.	
#7 -P-LO- appears at the alarm display.		See Paragraph 5.1.2 on Page 9 and proceed to the Low Pressure Alarm Guide on Page 40.	
#8 -P-HI- appears at the alarm display.		See Paragraph 5.1.1 on Page 9 and proceed to the High Pressure Alarm Guide on Page 41.	
#9 -CP- appears at the alarm display.		See Paragraph 5.1.3 on Page 9 and proceed to the Compressor Performance Alarm Guide on Page 42.	

P-3100/4200 DCO HUMIDITY ALARM TROUBLESHOOTING GUIDE

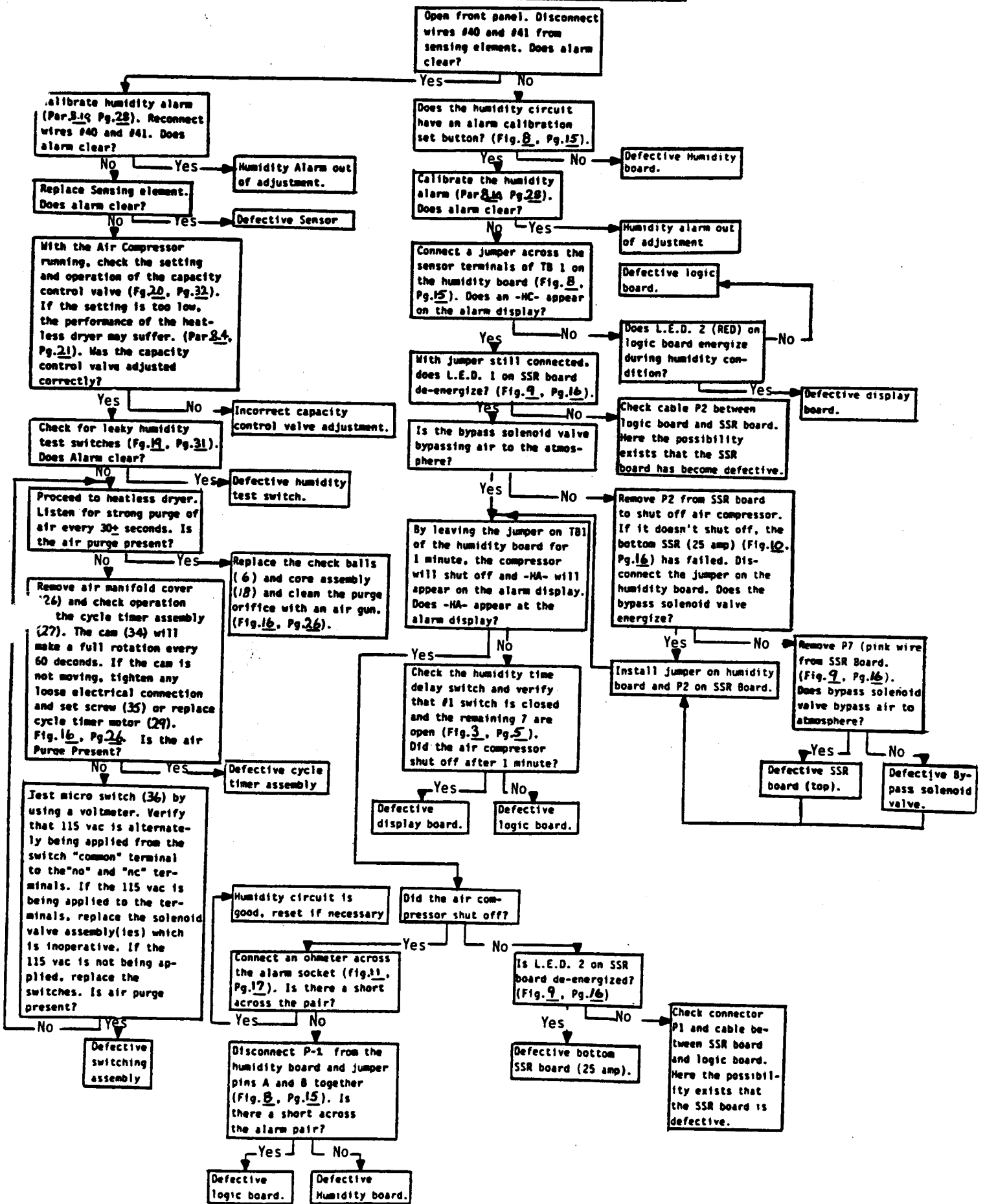

Figure 22.

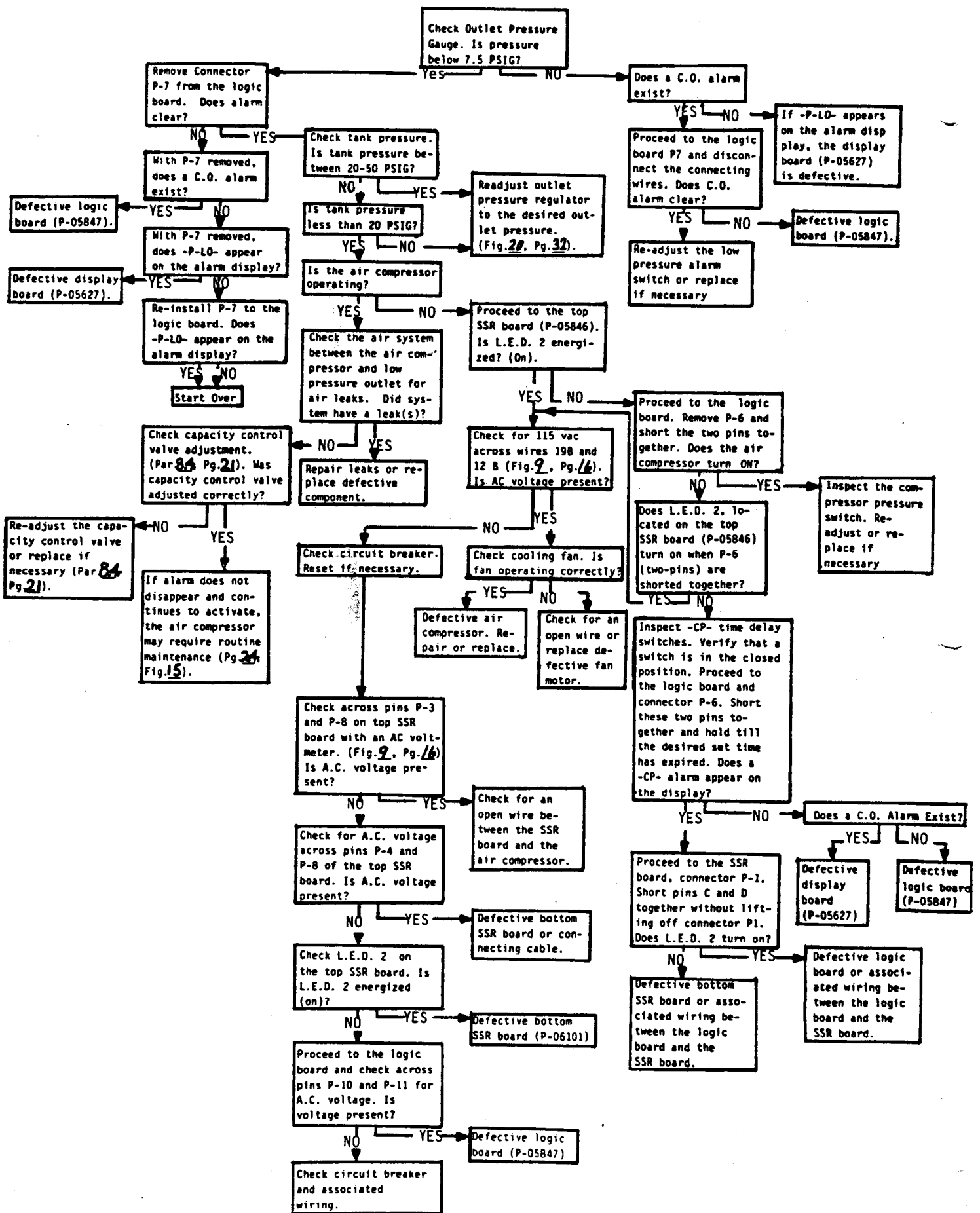

Figure 23



P-3100/4200 DCO HIGH PRESSURE TROUBLE SHOOTING GUIDE

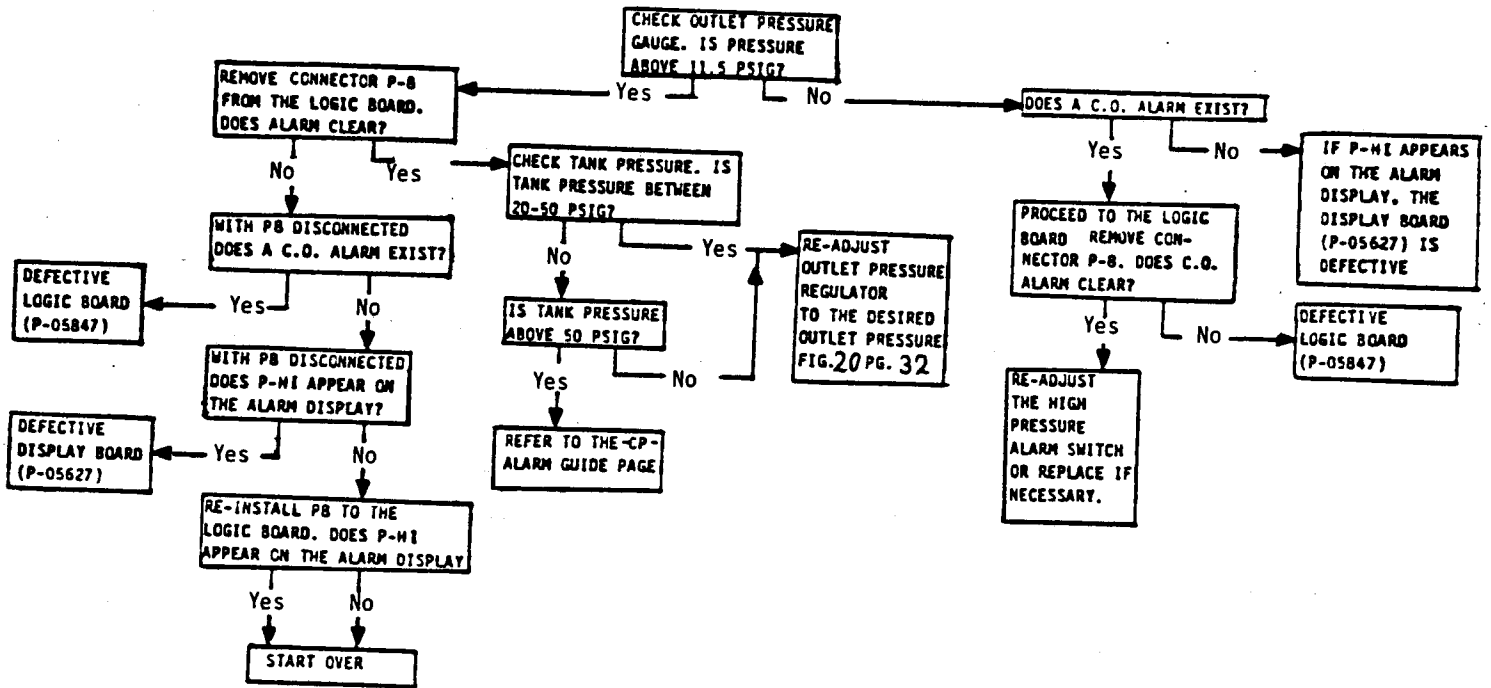

Figure 24.

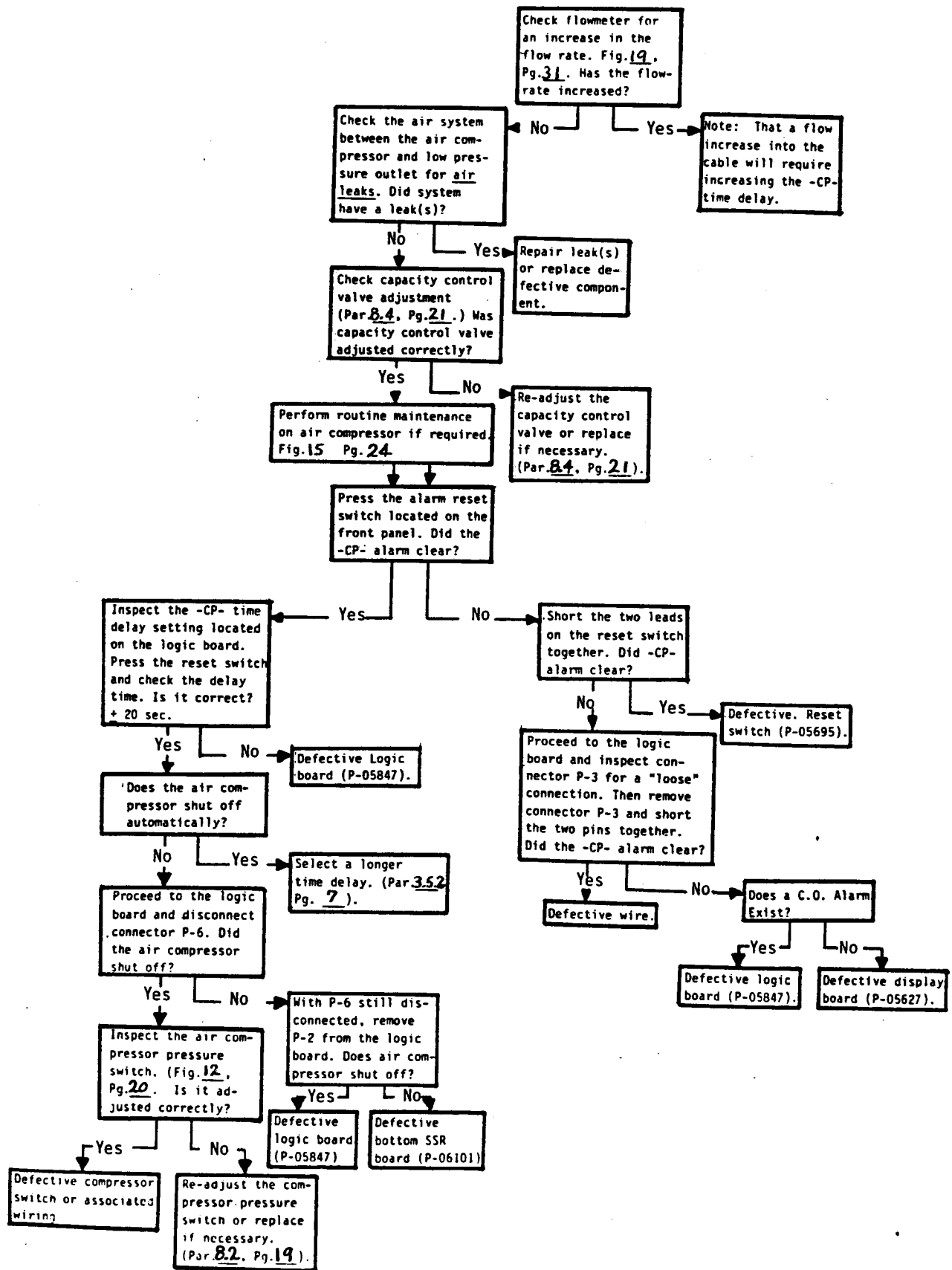
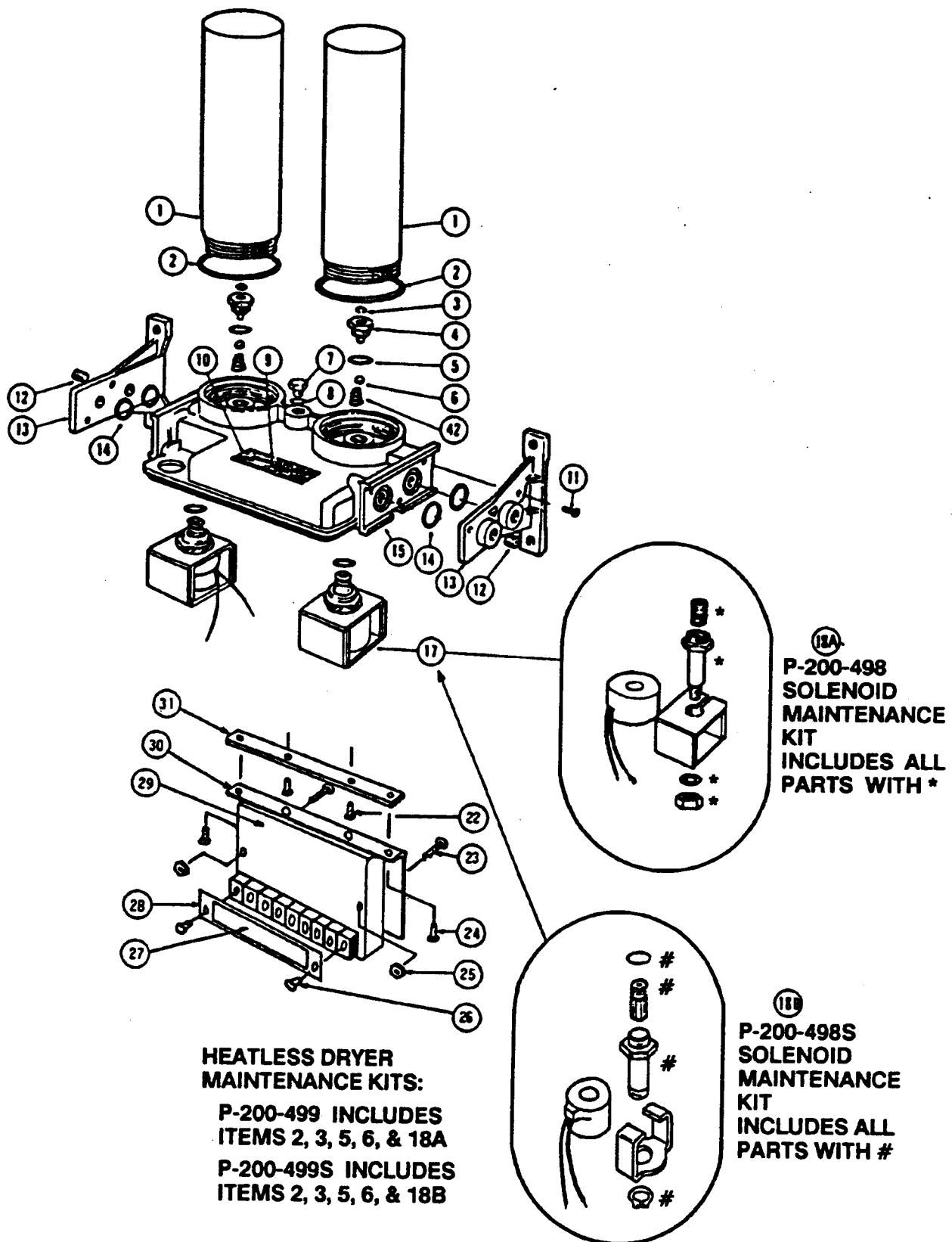

Figure 25.



**EXPLODED VIEW OF PUREGAS HEATLESS DRYER  
 WITH SOLID STATE TIMER  
 (DEHYDRATOR)**

**PARTS LIST**  
**Refer to Previous Addendum Page for**  
**Figure of PUREGAS HEATLESS DRYER**

DESCRIPTION	*QTY.	PART NO.
17. Solenoid Valve Assembly		
18A. 53 VDC (For 110 VAC 50/60 HZ Dryers).....	2	P-400-308-DC1
106 VDC (For 220 VAC 50/60 HZ Dryers).....	2	P-400-308-DC2
18B. 53 VDC (For 110 VAC 50/60 HZ Dryers).....	2	P-400-589-DC1
106 VDC (For 220 VAC 50/60 HZ Dryers).....	2	P-400-589-DC2
20. Coil		
(18A) 53 VDC.....	2	P-400-308-DC11
106 VDC.....	2	P-400-308-DC21
(18B) 53 VDC.....	2	P-400-589-DC11
106 VDC.....	2	P-400-589-DC21
22. Screw No. 6-32x3/8" Pan. Hd.....	2	P-400-361-1
23. Screw No. 3-32x1", BH.....	2	H-SB83-OFC-10
24. Screw No. 6-32x1 1/4" BH.....	2	H-SB83-OFC-04
25. Nut, Keps 8-32.....	2	H-NK01-OHC-R5
26. Screw No. 6-32x1/2".....	2	H-SB83-OFC-02
27. Decal Terminal Cover.....	1	P-06498
28. Terminal Cover.....	1	P-06499
29. Solid State Timer		
110 V 50/60 HZ.....	1	P-06521-F1
220 V 50/60 HZ.....	1	P-06521-F2
30. Bracket - Mtg. SS Timer.....	1	P-06497
31. Plate-Adapater-SS Timer Brkt.....	1	P-06496

\* NOTE: THE QUANTITY LISTED ABOVE IS FOR 1 COMPLETE DEHYDRATOR

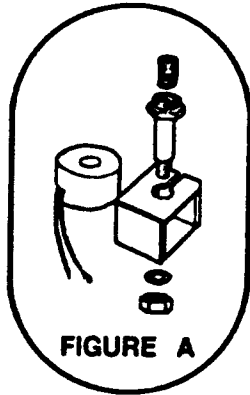

FIGURE A

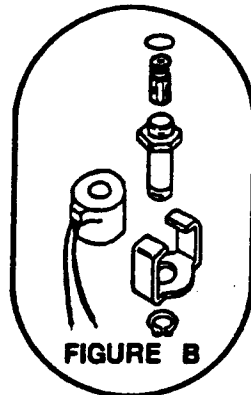

FIGURE B

## MAINTENANCE INFORMATION FOR HEATLESS DRYERS

### I HEATLESS DRYER MAINTENANCE KITS

The kits below apply to Models HF200 and HF2C Heatless Dryers.

1. For solenoid valve like Figure A, order P-200-499 (Heatless Dryer Maintenance Kit)
  - a) For Solenoid Maintenance Kit only, order P-200-498.  
(P-200-498 is included in P-200-499)
2. For solenoid valve like Figure B, order P-200-499S (Heatless Dryer Maintenance Kit)
  - a) For Solenoid Maintenance Kit only, order P-200-498S.  
(P-200-498S is included in P-200-499S)

### II HEATLESS DRYER SOLENOID COIL REPLACEMENT

1. For Heatless Dryer with mechanical timer, and the solenoid valve is like Figure A, order:
  - a) P-400-308-11 for 115 VAC Models
  - b) P-400-308-21 for 230 VAC Models
2. For Heatless Dryer with solid state timer, and the solenoid valve is like Figure A, order:
  - a) P-400-308-DC11 for 115 VAC Models
  - b) P-400-308-DC21 for 230 VAC Models
3. For Heatless Dryer with mechanical timer, and the solenoid valve is like Figure B, order:
  - a) P-400-589-11 for 115 VAC Models
  - b) P-400-589-21 for 230 VAC Models
4. For Heatless Dryer with solid state timer, and the solenoid valve is like Figure B, order:
  - a) P-400-589-DC11 for 115 VAC Models
  - b) P-400-589-DC21 for 230 VAC Models

### III HEATLESS DRYER COMPLETE SOLENOID VALVE ASSEMBLY

1. For Heatless Dryer with mechanical timer, order:
  - a) P-07990-AC1 for 115 VAC Models
  - b) P-07990-AC2 for 230 VAC Models
2. For Heatless Dryer with solid state timer, order:
  - a) P-07990 DC1 for 115 VAC Models
  - b) P-07990 DC2 for 230 VAC Models

**NOTE:** Puregas recommends the use of the P-07990 DC Series valves to eliminate possible excessive chattering; however, the P-07990 AC Series may also be used. The new solid state timer will operate either AC or DC valves or a combination of both.

**Important:** When connecting solenoid valves to the solid state timer, connect P-07990 AC Series valves to the "AC" terminals and P-07990 DC Series valves to the "DC" terminals.