

# ***Refrigerated Non-Cycling Series Air Dryers***



## **User's Guide**

Models covered:

*RAD-0025 through RAD-2000    RHT-0010 through RHT-0120*



## 1. Welcome & Congratulations

Congratulations on your purchase of a new Altec AIR *Refrigerated Non-Cycling Series* Air Dryer! We here at Altec AIR are very proud of our products and we are committed to providing you with the best value and service possible.

We are sure that you will be satisfied with your new Air Dryer and would like to thank you for choosing Altec AIR for your Air Dryer requirements. We also hope that you will continue to choose us for your future compressed air treatment purchases.

For information about this and other Altec AIR products, please visit us on the web at:

[www.AltecAIR.com](http://www.AltecAIR.com)

## 2. Introduction

**PLEASE READ THIS USER'S GUIDE THOROUGHLY AND SAVE FOR FUTURE REFERENCE.**

This User's Guide is provided for the benefit of our customers and contains information and direction specific to the Altec AIR *Refrigerated Non-Cycling Series Air Dryers*. Models covered include *RAD-0025 through RAD-1250 and RHT-0010 through RHT-0120*. This guide covers topics including safety, specifications, installation, registration, operation, testing, maintenance, replacement parts, service, and troubleshooting issues. Observation and compliance with this User's Guide will ensure the maximum life and efficiency of your Air Dryer.

This User's Guide should be read thoroughly prior to installing, operating, or servicing the Air Dryer in order to become familiar with the recommended procedures. This will minimize the possibility of personal injury or damage to the Air Dryer due to improper operation or handling.

### 3. Table of Contents

<b>1. Welcome &amp; Congratulations .....</b>	<b>2</b>	9.1 Safety & Warning Information .....	26
<b>2. Introduction.....</b>	<b>2</b>	9.2 Regular Maintenance .....	26
<b>3. Table of Contents .....</b>	<b>3</b>	<b>10. Troubleshooting Your Air Dryer ....</b>	<b>27</b>
<b>4. Safety &amp; Warning Information .....</b>	<b>4</b>	10.1 Before You Call Altec AIR.....	27
<b>5. Overview &amp; Specifications .....</b>	<b>6</b>	10.2 Safety & Warning Information .....	28
5.1 Product Description .....	6	10.3 Air Dryer Not Performing – High	
5.2 Key Features.....	6	Outlet Dew Point .....	29
5.3 Refrigerated Non-Cycling Series Air		10.4 Condensate in Piping After Air Dryer	
Dryer Models .....	7	.....	29
5.4 Technical Specifications .....	8	10.5 Contacting Altec AIR Technical	
5.5 Air Dryer Function Overview.....	12	Support.....	30
<b>6. Installing Your Air Dryer .....</b>	<b>14</b>	<b>11. Replacement Parts &amp; Accessories .31</b>	
6.1 Safety & Warning Information .....	14	11.1 Air Dryer Diagram, Image, Explosion	
6.2 Before You Begin .....	15	w/ Part List .....	31
6.3 Installation Configuration .....	17	11.2 Accessories .....	37
6.4 Included Contents .....	18	11.3 Ordering Parts from Altec AIR .....	38
6.5 Required Tools and Materials .....	18	<b>12. Contacting Altec AIR.....</b>	<b>39</b>
6.6 Installation Steps.....	18	12.1 General.....	39
<b>7. Registering Your Air Dryer .....</b>	<b>21</b>	12.2 Sales .....	39
<b>8. Operating Your Air Dryer .....</b>	<b>22</b>	12.3 Service .....	39
8.1 Air Dryer Access.....	22	12.4 Technical Support.....	39
8.2 Refrigerant Manifold Attachment.....	22	<b>13. Appendix .....</b>	<b>40</b>
8.3 Drain Valve Operations .....	23	13.1 Wiring Diagram .....	40
8.4 Hot Gas Bypass Valve Adjustments		13.2 P Series Timer – Add on Option .....	48
(HGBV) .....	24	13.3 Zero Loss Drain – Add on Option ...	52
8.5 Thermostatic Expansion Valve		13.4 Digital Scroll Option .....	59
Adjustments (TXV).....	25	<b>14. Warranty Statement.....</b>	<b>60</b>
<b>9. Maintaining Your Air Dryer.....</b>	<b>25</b>	Registration Reminder .....	60
		<b>15. Notes .....</b>	<b>61</b>

## 4. Safety & Warning Information

This section contains general information about safety and warning points to consider and adhere to during installation, operation, and maintenance of your Air Dryer. PLEASE READ THIS SECTION BEFORE PERFORMING ANY OPERATION OR PROCEDURE ON YOUR AIR DRYER.

Additional warnings specific to an operation or procedure will also be presented throughout the following sections. These will include the ANSI safety alert symbol as well as a label of “**WARNING!**”, “**CAUTION!**”, or “**NOTICE!**”. Please be sure to pay close attention for these warnings and read them as you encounter them.



### **WARNING!**

For your safety, all the information in this User's Guide must be followed to minimize the risk of electrical shock, and prevent property damage or personal injury.



### **WARNING!**

Stored energy hazardous voltage. Be sure all capacitors are discharged before servicing unit.



### **WARNING!**

Extreme care should be exercised to avoid contact with live electrical circuits. Many procedures performed during installation, operation, testing, and maintenance of this Air Dryer require the equipment to be running, creating a situation for potential electrical shock. It is highly recommended that you remove all jewelry before performing any procedures.

**WARNING!**

To avoid electrical overload and shock hazard, incoming power to Air Dryer must be sized according to Air Dryer specifications – refer to Air Dryer Electrical Information in Section 5.4.2

**CAUTION!**

**Internal surfaces may be hot.** Use care when coming into contact with internal components as there is a potential for some of these components to become hot when in operation or standby.

**CAUTION!**

Proper Installation & Maintenance as outlined in this User's Guide is extremely important to ensure the reliability and longevity of the equipment as well as prevent damage or personal injury.

**CAUTION!**

Depressurizing the Air Dryer may be necessary before performing certain procedures.

**NOTICE!**

Performing routine maintenance as outlined in the *Maintaining Your Dryer* section will ensure optimal performance over the lifecycle of your Air Dryer. Performing procedures not recommended by Altec AIR or installing components not supplied by Altec AIR is **NOT RECOMMENDED AND MAY VOID THE WARRANTY.**

## 5. Overview & Specifications

### 5.1 Product Description

This Refrigerated Air Dryer has been specifically designed, manufactured, and tested for the purpose of reducing the humidity in compressed air. Any other use is considered improper. Altec AIR will not be responsible for any problem due to improper use. The outlet air from this product is not intended for use in breathing, food, or other sterile applications.

The proper use requires the following to adhere to the installation instructions:

- Main power source voltage and frequency
- Flow rate, pressure, and temperature of the inlet air
- Ambient temperature
- Inlet air quality (dirty air with solid particles not acceptable)

### 5.2 Key Features

The Refrigerated Non-Cycling Air Dryer Series is designed to meet the demand of your compressed air system with quality components that are built to last. RAD series models range from 25 SCFM to 1250 SCFM, and RHT models range from 10 SCFM to 120 SCFM.

- Consistent & reliable dry air at 45°F outlet dew point for RAD series, or 50°F outlet dew point for RHT Series Air Dryers
- Compact all-aluminum heat exchanger modules with low pressure drops
- Programmable automatic electronic drains
- Easy-access cabinet design for ease of maintenance & serviceability
- Suction pressure gauges provide simple & reliable monitoring of the Air Dryer's refrigeration system
- Top mounted inlet & outlet connections allow for easy installation of Air Dryer, filters, & bypass valves
- Outlet air pressure drop of 2 psi or less at rated conditions

### 5.3 Refrigerated Non-Cycling Series Air Dryer Models

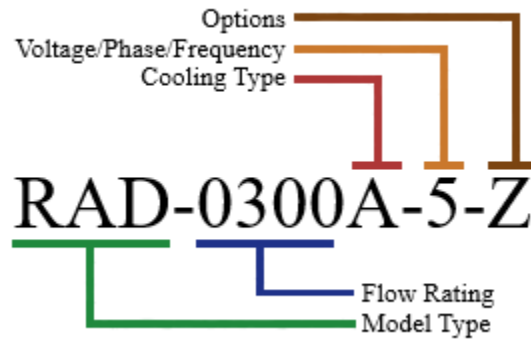

#### Model Type:

- RAD: 100°F saturated, 100 PSIG Inlet Air, 45°F Outlet Dewpoint
- RHT: 180°F, 160°F Dew Point, 150 PSIG Inlet Air, 50°F Outlet Dewpoint

#### Flow Rating:

- RAD Series Flow Rates: 25 - 1250 SCFM
- RHT Series Flow Rates: 10 - 120 SCFM

#### Cooling Type:

- A: Air Cooled
- W: Water Cooled \*\*

#### Nominal Voltage/Phase/Frequency:

- 1: 115V/1Ph/60Hz
- 2: 230V/1Ph/60Hz
- 3: 230V/3Ph/60Hz
- 4: 460V/3Ph/60Hz
- 5: 575V/3Ph/60Hz

#### Options:

- D: Digital Scroll Compressor \*\*
- P: Programmable Timer
- Z: Zero-Loss Drain \*\*

\*\* Selections may not be available at time of print. Please contact Altec AIR for more information.

## 5.4 Technical Specifications

### 5.4.1 Air Dryer Conditions Information

	RAD-0025 through RAD-0200	RAD-0250 through RAD-2000	RHT-0010 through RHT-0060	RHT- 0080 through RHT- 0120
Max Inlet Air Temperature (F)	140	140	200	200
Max Inlet Air Pressure (PSIG)	232	232	232	232
Min Ambient Air Temperature (F)	45	45	45	45
Max Ambient Air Temperature (F)	120	120	120	120
Min Refrigerant Pressure (PSIG)	150	181	150	181
Max Refrigerant Pressure (PSIG)	300	450	300	450
Suction pressure (PSIG)	30	70	30	70
Discharge pressure (PSIG)	115	225	115	225
Drain Port NPT	¼	¼	¼	¼

### 5.4.2 Air Dryer Electrical Information



#### **WARNING!**

To avoid electrical overload and shock hazard, incoming power to Air Dryer must be sized according to Air Dryer specifications – refer to Air Dryer Electrical Information in Section 5.4.2

Plug Types:



NEMA 5-15P



NEMA 5-20P



RAD & RHT Model Electrical Information								
Model	Voltage	RLA	LRA	MCA	MOP	HP	Charge (oz)	Cord/Plug Type
<b>RAD-0025-1</b>	115V-1Ph-60Hz	3.7	29	6.2	15	1/5	9	NEMA 5-15P
<b>RHT-0010-1</b>								
<b>RAD-0040-1</b>	115V-1Ph-60Hz	3.7	29	6.2	15	1/5	9	NEMA 5-15P
<b>RHT-0015-1</b>								
<b>RAD-0055-1</b>	115V-1Ph-60Hz	4.9	28	8.4	15	1/4	9	NEMA 5-15P
<b>RHT-0020-1</b>								
<b>RAD-0075-1</b>	115V-1Ph-60Hz	5.8	32	9.8	15	1/3	9	NEMA 5-15P
<b>RHT-0030-1</b>								
<b>RAD-0075-2</b>	230V-1Ph-60Hz	3.0	16	5.2	15	1/3	9	Cord Only
<b>RHT-0030-2</b>								
<b>RAD-0100-1</b>	115V-1Ph-60Hz	9.5	48	15.4	25	1/2	12	NEMA 5-15P
<b>RHT-0040-1</b>								
<b>RAD-0100-2</b>	230V-1Ph-60Hz	4.8	23	7.9	15	1/2	12	Cord Only
<b>RHT-0040-2</b>								
<b>RAD-0150-1</b>	115V-1Ph-60Hz	13.6	56	21.4	35	3/4	15	NEMA 5-20P
<b>RHT-0060-1</b>								
<b>RAD-0150-2</b>	230V-1Ph-60Hz	7.3	38	12.0	20	3/4	15	Cord Only
<b>RHT-0060-2</b>								
<b>RAD-0200-1</b>	115V-1Ph-60Hz	13.6	78	24.3	40	1-1/4	24	NEMA 5-20P
<b>RHT-0080-1</b>								
<b>RAD-0200-2</b>	230V-1Ph-60Hz	11.8	37	19.4	30	1	24	Cord Only
<b>RHT-0080-2</b>								
<b>RAD-0250-3</b>	230V-3Ph-60Hz	6.0	38	5.8	15	1-1/4	37	No Cord or Plug
<b>RHT-0100-3</b>								
<b>RAD-0250-4</b>	460V-3Ph-60Hz	3.9	20	2.9	15	1-1/4	37	
<b>RHT-0100-4</b>								
<b>RAD-0250-5</b>	575V-3Ph-60Hz	3.1	16	2.3	15	1-1/4	37	
<b>RHT-0100-5</b>								
<b>RAD-0300-3</b>	230V-3Ph-60Hz	6.0	38	5.8	15	1-1/4	37	
<b>RHT-0120-3</b>								
<b>RAD-0300-4</b>	460V-3Ph-60Hz	3.9	20	2.9	15	1-1/4	37	
<b>RHT-0120-4</b>								
<b>RAD-0300-5</b>	575V-3Ph-60Hz	3.1	16	2.3	15	1-1/4	37	
<b>RHT-0120-5</b>								
<b>RAD-0400-3</b>	230V-3Ph-60Hz	10.3	55	10.0	25	3-1/2	80	
<b>RAD-0400-4</b>	460V-3Ph-60Hz	6.0	27	5.0	15	3-1/2	80	
<b>RAD-0400-5</b>	575V-3Ph-60Hz	4.8	22	4.0	15	3-1/2	80	
<b>RAD-0500-3</b>	230V-3Ph-60Hz	10.3	55	10.0	25	3-1/2	88	
<b>RAD-0500-4</b>	460V-3Ph-60Hz	6.0	27	5.0	15	3-1/2	88	

<b>RAD-0500-5</b>	575V-3Ph-60Hz	4.8	22	4.0	15	3-1/2	88	No Cord or Plug
<b>RAD-0600-3</b>	230V-3Ph-60Hz	11.4	55	11.6	30	3-1/2	96	
<b>RAD-0600-4</b>	460V-3Ph-60Hz	6.0	31	5.8	15	3-1/2	96	
<b>RAD-0600-5</b>	575V-3Ph-60Hz	4.8	25	4.7	15	3-1/2	96	
<b>RAD-0750-4</b>	460V-3Ph-60Hz	8.0	39	6.1	20	4-1/2	144	
<b>RAD-0750-5</b>	575V-3Ph-60Hz	6.4	31	4.9	15	4-1/2	144	
<b>RAD-1000-4</b>	460V-3Ph-60Hz	10.1	50	9.2	25	6	144	
<b>RAD-1000-5</b>	575V-3Ph-60Hz	8.1	40	7.3	20	6	144	
<b>RAD-1250-4</b>	460V-3Ph-60Hz	11.5	63	11.7	30	7	160	
<b>RAD-1250-5</b>	575V-3Ph-60Hz	9.2	50	9.4	25	7	160	
<b>RAD-1500-4</b>	460V-3Ph-60Hz	20.2	95	18.5	50	12	288	
<b>RAD-1500-5</b>	575V-3Ph-60Hz	16.2	76	14.8	40	12	288	
<b>RAD-2000-4</b>	460V-3Ph-60Hz	28.1	150	30.9	80	20	288	
<b>RAD-2000-5</b>	575V-3Ph-60Hz	22.5	120	24.7	65	20	288	

<b>"-D" Digital Scroll Model Electrical Information</b>								
<b>Model</b>	<b>Voltage</b>	<b>RLA</b>	<b>LRA</b>	<b>MCA</b>	<b>MOP</b>	<b>HP</b>	<b>Charge (oz)</b>	<b>Cord/Plug Type</b>
<b>RAD-0400-3-D</b>	230V-3Ph-60Hz	14.0	77	13.4	40	4-1/2	80	No Cord or Plug
<b>RAD-0400-4-D</b>	460V-3Ph-60Hz	8.1	39	7.1	20	4-1/2	80	
<b>RAD-0400-5-D</b>	575V-3Ph-60Hz	6.5	31	5.6	15	4-1/2	80	
<b>RAD-0500-3-D</b>	230V-3Ph-60Hz	14.0	77	14.1	40	4-1/2	88	
<b>RAD-0500-4-D</b>	460V-3Ph-60Hz	8.1	39	7.1	20	4-1/2	88	
<b>RAD-0500-5-D</b>	575V-3Ph-60Hz	6.5	31	5.6	15	4-1/2	88	
<b>RAD-0600-3-D</b>	230V-3Ph-60Hz	14.0	77	14.1	40	4-1/2	96	
<b>RAD-0600-4-D</b>	460V-3Ph-60Hz	8.1	39	7.1	20	4-1/2	96	
<b>RAD-0600-5-D</b>	575V-3Ph-60Hz	6.5	31	5.6	15	4-1/2	96	
<b>RAD-0750-4-D</b>	460V-3Ph-60Hz	9.0	39	7.1	20	4-1/2	144	
<b>RAD-0750-5-D</b>	575V-3Ph-60Hz	7.2	31	5.6	15	4-1/2	144	
<b>RAD-1000-4-D</b>	460V-3Ph-60Hz	9.3	48	9.5	25	6	144	
<b>RAD-1000-5-D</b>	575V-3Ph-60Hz	7.4	38	7.6	20	6	144	
<b>RAD-1250-4-D</b>	460V-3Ph-60Hz	11.9	75	13.6	30	8	160	
<b>RAD-1250-5-D</b>	575V-3Ph-60Hz	9.5	60	10.9	25	8	160	
<b>RAD-1500-4-D</b>	460V-3Ph-60Hz	19	99	18.2	50	12	288	
<b>RAD-1500-5-D</b>	575V-3Ph-60Hz	15.2	79.2	14.6	40	12	288	
<b>RAD-2000-4-D</b>	460V-3Ph-60Hz	24.5	125	25.8	70	17	288	
<b>RAD-2000-5-D</b>	575V-3Ph-60Hz	19.6	100	20.6	55	17	288	

RLA: Rated Load Amps – maximum current the Air Dryer should draw from the supply under any operating conditions.

LRA: Locked-Rotor Amperage – The highest current the Air Dryer draws from the supply when power is first applied

MCA: Minimum Circuit Amps – Highest steady-state electrical current

MOP: Maximum Over-Current Protection – Maximum size of over-current protection device such as circuit breakers or fuses

*NOTE: “-5” Air Dryer models may utilize an internal power transformer to accommodate 575V-3Ph-60Hz supply voltage. The product’s data label reflects loads and ratings for the incoming electrical supply.*

### 5.4.3 RAD Series Correction Factors

Corrected Inlet Flow Capacity =

$$\text{INLET Flow (above)} \times \text{Inlet Pressure Correction Factor (A)} \times \text{Inlet Temp Correction Factor (B)} \times \text{Ambient Temp Correction Factor (C)}$$

Inlet Pressure (PSIG)	50	80	100	125	150	175	200
Correction Factor (A)	0.82	0.95	1.00	1.05	1.09	1.12	1.15
Inlet Temp (°F)	80	90	100	110	120	140	
Correction Factor (B)	1.72	1.28	1.00	0.80	0.66	0.45	
Ambient Temp (°F)	80	90	100	110	120		
Correction Factor (C)	1.08	1.06	1.00	0.90	0.76		

### 5.4.4 RHT Series Correction Factors

Corrected Inlet Flow Capacity =

$$\text{INLET Flow (above)} \times \text{Inlet Pressure Correction Factor (A)} \times \text{Inlet Temp Correction Factor (B)} \times \text{Ambient Temp Correction Factor (C)}$$

Inlet Pressure (PSIG)	100	125	150	175	200
Correction Factor (A)	0.80	0.88	0.95	1.00	1.04
Inlet Temp (°F)	100	125	150	180	200
Correction Factor (B)	3.31	1.99	1.30	1.00	0.91
Ambient Temp (°F)	80	90	100	110	120
Correction Factor (C)	1.08	1.06	1.00	0.90	0.76

## 5.5 Air Dryer Function Overview

### 5.5.1 Functional Flow Diagram RAD-0025 through RAD-0055, RHT-0010 through RHT-0020

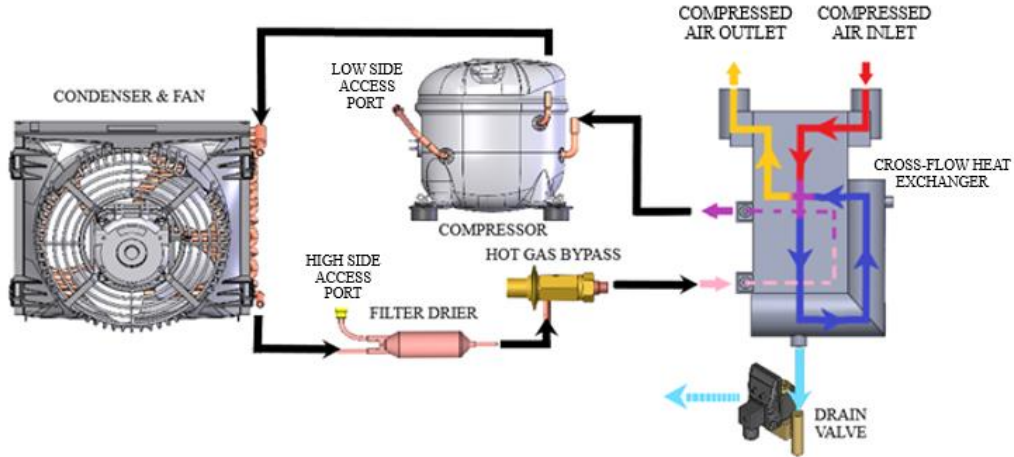

### 5.5.2 Functional Flow Diagram RAD-0075 through RAD-0200, RHT-0030 through RHT-0080

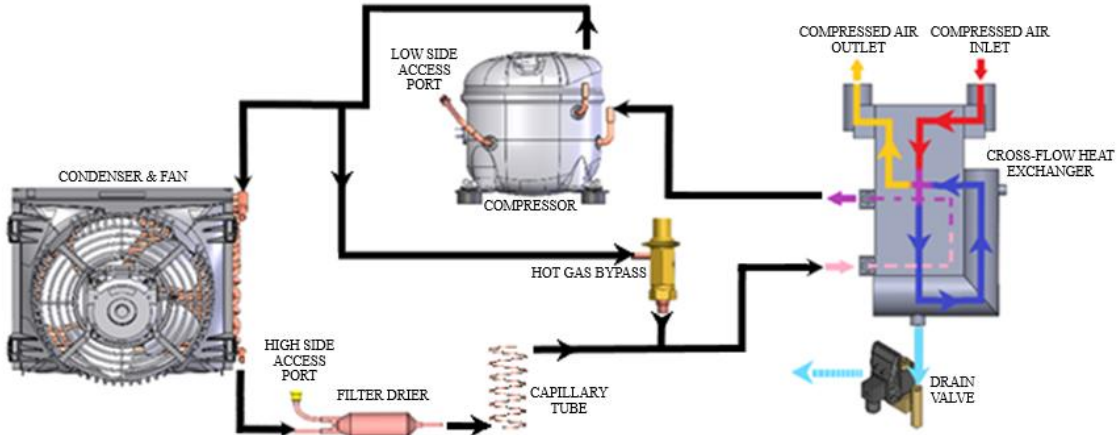

**5.5.3 Functional Flow Diagram RAD-0250 through RAD-0300, RHT-0100 through RHT-0120**

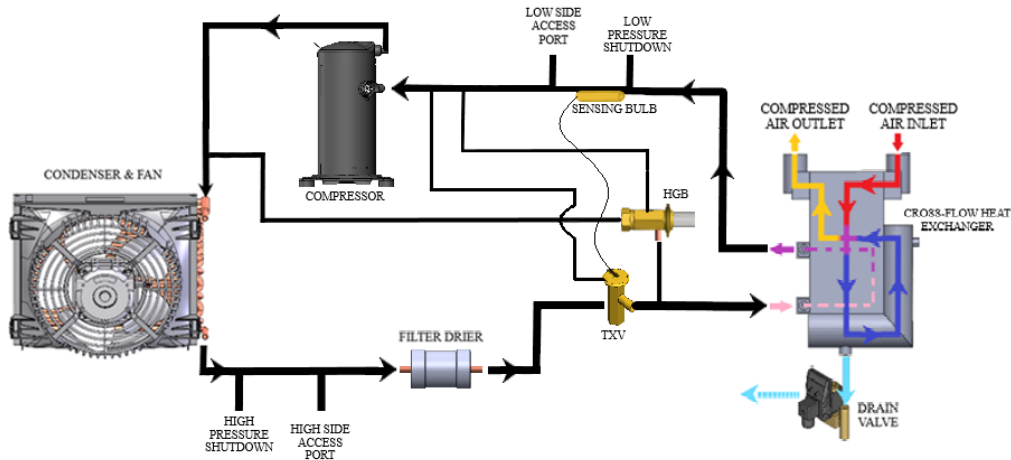

**5.5.4 Functional Flow Diagram RAD-0400 through RAD-1250**

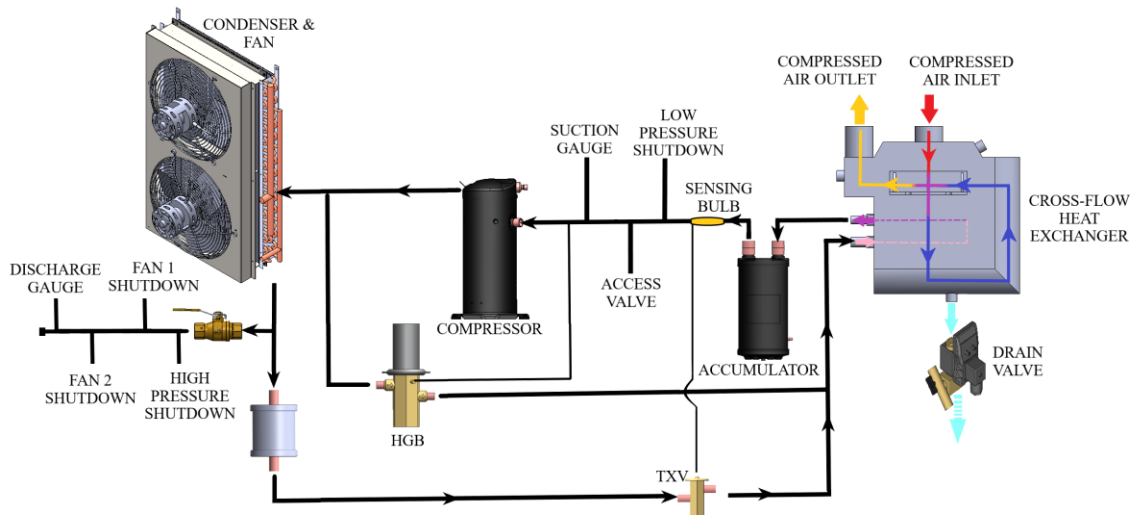

Component	Description
<b>Accumulator</b>	Prevents liquid refrigerant from entering the compressor
<b>Condenser &amp; Fan</b>	Cools the hot gas from the compressor into a liquid
<b>Compressor</b>	Draws in refrigerant and compresses it to a gas
<b>Cross-flow Heat Exchanger</b>	Exchanges thermal energy from the air to the refrigerant
<b>Access Port</b>	Ports for adding or removing refrigerant and for refrigerant gauges
<b>Filter Drier</b>	Filters out any particulates in the refrigerant
<b>Hot Gas Bypass (HGB)</b>	Regulates the cooling temperature based on refrigerant pressure
<b>Drain Valve</b>	Drain for condensed water removed from the air in the heat exchanger
<b>Thermostatic Expansion Valve (TXV)</b>	Regulates the rate liquid refrigerant flows into the evaporator

## 6. Installing Your Air Dryer

### 6.1 Safety & Warning Information



#### **WARNING!**

This appliance is not intended for use by persons (including children) with reduced physical, sensory, or mental capabilities, or lack of experience and knowledge, unless they have been given supervision or instruction concerning use of the appliance by a person responsible for their safety.



#### **WARNING!**

Children must be supervised to ensure that they do not play with the appliance.



#### **WARNING!**

To avoid electrical shock, damaged cords should be replaced by a qualified individual



#### **WARNING!**

To avoid electrical overload and shock hazard, incoming power to Air Dryer must be sized according to Air Dryer specifications – refer to Air Dryer Electrical Information in Section 5.4.2

## 6.2 Before You Begin

The Air Dryer cannot be tilted on its side or upside-down during shipping.

Upon arrival check the Air Dryer for damage. Inspect the pressure gauge through the box cutout and ensure the gauge does not read zero. Review data label and ensure proper electrical circuit to support voltage and amperage of the Air Dryer.

The Air Dryer must be installed in a well-ventilated room that is free from dust, toxic gases, humidity, or pollution. Ambient temperatures must be at least 45° F and not exceed 120°F.

All Air Dryers are designed to be installed on a concrete base capable of supporting the weight and forces from the Air Dryer operation. Install the Air Dryer by removing the Air Dryer from the shipping pallet.

Air Dryers must be installed at least three feet away from walls and any other equipment or walls.

Do not run air through the Air Dryer without power to the unit on.

Do not mix inlet and outlet air flow. Pipe diameter should be sized according to the air flow requirement of the Air Dryer. Do not use the inlet and outlet of the Air Dryer to support the weight of the air piping.

A complete compressed air filter kit is recommended to protect your Air Dryer and downstream processes from contaminants found in the compressed air supply. Oil and particulates can damage the heat exchanger and reduce the Air Dryer efficiency.

A bypass may also be installed on the Air Dryer outlet, inlet and filtration to allow for bypassing, depressurizing, maintenance, and servicing of the Air Dryer.

Tubing used must be secured as the condensate is discharged at the system pressure. Connect the condensate drain port to a collection point and dispose of condensate in compliance to local regulations. Condensate may contain oil particles from the compressor air.

Consult with a licensed technician to ensure the electrical network and protection is sized properly. Ensure all fuses or breakers are correctly sized based on the data label information. For electrical data refer to Section 5.4.2

Prior to connecting the Air Dryer to the electrical supply, verify the data nameplate for the proper electrical information.

Air Dryers are equipped with either a power cord or terminal hookup locations. Refer to Section 5.4.2 for plug type. Do not use any socket adapters at the main plug.

Air Dryers without a power cord included must be wired by a licensed technician according to the model specific wiring diagram as shown in Section 13.1 .

If your unit is equipped with a programmable timer (Option -P), please refer to the programming your timer section [13.2.1](#), prior to operating your unit.



### 6.3 Installation Configuration

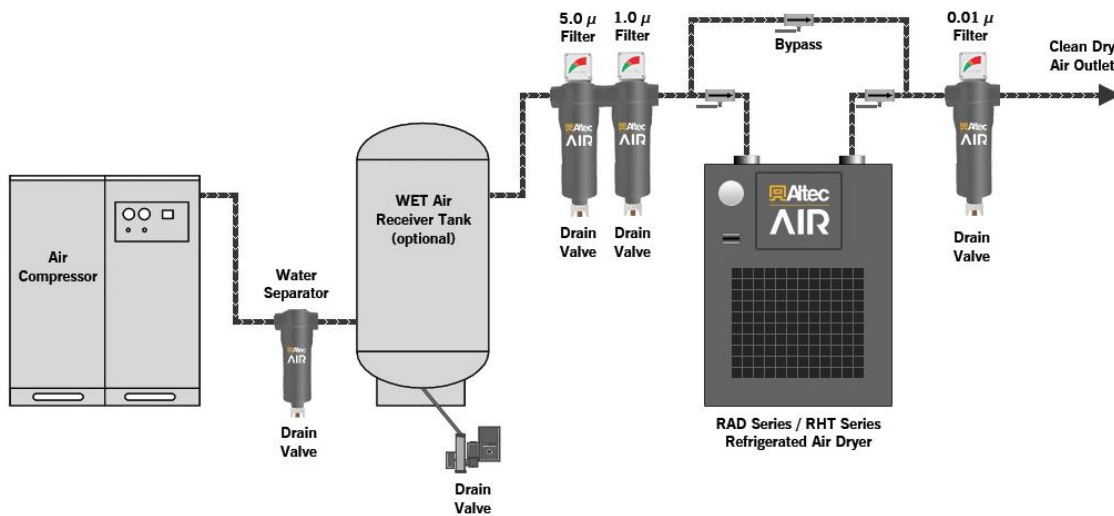

Figure 1: Wet Air Receiver Tank Set-Up

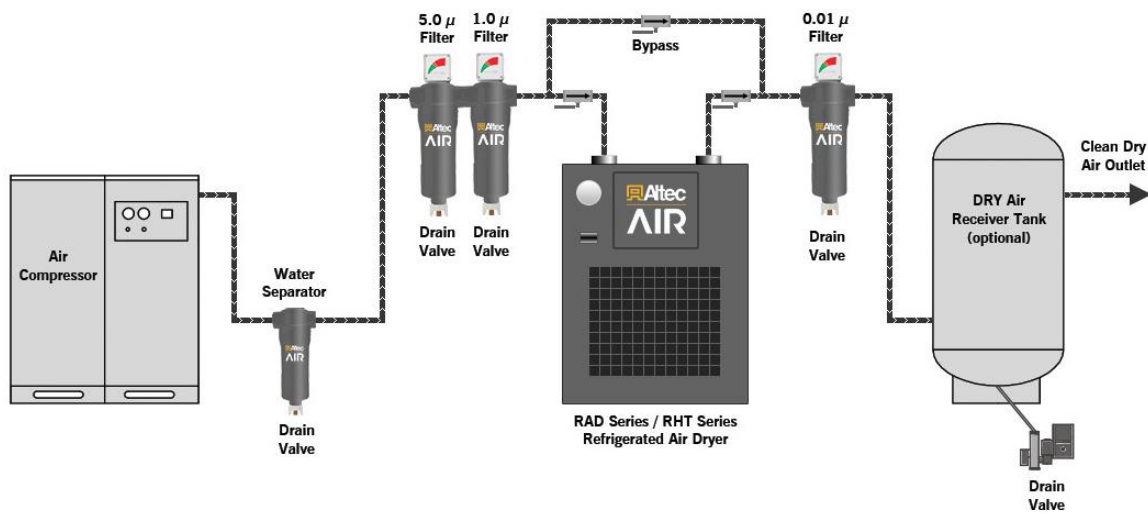

Figure 2: Dry Air Receiver Tank Set-Up

Wet Air Receiver Tank Set-Up: Recommended for systems that consume less than or equal to the maximum capacity of the air compressor

Dry Air Receiver Tank Set-up: Recommended for systems where the peak air consumption exceeds the flow rate of the air compressor. The tank capacity must be sized to compensate for the peak demand.

## 6.4 Included Contents

Items included with the Air Dryer:

- (1) Refrigerated Air Dryer
- (1) User's Guide
- (4) Latch Keys RAD-0075 through RAD-1250, RHT-0030 through RHT-0120

## 6.5 Required Tools and Materials

- Medium adjustable wrench
- Box cutter
- Cup of soapy water
- 1-inch paint brush (recommended)

## 6.6 Installation Steps

**6.6.1** Use a box cutter to remove the Air Dryer from the box and shipping materials

**NOTE:** If ANY SHIPPING DAMAGE is detected, file a claim with the shipping company prior to continuing the installation process.

**6.6.2** Open Panel Latches and remove one of the Side Panels

**6.6.3** Check for loose parts, hoses, wiring, and copper tubing for leaks for cracks

**6.6.4** Place the Air Dryer at the desired operating location:

- Place the Air Dryer on a leveled surface
- Ensure Air Dryer is at least three feet away in all directions from other equipment or walls

**6.6.5** Remove the plugs from the Inlet and Outlet Air Ports

- 6.6.6** Install plumbing from the Inlet and the Outlet of the Air Dryer to the proper air compressor setup
- 6.6.7** Route the Condensate Drain Line to an environmentally approved disposal system per local regulations.
- 6.6.8** Verify that the Air Dryer is powered OFF
- 6.6.9** Verify the main electrical supply voltage matches the voltage on the Data Label and that proper circuit protection has been installed.
- 6.6.10** Plug AC Power Cord to Air Dryer or have a qualified individual wire the correct power to the Air Dryer in accordance to local, state, regional, or territory codes and requirements.
- 6.6.10.1** If equipped with a programable timer, see section [13.2.1](#)
- 6.6.11** Power the Air Dryer ON
- 6.6.12** Use the soapy water and paint brush to check for leaks in the Air Inlet and Outlet plumbing
- 6.6.13** Allow the Air Dryer to operate for 15 minutes
- 6.6.14** Verify the Refrigerant Suction Pressure
- R134a Air Dryers: 28-34 PSIG\*
  - R404a Air Dryers: 72-80 PSIG\*
  - R449a Air Dryers: 55-85 PSIG\*
- 6.6.15** Verify the Refrigerant Discharge Pressure (RAD-0250 and larger)
- R449a Air Dryers: 110-275 PSIG\*

\*Pressure will vary depending on operating and ambient conditions

- 6.6.16** Verify the Condenser Fan Motors are operating
- Fan 1 R449a Dryers: On at 250 PSIG, Off at 200 PSIG
  - Fan 2 R449a Dryers: On at 300 PSIG, Off at 250 PSIG
- 6.6.17** Confirm that condensate is discharging from the Condensate Drain based on Drain Valve time settings
- 6.6.18** Confirm that the Condensate Drain tubing is clear of obstructions
- 6.6.19** Check the Dew Point of the outlet air
- 6.6.20** Hook up Refrigerant Gauges
- 6.6.21** Check the Evaporating Pressure, Suction and Discharge Pressure
- 6.6.22** Use the wrench to adjust the Hot Gas Bypass a quarter turn at a time to dial in the Evaporator Temperature to 33-35 degrees Fahrenheit
- After each quarter turn, allow Air Dryer to operate for 5 minutes
- 6.6.23** Reinstall the Side Panel
- 6.6.24** **REGISTER YOUR AIR DRYER.** *See section 7 for details.*

## 7. Registering Your Air Dryer

Please take a moment to register your Altec AIR Refrigerated Non-Cycling Series Air Dryer. Registering is necessary to activate the Limited Warranty on your product. Once you register, you are eligible to receive free technical support, as well as updates concerning your Altec AIR products.

Register Online at [www.altecair.com/product-support/registration/](http://www.altecair.com/product-support/registration/)

Or by Phone 1-800-521-5351 (option 2)

Have the following information available:

### **PRODUCT INFORMATION**

**Model #:** \_\_\_\_\_ **Serial #:** \_\_\_\_\_

**Date Purchased:** \_\_\_\_\_ **Date Installed:** \_\_\_\_\_

**Distributor Company Name** (if applicable): \_\_\_\_\_

**Customer Company Name:** \_\_\_\_\_

### **INSTALLATION LOCATION INFORMATION**

**Location Name** (if applicable): \_\_\_\_\_

**Street Address:** \_\_\_\_\_

**City:** \_\_\_\_\_ **State:** \_\_\_\_\_ **Zip Code:** \_\_\_\_\_

### **CONTACT INFORMATION**

**Contact Name:** \_\_\_\_\_ **Phone #:** ( ) - ext. \_\_\_\_\_

**Email:** \_\_\_\_\_

## 8. Operating Your Air Dryer

### 8.1 Air Dryer Access

**8.1.1** To remove Side Panel, unlock Latches using Latch Keys included with the Air Dryer. Press Latch down and pull outward and up. To replace Side Panel, line up bottom tab and tilt panel inward. Press Latches down and lock if needed.

**8.1.2** To remove the Top Panel, remove both Side Panels. Then locate the four screws on the top and remove. Lift Panel straight up and off the Air Dryer.

### 8.2 Refrigerant Manifold Attachment

**8.2.1** See Functional Flow Diagrams for High Side/Low Side ports – Section 5.5 Remove the low side and high side access valve caps. Connect the blue tube of the refrigerant manifold to the low side access valve. Connect the red tube of the refrigerant manifold to the high side access valve. Open refrigerant manifold valves on the high side and low side. Ensure correct refrigerant type is selected on the refrigeration manifold readout.



### 8.2.2 Important measurements to note:

- Evaporating temperature
- Low side pressure
- High side pressure



## 8.3 Drain Valve Operations

If your unit is equipped with the zero loss drain (Option -Z or -D), please refer to the operating your drain section [13.3](#).

**8.3.1** To manually open the Drain Valve, depress the ‘TEST’ Button.

**8.3.2** The Drain Valve Open (ON) Time is adjustable from 0.5 seconds to 10 seconds. The default setting is 6 seconds. When the Drain Valve opens, the ‘ON’ light will illuminate. To change the Open Time, twist the Knob labelled ‘ON-SEC’ to the desired time.

**8.3.3** The Drain Valve Closed (OFF) Time is adjustable from 0.5 minutes to 45 minutes. The default setting is 10 minutes. When the Drain Valve is closed, the ‘OFF’ light will illuminate. To change the Closed Time, twist the Knob labelled ‘OFF-MIN’ to the desired time.

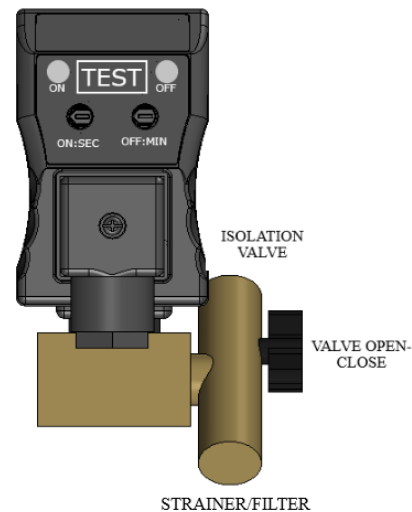

**8.3.4** To clean the Drain Valve, close the Isolation Valve. Depress the Test Button to release the pressure. Remove the Filter from the bottom of the Isolation

Valve by twisting off the threaded base and pulling out the Filter. Clean the Filter and replace. Open the Drain Valve and resume normal operation.

#### **8.4 Hot Gas Bypass Valve Adjustments (HGBV)**

**8.4.1** Attach refrigerant gauges to the Air Dryer.

**8.4.2** Allow Air Dryer to operate for 15 minutes after running under the compressed air load.

**8.4.3** Open the Side Panel that allows for the easiest access to the Hot Gas Bypass Valve.

**8.4.4** Remove the black rubber cap from the Hot Gas Bypass Valve.

**8.4.5** Take note of the initial Evaporating Temperature value shown on the refrigerant gauges.

**8.4.6** Turn the Hot Gas Bypass Valve hex head bolt one quarter turn.

**8.4.7** Allow the Air Dryer to operate 5 minutes.

**8.4.8** Note the new Evaporating Temperature.

**8.4.9** Continue to adjust the Hot Gas Bypass Valve until the Evaporating Temperature is between 32 and 34 degrees Fahrenheit.

**8.4.10** Replace the black rubber cap, remove the refrigerant gauges, and replace the Air Dryer Side Panel.





## 8.5 Thermostatic Expansion Valve Adjustments (TXV)

**8.5.1** The TXV controls the amount of superheat. To adjust, use a wrench to turn the hex nut one quarter turn at a time.

**8.5.2** Allow Air Dryer to operate for 5 minutes prior to adjusting further.



## 8.6 Condenser Coil Cleaning

**8.6.1** Open both Side Panels of the Air Dryer and Top Panel if necessary to reach the Condenser Coil.

**8.6.2** Blow clean pressurized air into the fins of the Condenser Coils from the front and top as accessible. Do not bend fins in the process.

**8.6.3** Replace Air Dryer Panels.

## 9. Maintaining Your Air Dryer

To ensure that your Refrigerated Non-Cycling Series Air Dryer continues to operate efficiently and reliably, Altec AIR recommends performing the following maintenance procedures at the specified time intervals.

## 9.1 Safety & Warning Information



### **WARNING!**

**Extreme care should be exercised to avoid contact with live electrical circuits.** Many procedures performed during installation, operation, testing, and maintenance of this Air Dryer require the equipment to be running, creating a situation for potential electrical shock. It is highly recommended that you remove all jewelry before performing any procedures.



### **CAUTION!**

**Internal surfaces may be hot.** Use care when coming into contact with internal components as there is a potential for some of these components to become hot when in operation or standby.



### **CAUTION!**

Depressurizing the Air Dryer may be necessary before performing certain procedures.

### **NOTICE!**

Air Dryer failure due to a dirty Condenser is not covered under warranty.

## 9.2 Regular Maintenance

Time Frame	Maintenance Operation	Reference Section
Weekly	Check Automatic Drain Valve operation once per eight-hour shift	8.3.1
	Ensure Suction Pressure Gauge in proper range	6.6.14
	Ensure Condenser Coil is clean and unobstructed	8.6

	Clean air-cooled Condenser Coils	8.6
Monthly	Clean Automatic Drain Valve	8.3.4
	Check Compressed Air Filter Differential	Refer to Filter manufacturer
	Replace Pre and Post Filtration Elements	Refer to Filter manufacturer

## 10. Troubleshooting Your Air Dryer

### 10.1 Before You Call Altec AIR

**PLEASE READ THIS SECTION FIRST.** It is important that you use the following sections in order to diagnose and attempt to fix the problem with your Air Dryer before placing a call to Altec AIR Technical Support.

This troubleshooting guide is intended to simplify the isolation of problems, present possible causes, provide test procedures for verification, and suggest corrective actions to restore the Air Dryer back to normal operation. Each section begins with the most likely cause(s) of the issue. Otherwise, they start from the simplest possibilities and progress to more complicated ones.

This troubleshooting guide is designed to be easy to follow and very effective when used properly. It is suggested to always start at the beginning of the specific problem section and continue in sequence, following the procedures indicated.

## 10.2 Safety & Warning Information



### **WARNING!**

**For your safety, all the information in this User's Guide must be followed to minimize the risk of electrical shock, and prevent property damage or personal injury.**



### **WARNING!**

**Internal surfaces may be hot.** Use care when coming into contact with internal components as there is a potential for some of these components to become hot when in operation or standby.



### **WARNING!**

**Extreme care should be exercised to avoid contact with live electrical circuits.** Many procedures performed during installation, operation, testing, and maintenance of this Air Dryer require the equipment to be running, creating a situation for potential electrical shock. It is highly recommended that you remove all jewelry before performing any procedures.



### **CAUTION!**

Depressurizing the Air Dryer may be necessary before performing certain procedures.

**NOTICE!**

Performing routine maintenance as outlined in the *Maintaining Your Dryer* section will ensure optimal performance over the lifecycle of your Air Dryer. Performing procedures not recommended by Altec AIR or installing components not supplied by Altec AIR is NOT RECOMMENDED AND MAY VOID THE WARRANTY.

**10.3 Air Dryer Not Performing – High Outlet Dew Point**

Possible Cause	Check	Correction
Air Compressor too hot	Verify Cooler on Air Compressor working	Fix Air Compressor to supply proper inlet air flow
Condenser Coils Dirty	Verify Condenser Fins are clean and unobstructed	Using clean compressed air or a dry soft cloth clean any dust or debris from the Condenser Fins
Fan not Running Correctly	Verify the Fan Blade is spinning and that air is blown from the outside of the Air Dryer towards the inside of the Air Dryer	Rewire according to Wiring diagram
Incorrectly sized Air Dryer	Verify the inlet air conditions and the Air Dryer ratings	Consult Altec AIR for assistance with properly sizing your Air Dryer

**10.4 Condensate in Piping After Air Dryer**

Possible Cause	Check	Correction
Air Dryer operating outside of its rating	Verify the inlet air conditions and the Air Dryer ratings	Supply Air Dryer with rated inlet and ambient air
Condensate Drain Not Working	Press the TEST Button on the Drain Valve	Clean Filter
Inlet Air Contains Liquid Water	Verify inlet air is free from liquid	Add in a Condensate Filter prior to the Air Dryer Inlet

## 10.5 Contacting Altec AIR Technical Support

**Please read the *Before You Call Altec AIR* section (10.1 10.1 )**

Once you have exhausted all the potential problems and solutions covered in the *Troubleshooting Your Air Dryer* section, and you still require further assistance to correct a problem, contact Altec AIR Technical Support:

(800) 521-5351 (option 1)

Have the following information available:

**Trouble Ticket # (if following-up on a previous call):** \_\_\_\_\_  
**Technician Name:** \_\_\_\_\_ **Phone #:** \_\_\_\_\_  
**Model #:** \_\_\_\_\_ **Serial #:** \_\_\_\_\_  
**Company Name:** \_\_\_\_\_ **Location Name:** \_\_\_\_\_  
**City:** \_\_\_\_\_ **State:** \_\_\_\_\_

## 11. Replacement Parts & Accessories

### 11.1 Air Dryer Diagram, Image, Explosion w/ Part List

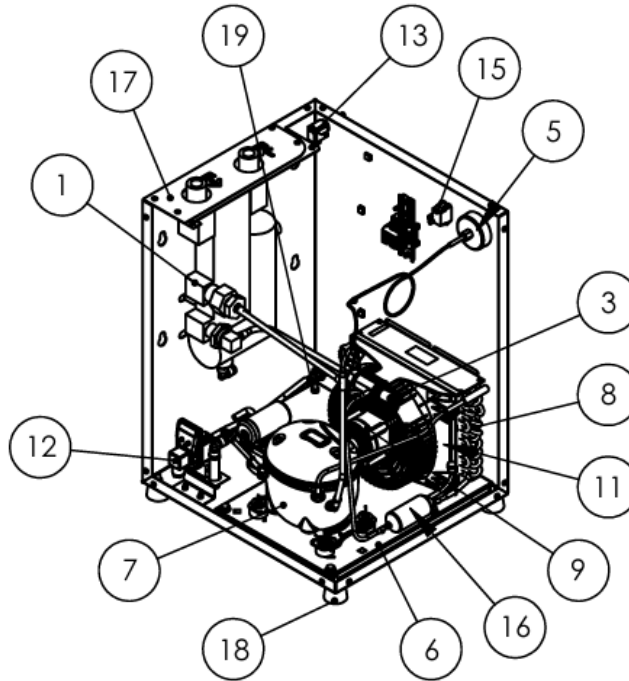

RAD-0025 through RAD-0055 and RHT-0010 through RHT-0020

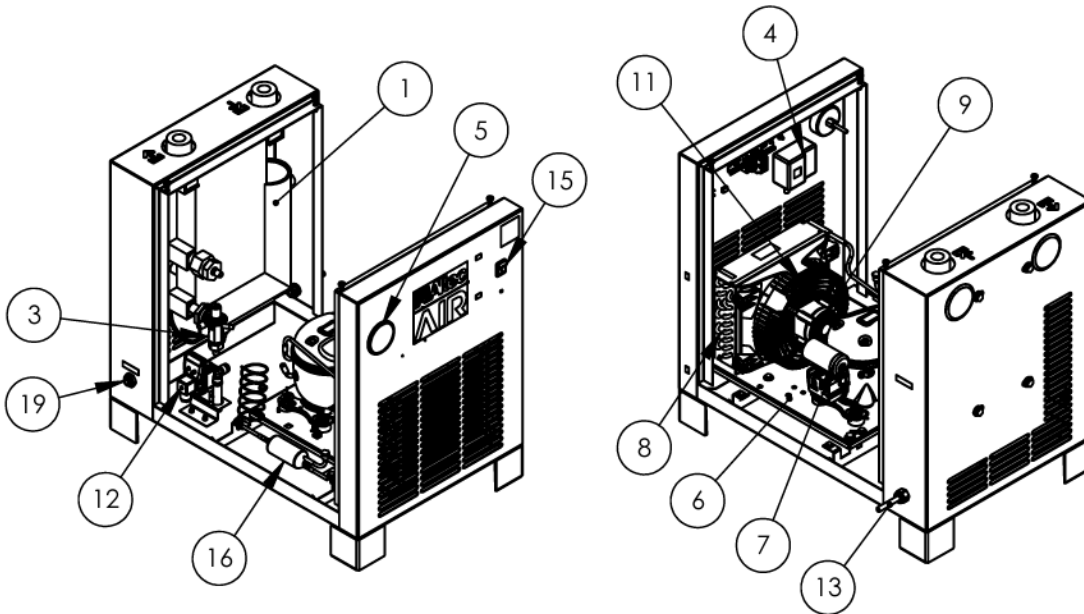

RAD-0075 through RAD-0200 and RHT-0030 through RHT-0080

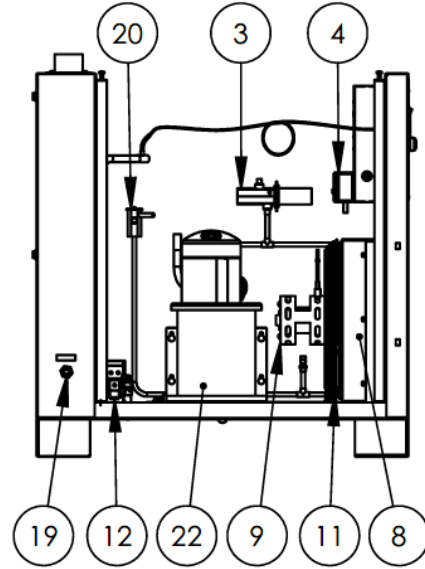
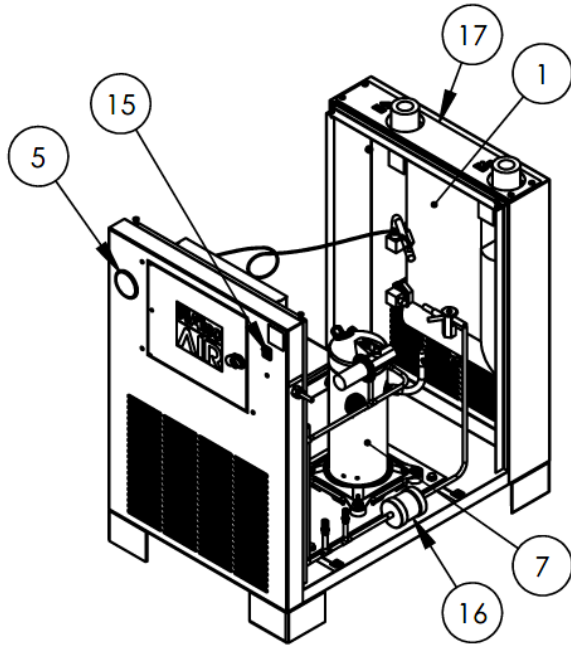

RAD-0250 through RAD-0300 and RHT-0100 through RHT-0120

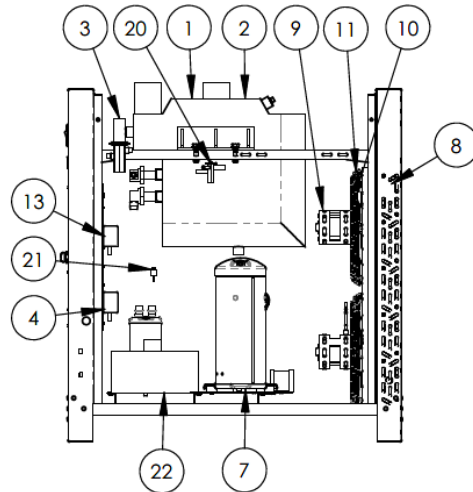
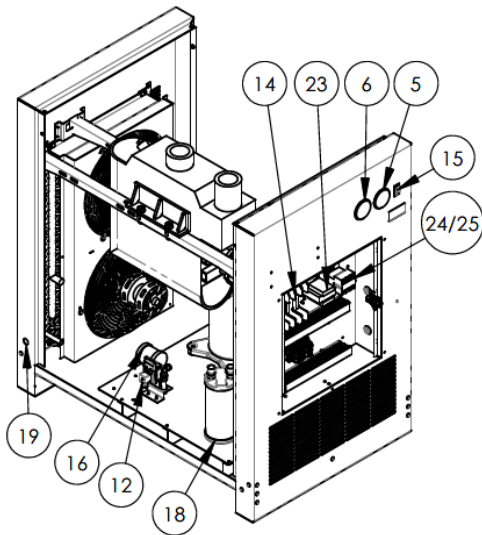

RAD-0400 through RAD-2000



11.1.1 Single Phase Units Replacement Parts

Ref#	Description	PN	RAD-0025A-1	RAD-0040A-1	RAD-0055A-1	RAD-0075A-1	RAD-0075A-2	RAD-0100A-1	RAD-0100A-2	RAD-0150A-1	RAD-0150A-2	RAD-0200A-1	RAD-0200A-2	
1	Heat Exchanger Assembly	100514889	X											
		100514875		X	X									
		100514891				X	X	X	X					
		100514898									X	X	X	
		100521723												X
2	Heat Exchanger	100513579	X											
		100513571		X	X									
		100513568				X	X	X	X					
		100513569									X	X	X	X
3	Hot Gas Bypass	100513518	X	X	X									
		100513519				X	X	X	X	X	X			
		100513276											X	X
4	High Pressure Shutdown	100513517				X	X	X	X	X	X	X	X	
5	Suction Pressure Gauge	100511199	X	X	X	X	X	X	X	X	X	X	X	
6	Condensing Unit	100514868	X	X										
		100510803			X									
		100510802				X								
		100514867					X							
		100510792						X						
		100510794							X					
		100510796								X				
		100510797									X			
		100514881										X		
		100510763											X	
7	Compressor	100518790	X	X										
		100510955			X									
		100510956				X								
		100518795					X							
		100510933						X						
		100518800							X					
		100510971								X				
		100514452									X			
		NOTE 1											X	
		100514806												X
8	Condensing Coil	100518791	X	X										
		100514455			X	X								
		100518796					X							
		100514456						X						
		100518801							X					
		100514457								X	X			
		NOTE 1											X	
100514807												X		

Ref#	Description	PN	RAD-0025A-1	RAD-0040A-1	RAD-0055A-1	RAD-0075A-1	RAD-0075A-2	RAD-0100A-1	RAD-0100A-2	RAD-0150A-1	RAD-0150A-2	RAD-0200A-1	RAD-0200A-2	
9	Fan Motor	100518792	X	X										
		100510926			X	X								
		100518797					X							
		100510873						X						
		100518802							X					
		100510874								X				
		100510838									X			
		NOTE 1											X	
100510840												X		
10	Fan Blade	100518793	X	X										
		100514462			X									
		100514460				X								
		100518798					X							
		100514463						X						
		100518803							X					
		100510893								X	X		X	
		NOTE 1											X	
11	Fan Guard	100518794	X	X										
		100514465			X									
		100510885				X								
		100518799					X							
		100514466						X						
		100518804							X					
		100514472								X	X			
		NOTE 1											X	
		100514809												X
12	Drain Valve	100513116	X	X	X	X		X		X		X		
		100513117					X		X		X		X	
13	Power Cord	100518728	X	X	X	X	X	X	X				X	
		100520958								X	X	X		
14	Power Plug	100512710								X		X		
15	Power switch	100514964	X	X	X	X	X	X	X	X	X	X	X	
16	Filter Drier	100513398	X	X	X	X	X	X	X	X	X			
		100513377											X	X
17	HE Cover Plate	100514911	X											
		100514912		X	X									
18	Rubber Foot	100516244	X	X	X									
19	Drain Bulkhead	100518729	X	X	X	X	X	X	X	X	X	X	X	

NOTE 1: Call Altec AIR for replacement part number

11.1.2 Three Phase Units Replacement Parts

Ref. #	Description	PN	RAD-0250A-3	RAD-0250A-4	RAD-0250A-5	RAD-0300A-3	RAD-0300A-4	RAD-0300A-5	RAD-0400A-3	RAD-0400A-4	RAD-0400A-5	RAD-0500A-3	RAD-0500A-4	RAD-0500A-5	RAD-0600A-3	RAD-0600A-4	RAD-0600A-5	RAD-0750A-4	RAD-0750A-5	RAD-1000A-4	RAD-1000A-5	RAD-1250A-4	RAD-1250A-5	RAD-1500A-4	RAD-1500A-5	RAD-2000A-4	RAD-2000A-5		
1	Heat Exchanger Assembly	100515026	X	X	X																								
		100515033				X	X	X																					
		100520385							X	X	X																		
		100520388											X	X	X														
		100520375														X	X	X											
		100520497																		X	X								
		100520632																				X	X						
		100520633																						X	X				
3	Hot Gas Bypass	100513276	X	X	X	X	X	X																					
		100513384							X	X	X	X	X	X	X	X	X	X											
		100513272																								X	X	X	X
4	High Pressure Shutdown	100513517	X	X	X	X	X	X	X	X	X	X	X	X	X	X	X	X	X	X	X	X	X	X	X	X	X	X	
5	Suction Pressure Gauge	100511200	X	X	X	X	X	X	X	X	X	X	X	X	X	X	X							X	X	X	X		
6	Discharge Pressure Gauge	100511197							X	X	X	X	X	X	X	X	X	X	X	X	X	X	X	X	X	X	X		
7	Compressor	100521022	X			X																							
		100521026		X	X		X	X																					
		100520344							X			X																	
		100520412								X	X		X	X															
		100520413														X													
		100520335														X	X												
		100520486																	X	X									
		100520634																				X	X						
		100520487																						X	X				
		100511817																								X	X		
		100511818																									X	X	
8	Condensing Coil	100510819	X	X	X	X	X	X																					
		100514561							X	X	X	X	X	X	X	X	X												
		100520501																	X	X	X	X	X	X					
		100510848	X	X	X	X	X	X				X				X													
		100510818																								X	X	X	X
		100510839								X	X		X	X		X	X												
10	Fan Blade	100510825	X	X	X	X	X	X	X	X	X	X	X	X	X	X	X												
		100510821																							X	X	X	X	
11	Fan Guard	100514467	X	X	X	X	X	X																					
		100510834							X	X	X	X	X	X	X	X	X												
		100510835																							X	X	X	X	

12	Drain Valve	100513116	X	X	X	X	X	X	X	X	X	X	X	X	X	X	X	X	X	X					
		100513117	X		X		X		X		X		X		X		X		X		X		X	X	X
		100513119																		X	X	X	X		
13	Fan Switch	100513516				X	X	X	X	X	X	X	X	X	X	X	X	X	X	X	X	X	X	X	
14	Fuse Block	100512189						X		X		X		X		X		X		X		X	X		
15	Power Switch	100514964	X	X	X	X	X	X	X	X	X	X	X	X	X	X	X	X	X	X	X				
		100513264																		X	X	X	X		
16	Filter Drier	100513377	X	X	X	X	X																		
		100513379					X	X	X	X	X	X	X	X											
		100513381																			X	X	X	X	
17	HE Cover Plate	100514830	X	X	X																				
		100514602			X	X	X																		
18	Accumulator	100513169				X	X	X	X	X	X	X	X	X											
		100513174												X	X	X	X	X	X						
		100513171																		X	X	X	X		
19	Drain Bulkhead	100518729	X	X	X	X	X	X																	
		NOTE 1				X	X	X	X	X	X	X	X	X	X	X	X	X	X	X	X	X	X	X	X
20	Thermostatic Expansion Valve	100520504	X	X	X	X	X	X	X																
		100520456								X	X	X	X	X											
		100520502												X	X										
		100520503														X	X	X	X						
		100513514																		X	X				
		100513515																					X	X	
21	Low Pressure Shutdown	100513395	X	X	X	X	X	X	X	X	X	X	X	X	X	X	X	X	X	X	X	X	X	X	
22	Transformer 460/575 VAC	100512862		X		X																			
		100512863					X		X		X														
		100512866											X		X		X								
		NOTE 1																		X	X	X	X		
23	Transformer 230/460 VAC	100513138	X	X	X	X	X	X	X	X	X	X	X	X	X	X	X	X	X	X					
		NOTE 1																		X	X	X	X		
24	Contactor 120 VAC	100510862	X	X	X	X	X	X	X	X	X	X	X	X	X	X	X	X	X	X	X				
		NOTE 1																				X	X		
25	Contactor 230 VAC	100510861	X		X		X		X		X														

NOTE 1: Call Altec AIR for replacement part number

## 11.2 Accessories

### 11.2.1 Floor Stands

Model	Use With Air Dryer
<b>AFS-1</b>	RAD-0025A – RAD-0055A RHT-0010 – RHT-0020
<b>AFS-2</b>	RAD-0075A – RAD-0100A RHT-0030 – RHT-0040
<b>AFS-3</b>	RAD-0150A – RAD-0200A RHT-0060 – RHT-0080
<b>AFS-4</b>	RAD-0250A – RAD-0300A RHT-0100 – RHT-0120

### 11.2.2 Magnetic Condenser Filters

Model	Use With Air Dryer
<b>AFR-1</b>	RAD-0025A – RAD-0055A RHT-0010 – RHT-0020
<b>AFR-2</b>	RAD-0075A – RAD-0100A RHT-0030 – RHT-0040
<b>AFR-3</b>	RAD-0150A – RAD-0200A RHT-0060 – RHT-0080
<b>AFR-4</b>	RAD-0250A – RAD-0300A RHT-0100 – RHT-0120

### 11.2.3 Programmable Timer

Model	Use With Air Dryer
<b>APT-1</b>	RAD-0075A* – RAD0200A* RHT-0030* – RHT-0080*
<b>APT-3</b>	RAD-0250A* – RAD-0300A* RHT-0100* – RHT-0120*

*\*Aftermarket timer can ONLY be installed on units built after a certain date. Please contact Altec AIR (Section [11.3](#)) to confirm this option is available for your unit. Reference AAPN-000086.*

**11.2.4 Zero Loss Drain**

<b>Model</b>	<b>Use With Air Dryer</b>
<b>AZD-13*</b>	RAD-0250/0300-3
<b>AZD-14*</b>	RAD-0250/0300-4/5
<b>AZD-23</b>	RAD-0400/0500/0600-3
<b>AZD-24</b>	RAD-0400/0500/0600-4/5
<b>AZD-34</b>	RAD-0750/1000/1250-4/5
<b>AZD-44</b>	RAD-1500/2000-4/5

*\*Aftermarket drain can ONLY be installed on RAD-0250/0300 units built after a certain date. Please contact Altec AIR (Section [11.3](#)) to confirm this option is available for your RAD-0250/0300 unit. Reference AAPN-102.*

**11.3 Ordering Parts from Altec AIR**

Once you have identified your required parts and accessories, contact the Altec AIR Inside Sales / Service department to order:

(800) 521-5351 (**option 2**)

Fax – (303) 657-2205

[sales@AltecAIR.com](mailto:sales@AltecAIR.com)

[parts@AltecAIR.com](mailto:parts@AltecAIR.com)

## 12. Contacting Altec AIR

### 12.1 General

Altec AIR, LLC  
226A Commerce Street  
Broomfield, Colorado 80020

(800) 521-5351

(303) 427-3700

Fax – (303) 657-2233

[info@AltecAIR.com](mailto:info@AltecAIR.com)

[www.AltecAIR.com](http://www.AltecAIR.com)

### 12.2 Sales

(800) 521-5351 (**option 2**)

Fax – (303) 657-2205

[sales@AltecAIR.com](mailto:sales@AltecAIR.com)

[parts@AltecAIR.com](mailto:parts@AltecAIR.com)

### 12.3 Service

(800) 521-5351 (**option 3**)

Fax – (303) 657-2205

### 12.4 Technical Support

(800) 521-5351 (**option 1**)

### 13. Appendix

#### 13.1 Wiring Diagram

##### 13.1.1 RAD-0025 through RAD-0055 and RHT-0010 through RHT-0020

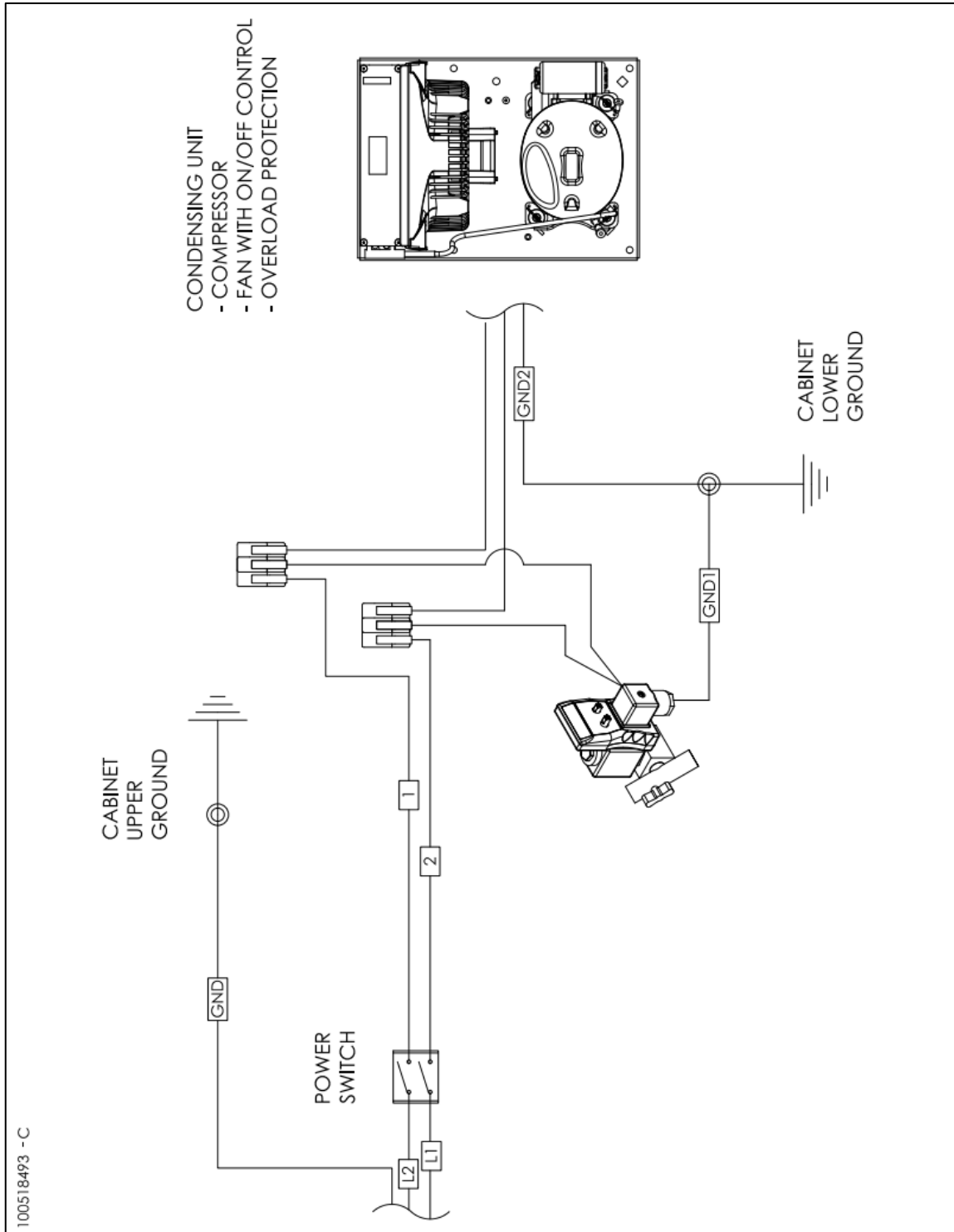



13.1.2 RAD-0075 through RAD-0200 and RHT-0030 through RHT-0080

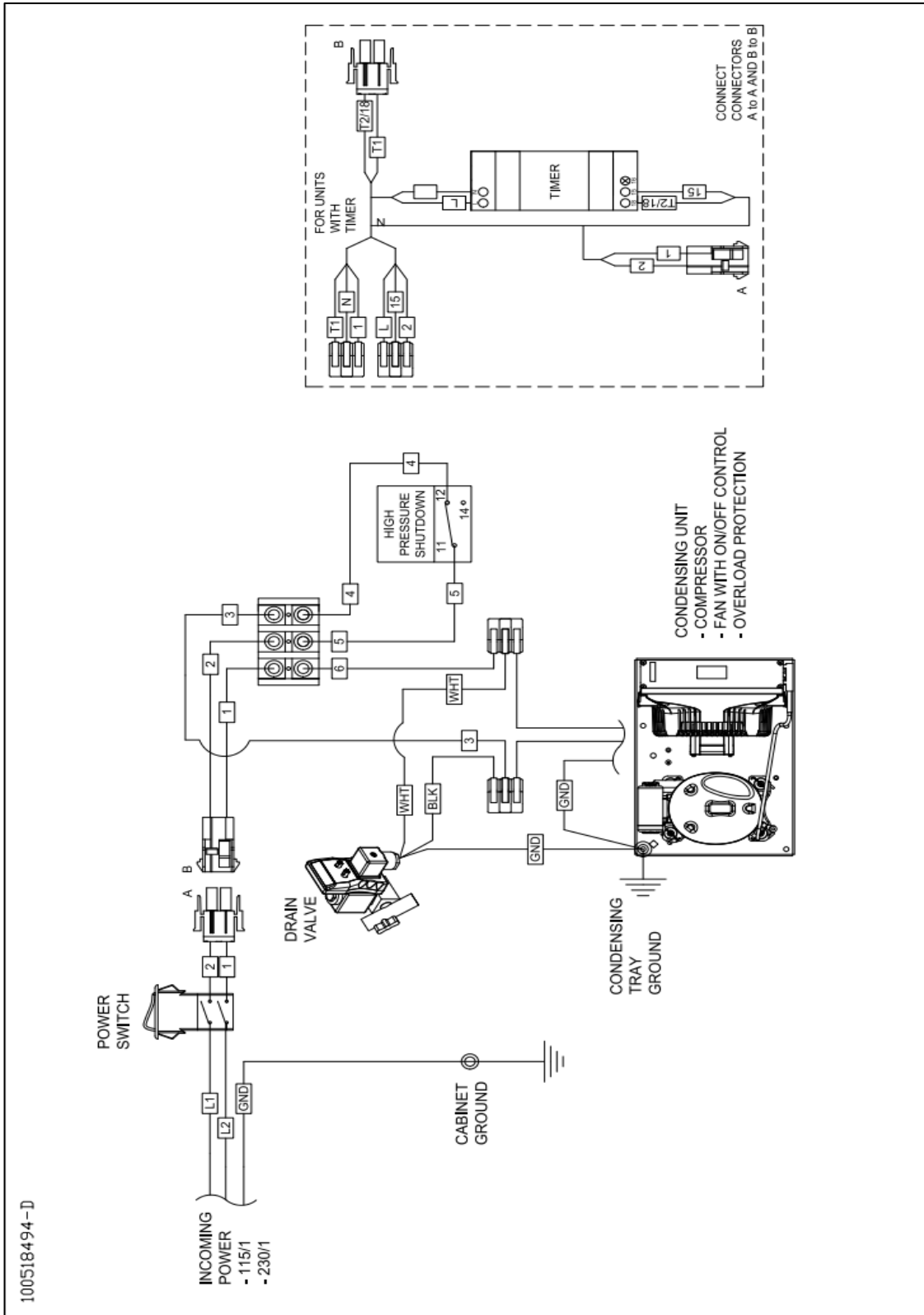

13.1.3 RAD-0250 through RAD-0300 and RHT-0100 through RHT-0120 (230V)

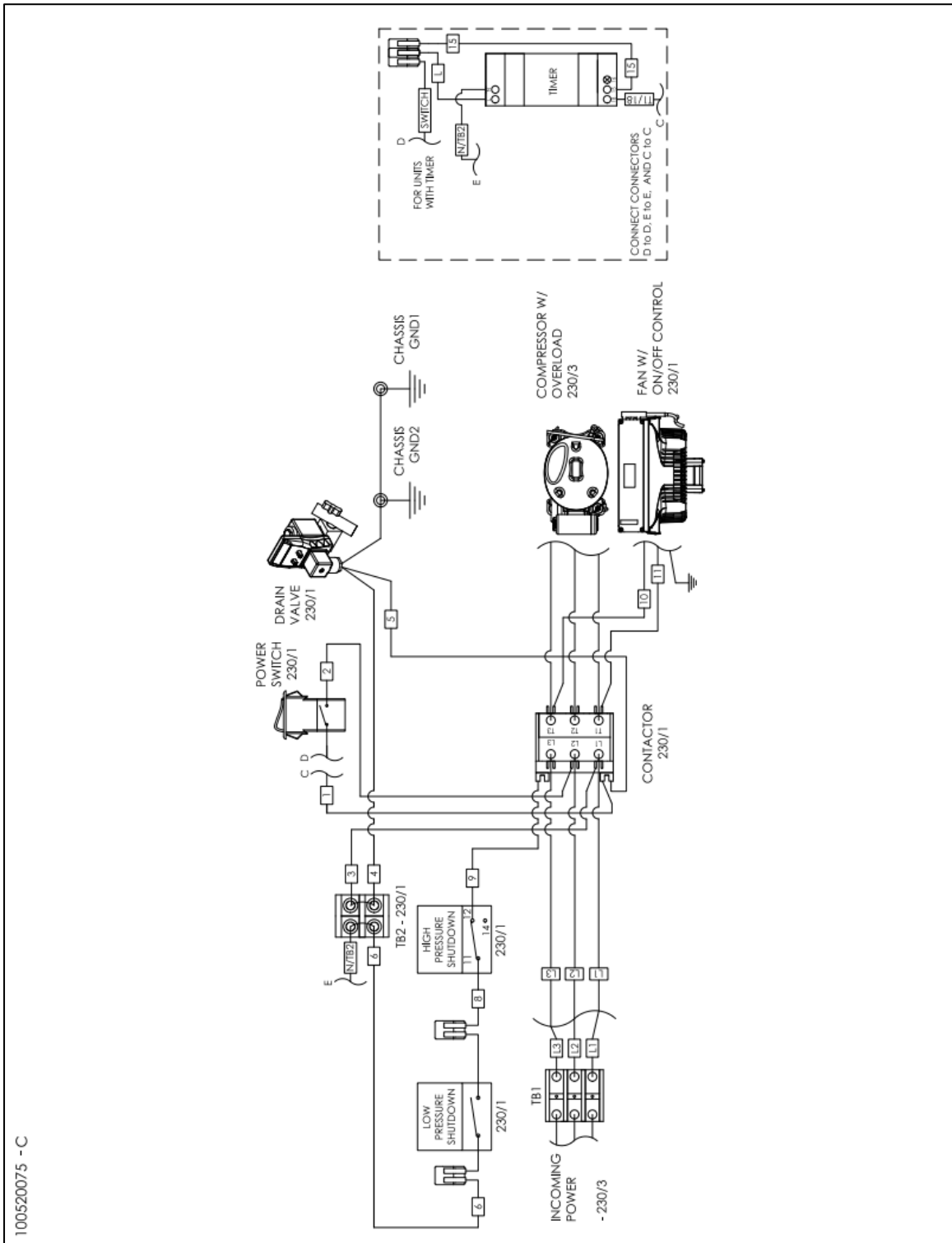

**13.1.4 RAD-0250 through RAD-0300 and RHT-0100 through RHT-0120 (460/575V)**

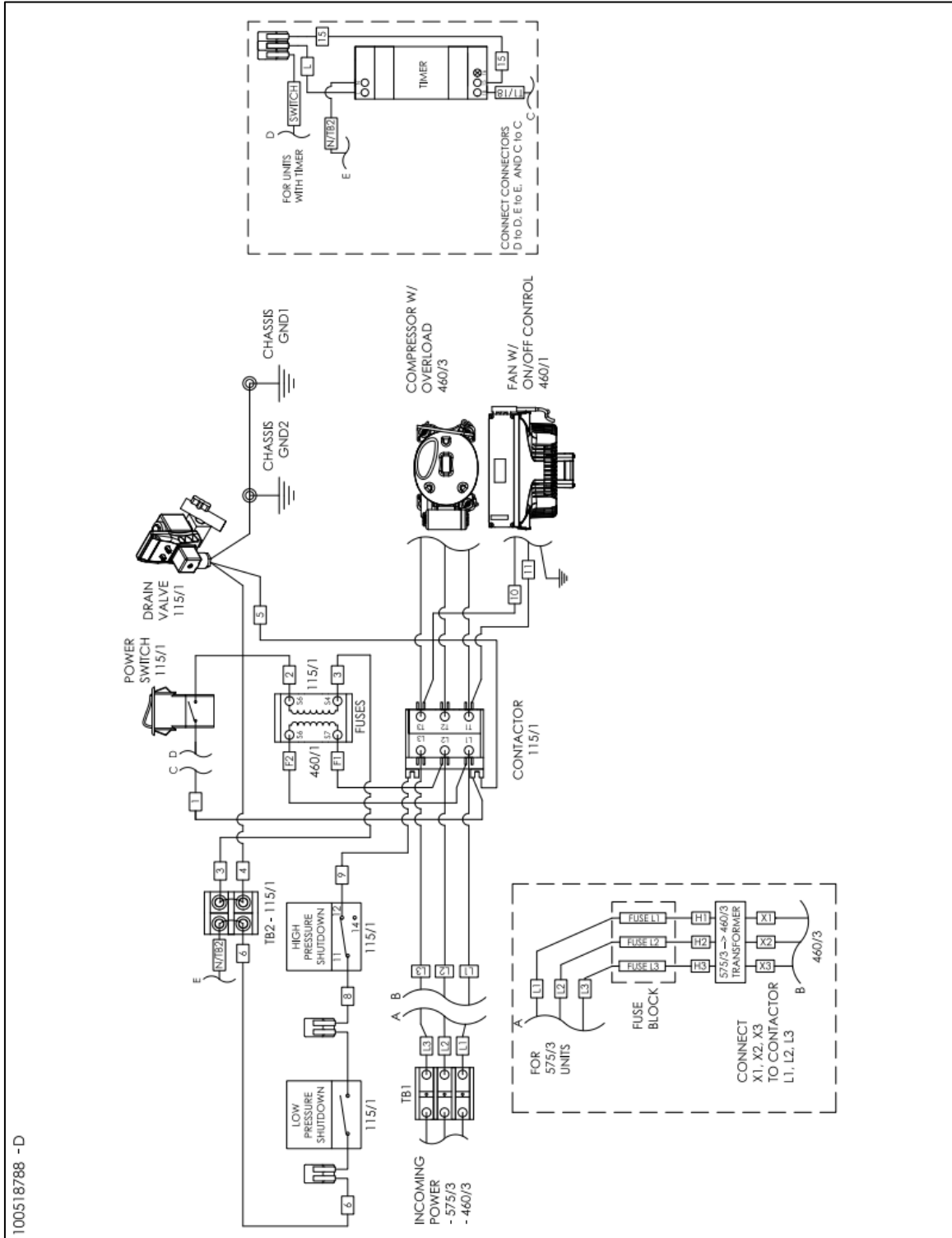

13.1.5 RAD-0400 through RAD-0600 (230V)

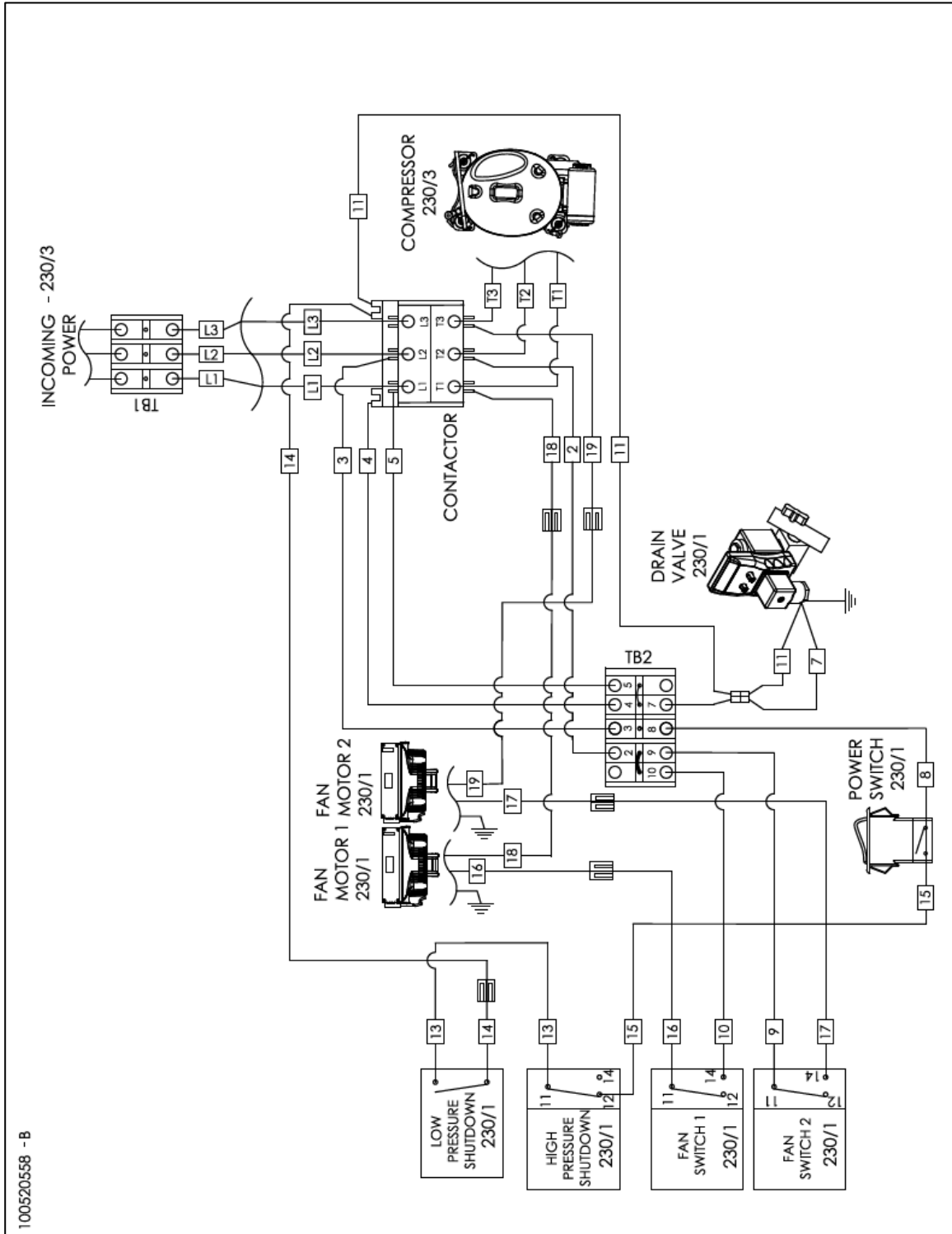

13.1.6 RAD-0400 through RAD-1250 (460/575V)

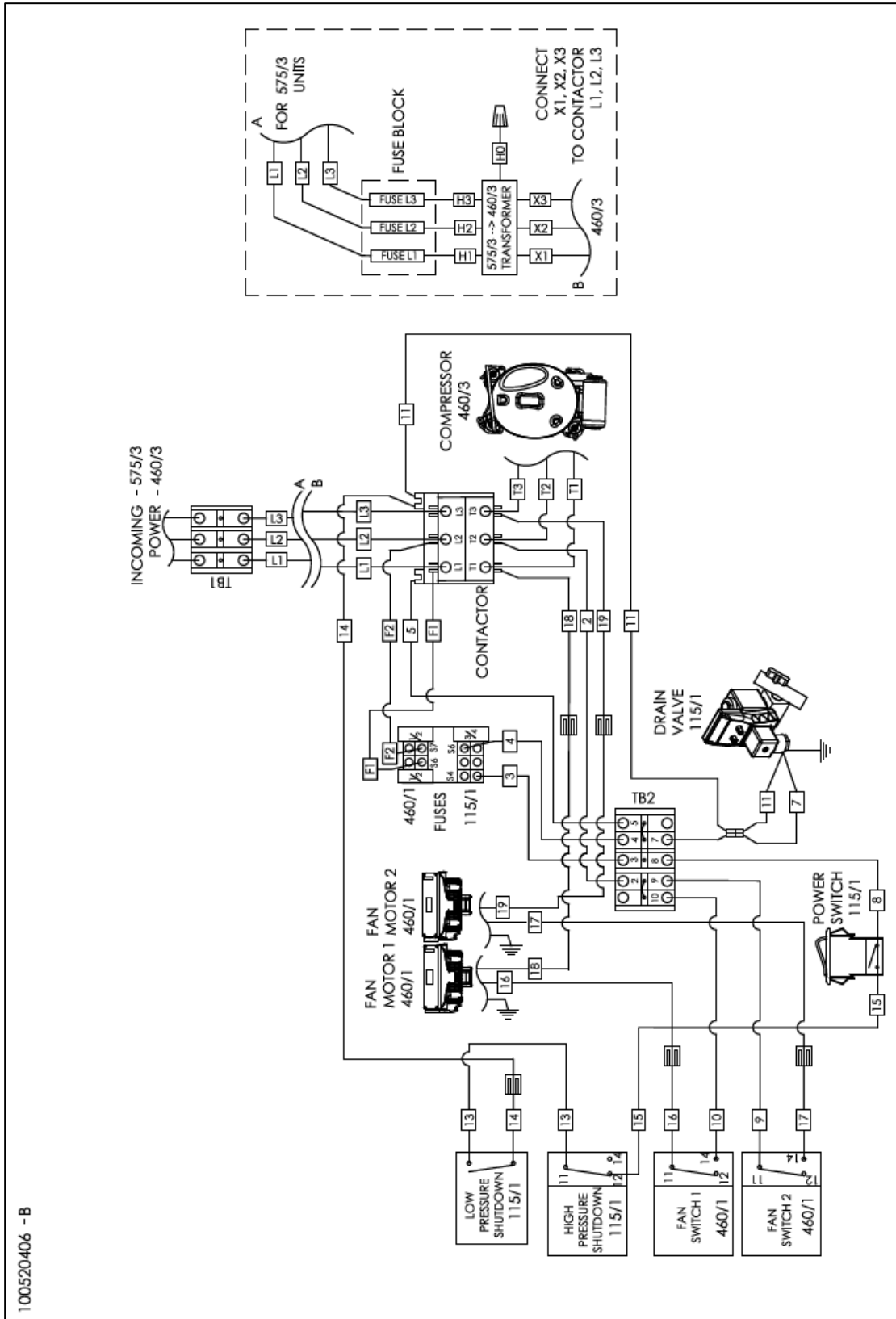

**13.1.7** RAD-0400-D through RAD-600-D (230V) and RAD-0400-D through RAD-2000-D (460/575V)

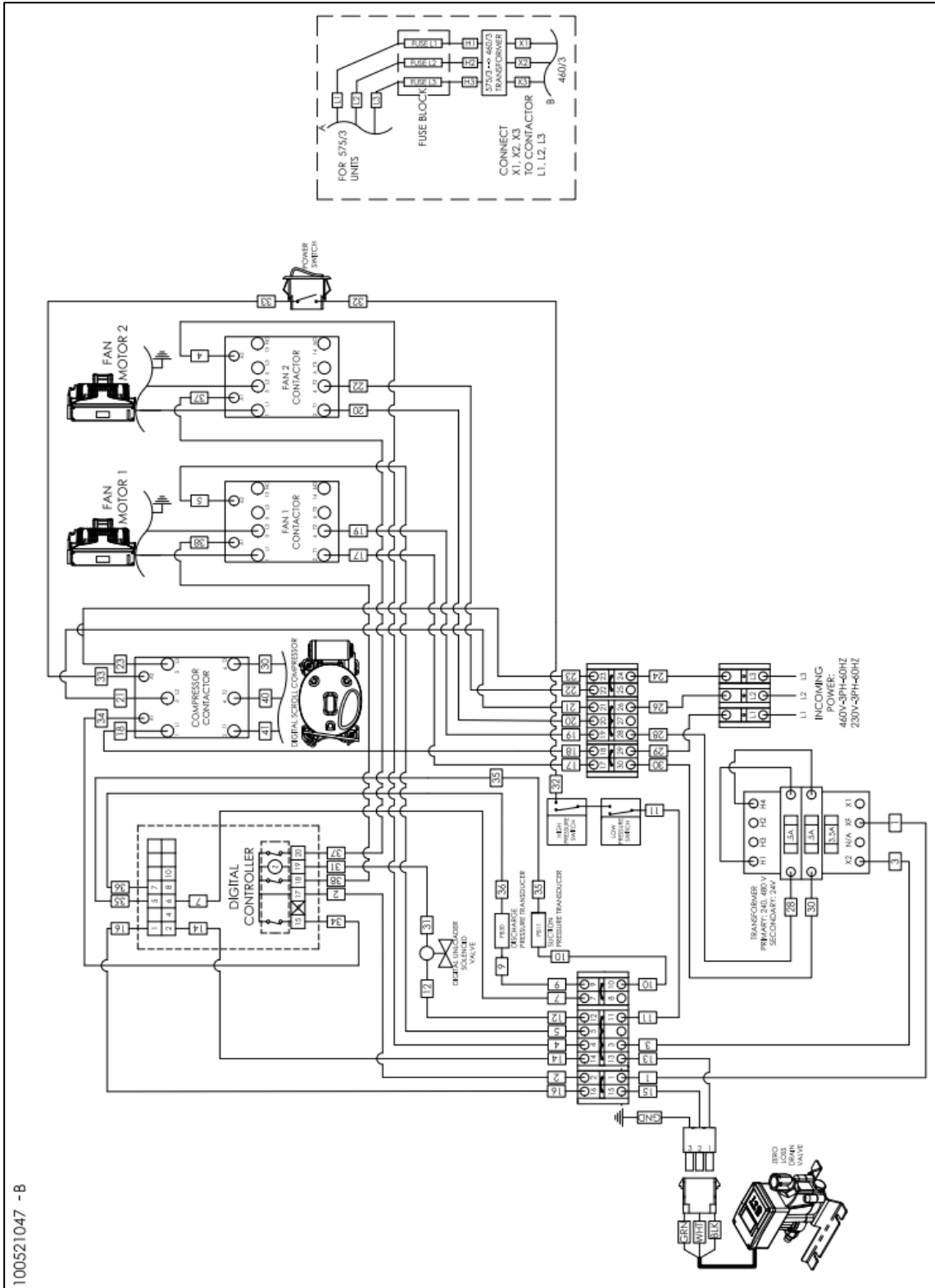

13.1.8 RAD-1500 through RAD-2000 (460/575V)

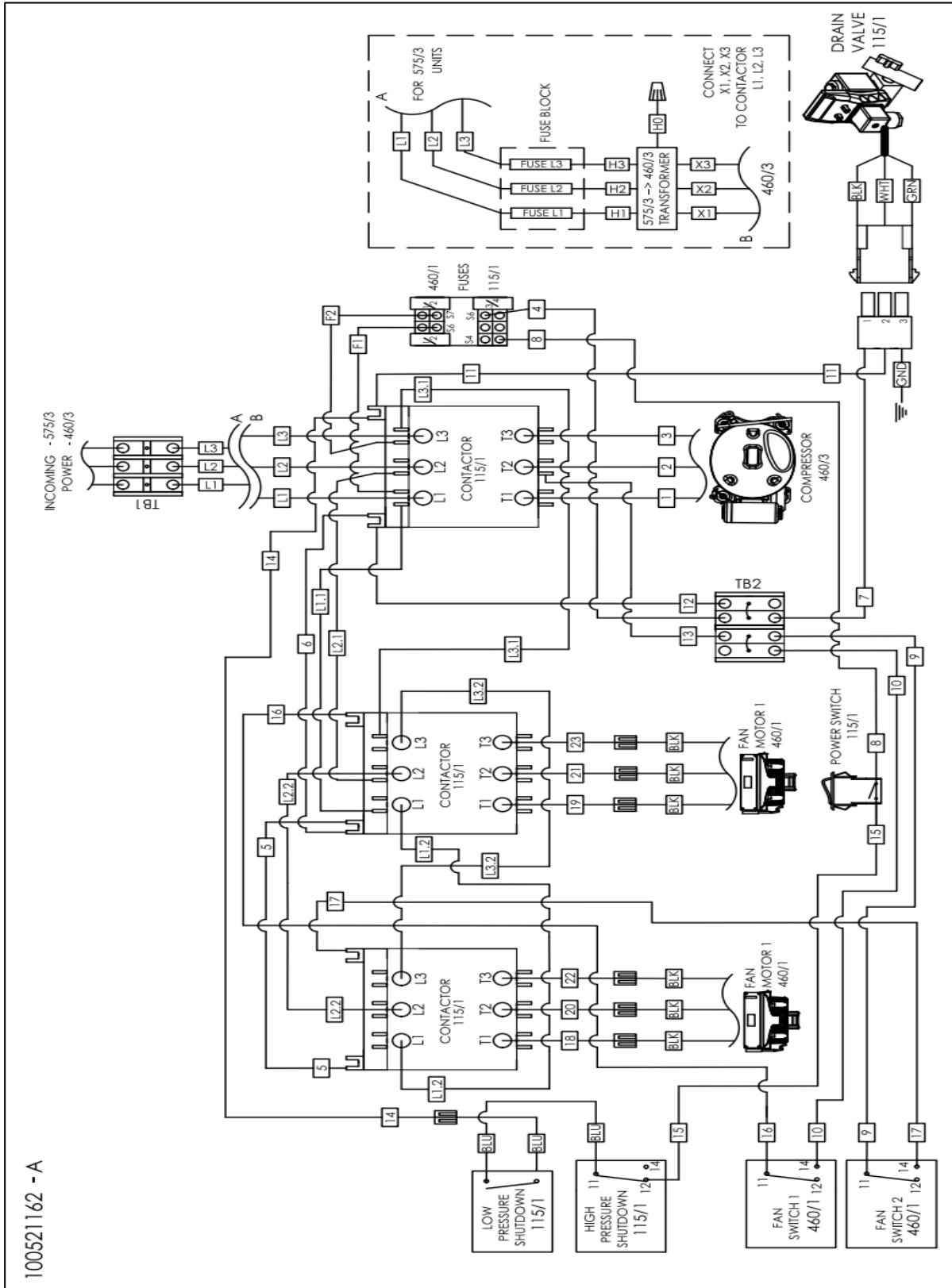

## 13.2 P Series Timer – Add on Option

### 13.2.1 Programming Your Timer

#### 13.2.1.1 Front View

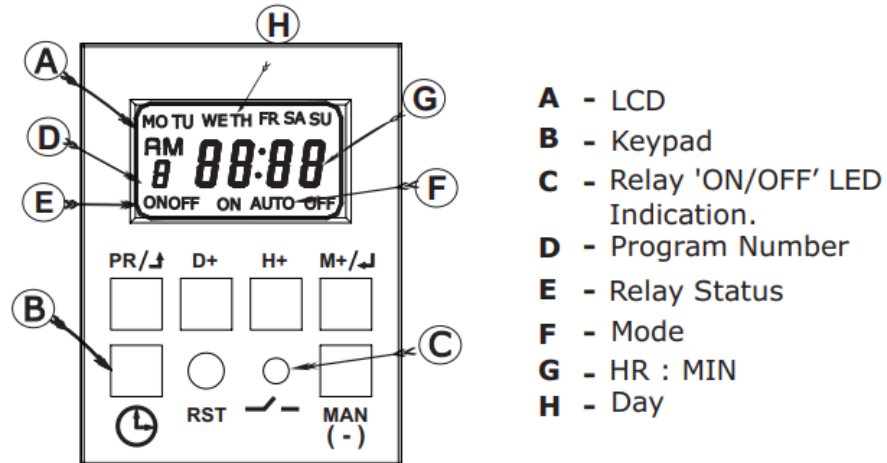

#### 13.2.1.2 Key Functions

- PR / - Program key to view & edit programs & As ESC key
- D+ - Day selection & Also as an Date/DST increment key
- H+ - Hour increment & Also as a Date/DST decrement key
- M+ / - To increment minute & Also as an enter key
- (H+) + (M+) - To enter in Date/DST mode
- RST - Reset programs & settings in the device
- MAN (-) - Manual key for overriding & also to decrement D/H/M in program mode
- Clock key to set the clock
- CLK + MAN - To set 12 / 24h clock mode
- CLK + PR - To lock / unlock keypad

#### 13.2.1.3 Clock Settings

- + MAN - Press clock key & MAN key simultaneously to toggle between 12 / 24-hour clock mode.  
**AM / PM**
- + D+ - Keep the Clock key pressed & then press the D+ key to set day.  
**MO/TU/WE/TH/FR/SA/SU**
- + H+ - Keep the Clock key pressed, then press the H+ key to set hour.  
**00 - 23 IN 24 HR MODE**  
**01 - 12 IN 12 HR MODE**
- + M+ - Keep the clock key pressed, then press M+ key to set min.  
**00 - 59**



## 13.2.1.4 DST &amp; Date Settings

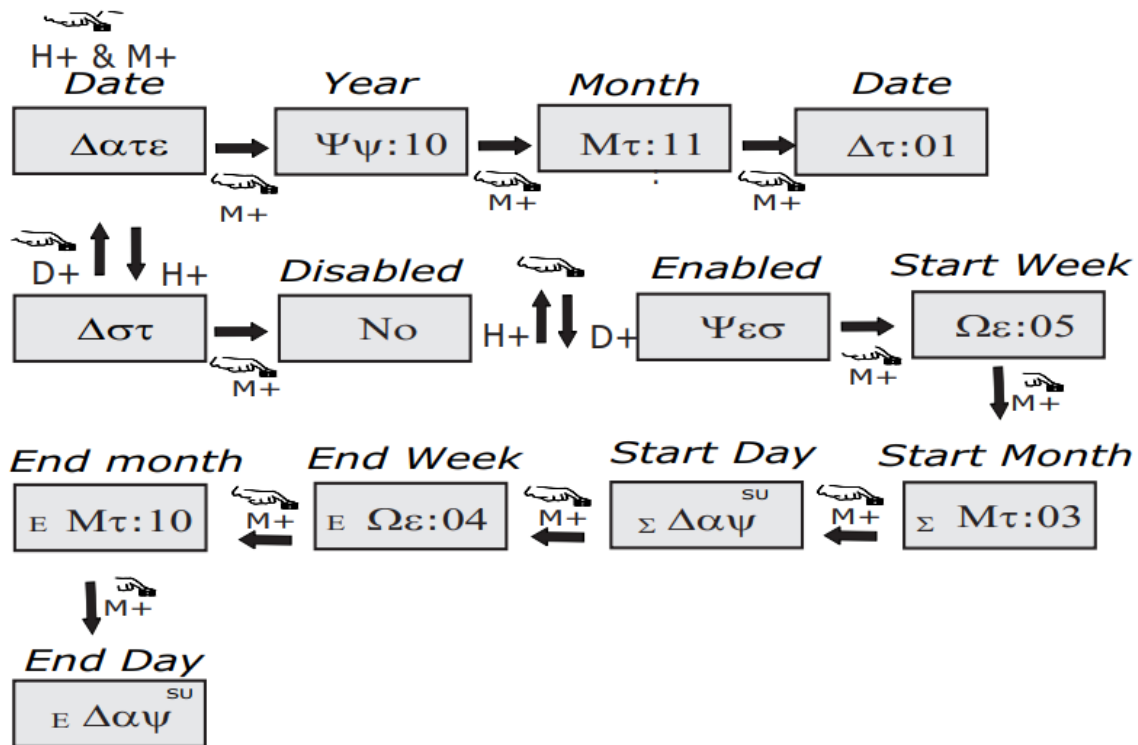

- During Run mode, press H+ with M+ to enter 'dAtE' menu. Press M+ to enter this menu. Edit YY, []t & dt using D+ or H+.
- 'dAtE' menu is being displayed, press H+ or D+ to select DST & press M+ to enter its menu.
- User can enter DST & Date as shown in the figure 2 above.
  - For this, D+ key is used to increment the parameter value
  - H+ key is used to decrement the parameter value
  - M+ key is used to save the current parameter value
  - PR key is used to escape to previous parameter screen
- During DST period 'd' will appear at bottom left corner of the screen & day will be updated according to current date. No need to set day manually by pressing CLK & D+ key

**Note:**

1. DATE & DST must be set in regions where DST is observed. When DST is enabled, LCD shows 'd' at the left corner.
2. DST Start / End: Clock is rolled over from '02:00' to '03:00' at start and is rolled over from '03:00' to '02:00' at end.
3. When DST period starts, clock gets incremented by 1 hour. If the user has set the clock prior to setting the DST and accounted for this additional hour that would get incremented, then the user might have to readjust the clock.

**13.2.1.5 Manual Override & Mode Description**

Press MAN key to toggle between-

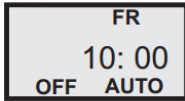

1. **AUTO:** As per set program.



2. **ON AUTO:** Manual ON up to next ON event.

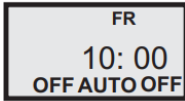

3. **AUTO OFF:** Manual OFF up to next OFF event.

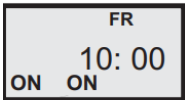

4. **ON:** Manual ON (Continuous).

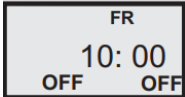

5. **OFF:** Manual OFF (Continuous).

**13.2.1.6 Programming Details**

25 ON/OFF Programs																								
1	2	3	4	5	6	7	8	9	A	B	C	D	e	f	G	H	J	L	n	P	q	T	u	Y

**Screen 1:**

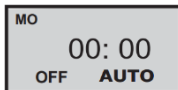

After power ON screen 1 will be displayed.

**Screen 2:**



Set the current time (e.g., 10:00), Day (e.g., Friday) & Relay mode (e.g., AUTO) as per CLOCK setting and mode function.

PR /

- Press PR to enter in ON/OFF time program.

**Screen 3:**

Press D+ stepwise for day selection as given below. Mon to Sun is default setting.

1. **MO TU WE TH FR SA SU** (All Weekdays)
2. **MO TU WE TH FR SA** (Exclude Sunday)
3. **MO TU WE TH FR** (Exclude Weekends)
4. **MO TU WE TH SU** (Exclude Friday & Saturday)
5. **SA SU** (Only weekends)
6. **FR SA** (Only Weekends)
7. **TU WE TH FR SA SU** (Exclude any Single Day)
8. **MO/TU/WE/TH/FR/SA/SU** (Include any Single Day)
9. **MO WE FR SU** (Exclude Alternate Days)
10. **TU TH SA** (Exclude Alternate Days)

**Screen 4:**

Press H+ to edit & increment the hour as & if needed, use MAN (-) key to decrement hours.

**Screen 5:**

Press H+ to edit & increment the hour as & if needed, use MAN (-) key to decrement hours.



To save & exit the program, press the  key.

Program up to 25 individual programs as desired or needed.

**How to Delete the Program?**

1. To delete single program, go to respective program, press H+ until '--' hr comes & press M+ until '--' min comes on LCD. '--:--' displayed on LCD indicates empty program.
2. To delete/reset all the programs & settings, press RST key.

**KEYPAD LOCK:**



To lock the keypad, press the  and the 'PR' key simultaneously for 3 seconds or more. 'bLoC' will appear on the screen indicating that the keypad has been locked. When the keypad is locked none of the parameters can be edited, only the mode can be changed from 'Auto' to 'ON Auto' and 'Auto OFF' by pressing the 'MAN' key. To unlock  the keypad press ' ' and PR key simultaneously for 3 or more sec. 'ULoC' will appear on screen. The keypad can be locked only in Run mode and not in program Edit mode.

**13.2.2 Troubleshooting Your Timer**

### 13.2.2.1 Troubleshooting Matrix

Possible Cause	Check	Correction
Timer Wired Incorrectly	Verify timer is wired per the wiring diagram	Rewire according to wiring diagram
Timer programming has not been set	Verify programming has been set on timer	Program the timer per "Programming your Timer" section above
Backup Battery lost charge	Verify timer buttons and screen operate when there is no power to unit	Replace backup battery
Timer has Malfunctioned	All of the above	Contact Altec AIR technical support (800) 521-5351

### 13.2.2.2 Frequently Asked Questions

1. **QUESTION:** In event of power failure, do I lose all my programs?
1. **ANSWER:** No, because battery has a reserve of approx. 6 yr. at operating temperature. In absence of power, we can program the device as per requirement. However, during power fail, relay or LED will not operate but the relay status can be observed on LCD screen.
2. **QUESTION:** How to use Manual override? When is it applicable?
2. **ANSWER:** Press MAN key to toggle to ON Auto, Auto OFF, ON or OFF mode. (Refer Mode Description). It is used if user requires an immediate ON or OFF of the relay.
3. **QUESTION:** Can I select any day in the week as my weekly OFF?
3. **ANSWER:** Yes, when in PR mode, toggle by pressing D+ & MAN (-) or D+ key respectively to select individual holiday selection.
4. **QUESTION:** What should I do to remove all programs & reset RTC?
4. **ANSWER:** Press RST key. All programs will get deleted, RTC will be reset to 00:00 & Default day as Monday.
5. **QUESTION:** How do I change clock format from 12 h to 24 h?
5. **ANSWER:** Press  & MAN  simultaneously to switch clock format from 12h to 24 h & vice-versa.
6. **QUESTION:** How does ON AUTO & AUTO OFF feature help?
6. **ANSWER:** ON AUTO / AUTO OFF feature bypass the current program & continues with the next program. ON AUTO mode returns back to AUTO mode at next programmed ON Time. AUTO OFF mode returns back to AUTO mode at next programmed OFF Time. In this way, one can override the relay to switch ON/OFF without affecting the further programs.

## 13.3 Zero Loss Drain – Add on Option

### 13.3.1 Operating Your Drain

**13.3.1.1** Pressurize the condensate drain as follows:

- Ensure the drain has been installed properly.
- Make sure the plant system is pressurized.
- Open the pressure supply valve slowly and check for any leaks within the system. See the depressurization section if any leaks are present.
- The drain is now ready for use.

**13.3.1.2** Depressurize the condensate drain as follows:

- Close the pressure supply valve.
- Depressurize the drain by repeatedly pressing the TEST button until no further discharge noise is heard.
- Turn off the power supply and disconnect the power to the unit.
- The drain may now be disassembled to repair the leak.

**13.3.2** Control Panel & Alarms

**13.3.2.1** The drain may be monitored using the control panel on the top face of the device. This includes 2 status display LEDs, and a malfunction button.

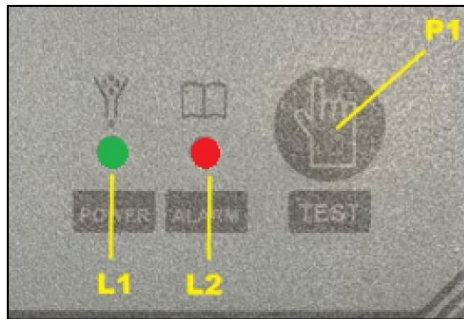

- L1, Green LED: “POWER” status indicator
- L2, Red LED: “ALARM” status indicator for faults
- P1, multifunction “TEST” button

Refer to the control panel matrix below for indicator explanations.

Operating Status	Description	L1	L2	P1	Value	Alarm
Supply Voltage Missing	The condensate drain is disconnected from the power supply. The operating functions are deactivated. An alarm signal is remotely transmitted outside.					Constant ON
Stand by, there is no condensate	The supply voltage is applied and the condensate drain is ready to operate. If no condensate is discharged for 3 hours, the software performs a brief forced discharge. The LED is constant green on and the condensate drain activates the same routine until there is a normal discharge that brings the sensor back to the minimum level.	Constant ON			OFF (3 hours) ON (2 sec.)	
Automatic Condensate Discharge	The maximum level is reached. The valve opens (with a delay of 10 seconds) and the condensate is discharged. The valve closes, as soon as the minimum level is reached.	Flashing slowly			ON (max 20 sec.)	
Cleaning routine 1	Even if the valve is opened, the minimum level is not reached within 20 seconds. The condensate drain tries with repeated ON/OFF cycles to unblock the situation probably due to clogging.		Flashing slowly		30 x ON (2 sec) OFF (2 sec)	
Cleaning routine 2	Notwithstanding the valve being subject to 2 minutes of ON/OFF, the minimum level has not been reached. The condensate drain continues to operate as a timer, continuing with the ON/OFF sequence and continues with alarm modalities.		Flashing quickly		ON (3 sec) OFF (60 sec)	Constant ON
Irreversible Error	A fault has occurred in the system. Try with the reset function. If the problem reoccurs, it requires a technical intervention.		Constant ON		ON (3 sec) OFF (60 sec)	Constant ON
Manual Condensate Draining	When the Test button is pressed the condensate is discharged manually.	Flashing quickly		ON (max 3 sec.)	ON (3 sec max)	
Reset	When a reset of the micro's control logic in an alarm state is required. If the problem persists, the alarm, the alarm state will be activated after a short period.	Green LED and red sequence and then constant green is ON		ON (> 5 sec.)		

### 13.3.3 Troubleshooting Your Drain

**13.3.3.1** Refer to the troubleshooting matrix or contact the Altec AIR technical support team at (800) 521-5351.

Error	Reason	Solution
The drain does not discharge condensate: the condensate drain does not indicate an alarm. (status 3 standby).	There is no condensate in the condensate drain: • The external shut-off valve between the discharge point and the condensate drain is closed. • The externally installed filter is clogged. • The condensate drain has not been installed correctly. There may be a siphon effect and/or air bubble upstream of the condensate drain. • The supply voltage is not powering the condensate drain.	Check the supply shut-off valve of the condensate drain. • Control the filter that might be installed externally in the condensate supply line. • Check the installation. See Chapter 3, Paragraph 2. • Ensure that the tube leading to the condensate drain is free. • Ensure that there is electrical power. • If the aforementioned points have been verified, the condensate drain is operating correctly. • Try a manual discharge with the TEST button.
The condensate drain discharges continuously.	Malfunction of the discharge valve diaphragm: • The diaphragm is blocked by dirt. • The diaphragm is defective or worn out.	• Clean the diaphragm. • Replace the diaphragm, if necessary, with the "Maintenance Kit". See Chapter 8 "Maintenance"
The condensate drain is not discharging and the status 5 of the cleaning routine 1 is active. (L2 slowly flashing).	The level sensor takes more than 20 sec to discharge the condensate and reach the minimum level: • The double mesh integrated filter is clogged, dirty or defective. • The line at the condensate outlet is clogged. • The amount of condensate is too high.	Clean the integrated filter or substitute it if necessary. See Chapter 8 "Maintenance". • Check that there are no obstructions in the line at the condensate outlet. • Try a manual discharge with the TEST button. • Ensure that the condensate drain is correctly sized for the application.
The condensate drain does not discharge and the status 6 of the cleaning routine 2 (L2 quick flashing) is lit up. The c.d. is in an alarm situation.	The sensor has not managed to discharge for more than 2 minutes and reach the minimum level: • The double mesh integrated filter is clogged, dirty, or defective. • There is a great deal of dirt inside the condensate drain and on the plastic sensor rod/float. The float is blocked and/or descends with difficulty. • The diaphragm is clogged or blocked. • The tube at the condensate outlet is blocked. • There is an excessive quantity of condensate	Clean integrated filter or replace it if necessary. See Chapter 8 "Maintenance". • Clean the condensate drain internally, remove any possible dirt from the level sensor rod and float. WARNING: do not force, fold, or lever the level sensor rod. Any possible damage might compromise the condensate drain's operations. • Clean the diaphragm and if necessary, replace it. • Check that there are no obstructions in the line at the condensate outlet. • Try a manual discharge with a TEST button. • Make sure that the condensate drain is correctly sized for the application.
The condensate drain is in an alarm situation, status 7. (L2 is constantly lit).	There is an irreversible error in the condensate drain.	Try resetting the micro logic. • If the problem persists, substitute the condensate drain.
The manual discharge does not work correctly, status 8 (P1).	Possible clogging or malfunction of the condensate drain solenoid valve. • The coil makes a "click" sound, but the discharge does not take place. The diaphragm is probably blocked, or the filter is clogged and dirty. • The condensate drain only discharges air. The diaphragm is dirt or worn out. • The coil does not make any sound and the condensate drain does not discharge. The solenoid valve is defective.	• Clean the diaphragm and if necessary, replace it. See Chapter 8 "Maintenance". • Clean the integrated filter or replace it if necessary. See Chapter 8 "Maintenance". • Substitute the condensate drain if necessary.

### 13.3.4 Maintaining Your Drain

**13.3.4.1** The following section provides a recommended preventative maintenance schedule, kit, and instructions to ensure that your drain continues to operate at its peak performance.

Please refer to the Operating your drain section for unit depressurization prior to any maintenance work being performed.

#### 13.3.4.2 Recommended maintenance intervals:

13.3.4.2.1 The following table provides a recommendation for maintenance activities to prevent malfunctions and/or critical failures due to the wear and tear of components.

#### Maintenance Kit :

Maintenance Kit		
Item Number	Description	Quantity
100520825	KIT; MAINTENANCE; RAD SERIES; ZERO LOSS DRAIN; FILTER REPLACEMENT	1

#### 13.3.4.3 Visual Inspection and Verification of the correct operation:

- Inspect the drain for any external damages or leaks.
- Check the operating state of the drain by reviewing the LED indicators on the control panel (See section “Control Panel & Alarms”)
- Push the “TEST” button to verify the operating status of the drain as well as proper condensate discharge of the unit. (See section )

#### 13.3.4.4 Cleaning and/or replacing the integrated filter:

- Unscrew and remove the filter cap.
- Clean the filter, if necessary, replace it.
- Replace the filter onto the seat of the filter cap.
- Screw in the cap/filter assembly back into the drain paying close attention not to damage the plastic threading of the valve body.



**13.3.4.5 Repair/Replacement of wear and tear items and cleaning of drain:**

- Open the condensate drain, unscrewing the 4 M6x25 screws (pos. 12) as well as the M3x10 screws (pos. 13) and remove the valve assembly (pos. 11).
- Unscrew the filter cap (pos. 04) and extract the integrated filter. See Paragraph 7.2 concerning this.
- Remove the O-Ring gasket of the valve assembly (pos. 07), the O-Ring gasket of the filter cap, the solenoid valve spring (pos. 08), the solenoid valve pilot (pos. 09) and the diaphragm with the diaphragm guide (pos. 10).
- Clean the internal housing of the valve assembly and the aluminum tank.
- If necessary, clean the level sensor rod and its float, paying however particular attention to not damage it. Do not bend it and do not use it as a lever. It contains electronic material. Mechanical stresses, including moderate ones, can give rise to irreparable malfunctions.
- Insert the new O-Ring of the filter cap, place the new filter on the cap and close on the valve assembly paying attention to correctly screw it.
- Insert the new valve assembly O-Ring.
- Insert the valve components in the following order: spring and pilot in its spool, first insert the spring (insert the side without plastic of the pilot inside the spring) and lastly the diaphragm with its plastic guide. Ensure that diaphragm is correctly positioned.
- Therefore, screw the valve assembly onto the condensate drain, tightening the 8 screws present with the following tightening torque values: M6 = 8 Nm +2/-1 Nm, M3 = 0,4 Nm ±15%.
- Replace the plastic ring (pos. 15) with the straight flow regulator (pos. 14).
- The container chamber of the electronic board is sealed with a sealing gasket and must not be opened. All of the required connections can be accessed from the outside by electrical connectors.

13.3.4.6 CSED models exploded view diagram:

**CSED models exploded view diagram**

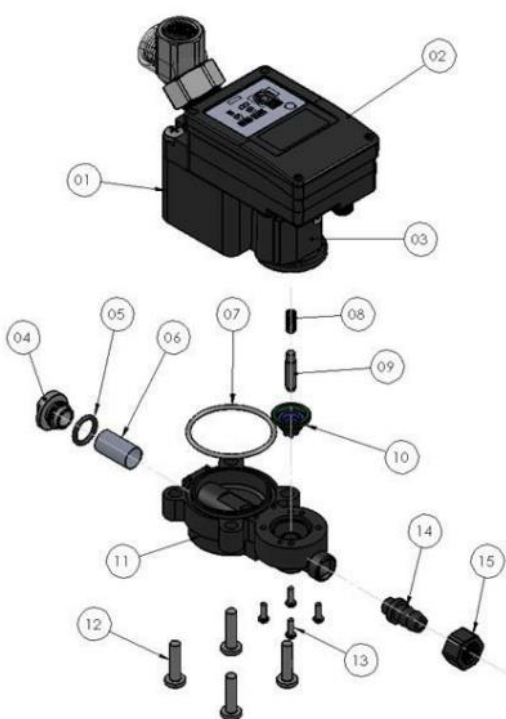

Pos	Description	Quantity
Components not concerned by changes of parts.		
01	Tank and level sensor	-
02	Electronic board	-
03	Solenoid valve	-
Components present in the maintenance kits		
04	Filter cap	1
05	O-Ring	1
06	Double mesh metallic filter	1
07	Valve assembly O-Ring	1
08	Solenoid valve spring	1
09	Solenoid valve pilot	1
10	Diaphragm with the diaphragm guide	1
11	Valve assembly	1
12	M6x25 cross recessed screws	4
13	M3x10 cross recessed screws	4
14	Flow limiter	1
15	Flow limiter plastic ring	1

### 13.4 Digital Scroll Option

**13.4.1** The Closed Loop Digital Controller monitors the refrigeration system high side and low side pressures, cycles the condenser fan motors on and off, loads and unloads the digital scroll compressor based on the current heat load (Air flow) going through the dryer.

NOTE: The CLD controller is pre-set at the factory. No adjustments are necessary or should be made.

Upper Display	Lower Display	Icons
Suction temperature or pressure	Discharge temperature or pressure	- Active loads - Measurement units



LED	Function	Meaning
°C	On	Degrees Celsius
°F	On	Degrees Fahrenheit
bar	On	Bar displaying
PSI	On	PSI displaying
kPa	On	kPa displaying
1	On	Digital compressor on
1	Flash 1/sec	Digital compressor waiting to start
1	Flash 2/sec	Digital input alarm for digital compressor OR Digital compressor in maintenance status
2	On	Compressor 2 on
2	Flash 1/sec	Compressor 2 waiting to start
3	On	Fan 1 on
3	Flash 1/sec	Fan 1 waiting to start
4	On	Fan 2 on
4	Flash 1/sec	Fan 2 waiting to start
⚡	On	Digital solenoid valve coil is energized

## 14. Warranty Statement

For updated and current Warranty information, please visit:

[www.altecair.com/about-altecair/warranty.html](http://www.altecair.com/about-altecair/warranty.html)

---

### Registration Reminder

If you haven't already done so, please take a moment to register your Altec AIR Refrigerated Non-Cycling Series Air Dryer. **Registering is necessary to activate this Limited Warranty on your product.** Once you register, you are eligible to receive free technical support, as well as updates concerning your Altec AIR products.

*See Section 7. for details on Registering Your Air Dryer.*

