

P210WLP Series Air Dryer

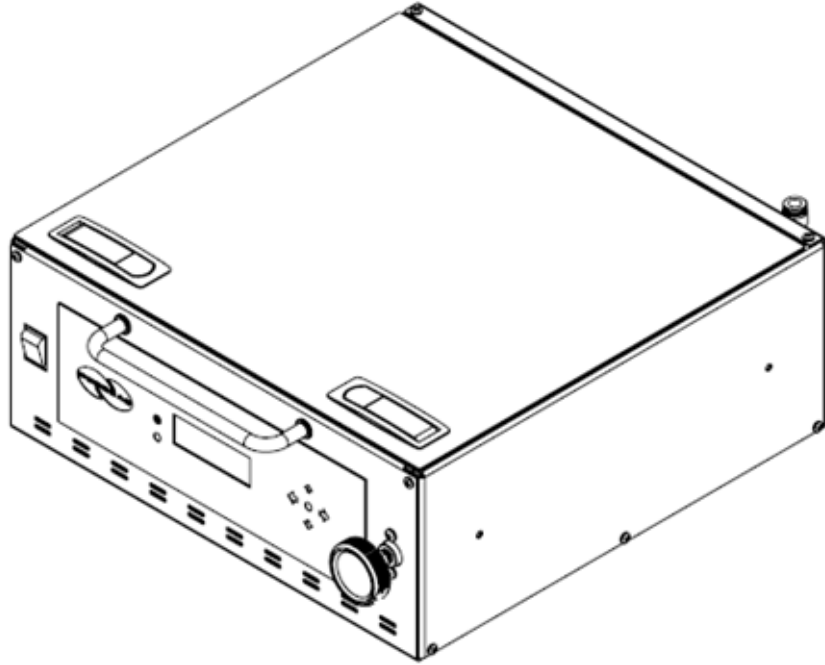

User's Guide

Models covered:

P210WLP P210WLP-V P212WLP





WARNING:

This product can expose you to chemicals including Lead, which is known to the State of California to cause cancer/birth defects or other reproductive harm. For more information go to www.P65Warnings.ca.gov

1. Welcome & Congratulations

Congratulations on your purchase of a new PUREGAS P210WLP Series Air Dryer! We here at Altec AIR are very proud of our products, and we are committed to providing you with the best value and service possible.

We are sure that you will be satisfied with your new Air Dryer and would like to thank you for choosing Altec AIR for your Air Dryer requirements. We also hope that you will continue to choose us for your future air pressure and related product purchases.

For information about this and other Altec AIR products, please visit us on the web at:

www.AltecAIR.com

2. Introduction

PLEASE READ THIS USER'S GUIDE THOROUGHLY AND SAVE FOR FUTURE REFERENCE.

This User's Guide is provided for the benefit of our customers and contains information and direction specific to the PUREGAS P210WLP Series Air Dryers. Models covered include P210WLP, P210WLP-V, and P212WLP. This guide covers topics including safety, specifications, installation, registration, operation, testing, maintenance, replacement parts, service, and troubleshooting issues. Observation and compliance with this User's Guide will ensure the maximum life and efficiency of your Air Dryer.

This User's Guide should be read thoroughly prior to installing, operating, or servicing the air Dryer in order to become familiar with the recommended procedures. This will minimize the possibility of personal injury or damage to the unit due to improper operation or handling.

3. Table of Contents

1. Welcome & Congratulations	3	8.10 Setting the Outlet Pressure.....	49
2. Introduction	3	8.11 Connecting to Common Alarm Terminals	49
3. Table of Contents.....	4	8.12 Connecting via Web Browser	50
4. Safety & Warning Information.....	6	8.13 Using the Status Screen	52
5. Overview & Specifications.....	9	8.14 Using the Setup Screen	54
5.1 Product Description	9	8.15 Using the Event Screen.....	56
5.2 Key Features.....	9	8.16 Using the Firmware Screen.....	57
5.3 P210WLP Series Air Dryer Models	9	8.17 Connecting via SNMP	58
5.4 Technical Specifications.....	10	9. Testing Your Dryer	59
5.5 Dryer Function Overview	11	9.1 Safety & Warning Information	59
6. Installing Your Dryer	12	9.2 Measuring Compressor Amp Draw	60
6.1 Safety & Warning Information	12	9.3 Measuring Compressor Voltage	61
6.2 Before You Begin.....	13	9.4 Measuring Incoming Voltage	62
6.3 Included Contents	14	9.5 Testing Consistent Heatless Dryer Cycling.....	63
6.4 Required Tools and Materials.....	15	9.6 Measuring Heatless Dryer Solenoid Voltage.....	64
6.5 Installation Steps.....	15	9.7 Testing Air Dryer Fan.....	65
6.6 Installation Checklist	26	9.8 Testing Compressor ON/OFF Cycling ..	66
6.7 Moving Your Dryer	26	9.9 Testing High Compressor Last Run Time Alarm	67
7. Registering Your Dryer.....	27	9.10 Testing Humidity Alarm and System Shutdown	68
8. Operating Your Dryer	28	9.11 Testing High Outlet Pressure Alarm....	70
8.1 Safety & Warning Information	28	9.12 Testing Low Outlet Pressure Alarm....	71
8.2 Connecting Air Supply Lines to the Dryer	29	9.13 Testing Air Fittings & Hoses for Leaks	72
8.3 Depressurizing the Dryer.....	30	10. Maintaining Your Dryer	74
8.4 Powering the Dryer ON & OFF.....	30	10.1 Safety & Warning Information	75
8.5 Using the Front Panel Display	31	10.2 Six Month Maintenance.....	76
8.6 Identifying Dryer Alarms	33	10.3 Annual Maintenance	77
8.7 Adjusting & Resetting Dryer Set Points	35	11. Replacement Parts & Accessories	79
8.8 Open Panel.....	47	11.1 Dryer Parts	79
8.9 Setting the System Pressure.....	48		

11.2 Dryer Parts Cont. (Circuit Board Selection).....	80	13.15 Compressor Won't Build Pressure.....	91
11.3 Heatless Dryer Assembly Parts.....	81	13.16 Compressor Excessive AMP Draw.....	91
11.4 Accessories for Your Dryer.....	82	13.17 High Compressor Last Run Time Alarm.....	92
11.5 Ordering Parts from Altec AIR.....	82	13.18 Can't Create a High Compressor Last Run Time Alarm.....	92
12. Service & Repair.....	83	13.19 Compressor Rapid ON/OFF Cycling.....	93
12.1 Services Offered.....	83	13.20 Contacting Altec AIR Technical Support.....	93
12.2 Initiating a Service Transaction.....	83	14. Appendix.....	94
13. Troubleshooting Your Dryer.....	84	14.1 Wiring Diagram.....	94
13.1 Before You Call Altec AIR.....	84	14.2 Set Point Limits and Defaults.....	95
13.2 Safety & Warning Information.....	84	14.3 SNMP Parameters.....	96
13.3 Air Dryer Won't Power ON.....	86	15. Limited Warranty Agreement.....	97
13.4 Display Screen Not Functioning.....	86	Registration Reminder.....	97
13.5 High Outlet Pressure Alarm.....	86	16. Contacting Altec AIR.....	98
13.6 Can't Create a High Pressure Alarm.....	86	16.1 General.....	98
13.7 Low Outlet Pressure Alarm.....	87	16.2 Sales.....	98
13.8 Can't Create a Low Pressure Alarm.....	87	16.3 Service.....	98
13.9 High Humidity.....	88	16.4 Technical Support.....	98
13.10 Can't Create a High Humidity Alarm / Shutdown.....	89	17. Notes.....	99
13.11 High Duty Cycle Alarm.....	89		
13.12 High Cabinet Temperature Alarm.....	89		
13.13 Inconsistent Heatless Dryer Cycling.....	90		
13.14 Compressor Doesn't Operate.....	90		

4. Safety & Warning Information

This section contains general information about safety and warning points to consider and adhere to during installation, operation, and maintenance of your Air Dryer. PLEASE READ THIS SECTION BEFORE PERFORMING ANY OPERATION OR PROCEDURE ON YOUR AIR DRYER.

Additional warnings specific to an operation or procedure will also be presented throughout the following sections. These will include the ⚠ symbol as well as a label of “**WARNING!**”, “**CAUTION!**”, or “**IMPORTANT!**”. Please be sure to pay close attention for these warnings and read them as you encounter them.



WARNING!

For your safety, all the information in this User's Guide must be followed to minimize the risk of electrical shock, and prevent property damage or personal injury.



WARNING!

Extreme care should be exercised to avoid contact with live electrical circuits. Many procedures performed during installation, operation, testing, and maintenance of this air Dryer require the equipment to be running, creating a situation for potential electrical shock. It is highly recommended that you remove all jewelry before performing any procedures.

**WARNING!**

Internal surfaces may be hot. Use care when coming into contact with internal components as there is a potential for some of these components to become hot when in operation or standby.

**WARNING!**

High Noise. PUREGAS air-dryers are meant to be installed in an unattended area.

**CAUTION!**

Proper installation & maintenance as outlined in this User's Guide is extremely important to ensure the reliability and longevity of the equipment as well as prevent damage or personal injury.

**CAUTION!**

Depressurizing the Air Dryer may be necessary before performing certain procedures. **NEVER** remove pressure sensing tubes from the Control Board without depressurizing the Air Dryer first, or **damage to the Control Board will occur.**

**CAUTION!**

Incoming power to Dryer must be:

- 15 amp service recommended
- 110 - 125 VAC, 50/60 Hz for P210WLP models
- 208 - 253 VAC, 50/60 Hz, 1 Phase for P212WLP models

**IMPORTANT!**

Performing routine maintenance as outlined in the *Maintaining Your Dryer* section will ensure optimal performance over the lifecycle of your Air Dryer.

**IMPORTANT!**

Performing procedures not described in this User's Guide or installing components not supplied by Altec AIR is **NOT RECOMMENDED AND MAY VOID THE WARRANTY.**

**CAUTION!**

This Air-dryer does not contain an internal Surge Protection Device (SPD). An SPD is required and must be supplied by the user.

**CAUTION!**

Observe precautions for handling **Electrostatic Sensitive Devices.**

**IMPORTANT!**

Installation of ALTEC AIR air-dryers are intended for network telecommunication facilities (non-customer premises) only.

5. Overview & Specifications

5.1 Product Description

The P210WLP Series Air Dryers from Altec AIR are designed to intake wet ambient air and remove the moisture for delivery to applications requiring a constant, on-demand source of dry, pressurized air. This process is fully automatic and will remain consistent with minimal required periodic maintenance. These dryers are designed specifically for indoor use.

The P210WLP Series Air Dryers employ a fully digital operating platform offering the most accurate readings of Dryer variables, removable access panel allowing easier access for adjustment and maintenance, and ultra-quiet compressor with an industry leading maintenance interval.

5.2 Key Features

- LCD display of all operating parameters
- Solid state microprocessor-based circuitry eliminates costly maintenance
- Accurate humidity sensing within $\pm 0.1\%$ RH
- Oil-less compressor

5.3 P210WLP Series Air Dryer Models

Model	Description
P210WLP	110 - 125 VAC, 0.3 – 7.5 PSI (2.1 – 51.7 KPA) Outlet Pressure
P210WLP-V	
P212WLP	208 - 253 VAC, 0.3 – 7.5 PSI (2.1 – 51.7 KPA) Outlet Pressure

5.4 Technical Specifications

	P210WLP-V	P210WLP	P212WLP
Output Capacity	Up to 200 SCFD (5.7 SCMD) @ 100% Duty Cycle		
Power Requirements	110 – 125 VAC 60 HZ		208 – 253 VAC 50 – 60 HZ
Outlet Pressure Range	0.3 – 7.5 PSI (2.1 – 51.7 KPa)		
Outlet Air Humidity	Less than 2% RH Less than -40 °F/°C Atmospheric Dew Point		
Compressor Type	Oil-less Piston Type		
Drying Method	Heatless Desiccant		
Optimal Operating Temperature Range	40° – 85° F (5° - 30° C) Ambient <i>*Unit will go into SHUTDOWN mode if Cabinet Temperature exceeds 120° F (49° C)</i>		
Alarms	Standard Alarms - Complete readings of all critical measurement points, individual alarm indication display, including SNMP Communication		
Outlet Connections	3/8" Press-to-lock Fitting		
Dimensions	6.75" D x 16.13" W x 19.39" H	19.39" D x 16.13" W x 6.75" H (49.27 cm D x 40.97 cm W x 17.15 cm H)	
Net Weight	42 lbs (19 kgs)		

5.5 Dryer Function Overview

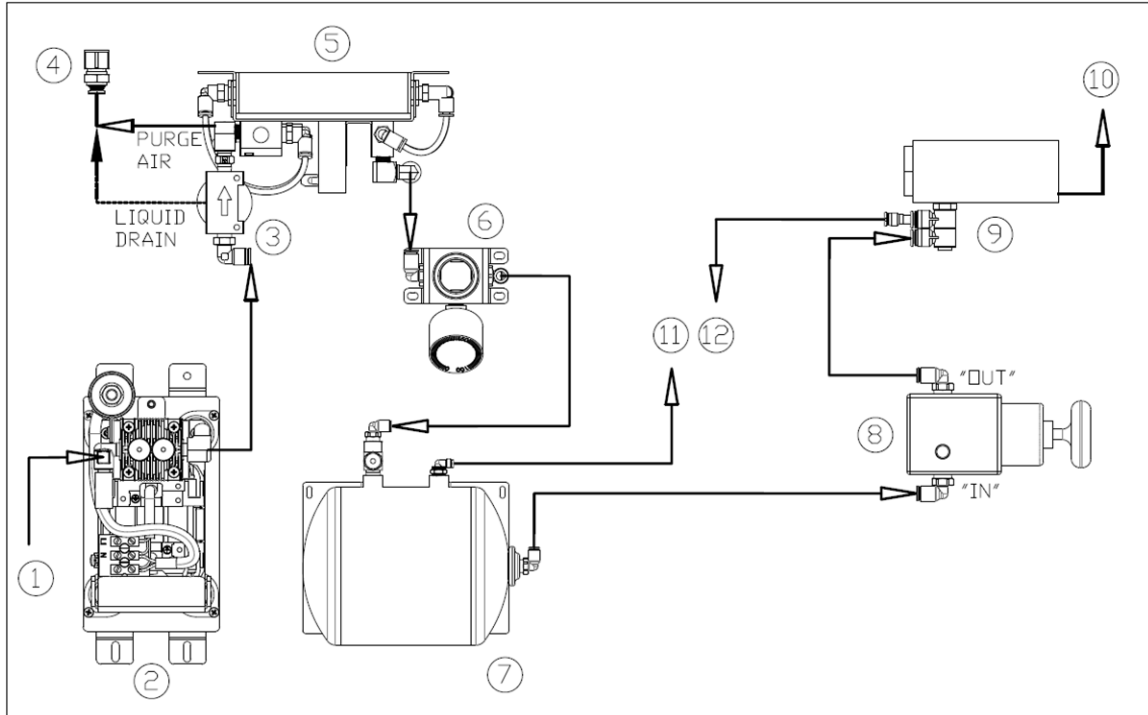

#	Component	Description
1	Inlet Muffler	Minimizes compressor intake noise
2	Compressor	Compresses air drawn in by the inlet muffler
3	Coalescing Filter	Removes liquid water droplets from the airstream prior to the heatless dryer
4	Purge Outlet	Outputs heatless dryer purge air and the liquid water from the coalescing filter
5	Heatless Dryer	Removes moisture from the compressed air.
6	Capacity Control Valve	Regulates system pressure and prevents air from bleeding back through the heatless dryer.
7	Air Tank	Stores compressed dry air.
8	Outlet Pressure Regulator	Regulates the outlet pressure to the desired outlet condition.
9	Humidity Sensor	Measures the humidity of the compressed air.
10	System Outlet	Outputs the tank air at the pressure set by the outlet pressure regulator
11	Tank Pressure Transducer	Interprets tank pressure for display
12	Outlet Pressure Transducer	Interprets outlet pressure for display

6. Installing Your Dryer

6.1 Safety & Warning Information



WARNING!

Internal surfaces may be hot. Use care when coming into contact with internal components as there is a potential for some of these components to become hot when in operation or standby.



WARNING!

Extreme care should be exercised to avoid contact with live electrical circuits. Many procedures performed during installation, operation, testing, and maintenance of this Air Dryer require the equipment to be running, creating a situation for potential electrical shock. It is highly recommended that you remove all jewelry before performing any procedures.



WARNING!

High Noise. Air-dryers are meant to be installed in an unattended area.



CAUTION!

Proper installation & maintenance as outlined in this User's Guide is extremely important to ensure the reliability and longevity of the equipment as well as prevent damage or personal injury.



CAUTION!

This Air-dryer does not contain an internal Surge Protection Device (SPD). An SPD is required and must be supplied by the user.

**CAUTION!**

Incoming power to Dryer must be:

- 15 amp service recommended
- 110 - 125 VAC, 50/60 Hz for P210WLP models
- 208 - 253 VAC, 50/60 Hz, 1 Phase for P212WLP models

**IMPORTANT!**

Performing procedures not described in this User's Guide or installing components not supplied by Altec AIR is **NOT RECOMMENDED AND MAY VOID THE WARRANTY.**

**IMPORTANT!**

Installation of PUREGAS air-dryers are intended for network telecommunication facilities (non-customer premises) only.

6.2 Before You Begin

6.2.1 Carefully inspect the unit, including the shipping box as well as the air Dryer, for ANY DAMAGE CAUSED BY SHIPPING. If any shipping damage is detected, it is important to file a claim with the shipping company prior to continuing the installation procedures.

6.2.2 Read the entire *Installing Your Dryer* section to familiarize yourself with the components and procedures before performing the air Dryer installation.

6.2.3 Verify the installation location of the air Dryer:

6.2.3.1 Well ventilated and free from abrasive dust or chemicals.

6.2.3.2 Ambient temperature is between 40° and 85° F (5° and 30° C) for optimal performance

NOTE: Higher temperatures will decrease component lifespan.

6.2.3.3 Meets the following power requirements:

- 110 - 125 VAC for P210WLP models
- 208 - 253 VAC, 1 Phase for P212WLP models
- All models require 50/60 Hz and minimum 15 amp service

6.2.4 Notify the alarm center of the installation and potential for alarms during the process (as necessary).

6.3 Included Contents

- (1) P210WLP Series Air Dryer
- (1) 120 VAC Power Cord (P210WLP models)
- (1) 220 VAC Power Cord (P212WLP models)
- (4) Connector, Male 1/4 MPT Swivel Elbow
- (1) Precision Bleed Orifice Fitting
- (1) Rack Mounting U-shaped Bracket (P210WLP-V Excluded)
- (2) Rack Mounting Ear Brackets (P210WLP-V Excluded)
- (1) Drawer Slide Pair (P210WLP-V Excluded)
- (2) Vertical Wall Mount Bracket (P210WLP-V Only)
- (1) User's Guide (not shown)
- (1) Installation Hardware Kit
- (1) 36" Purge Drain Tube

6.4 Required Tools and Materials

- Medium adjustable wrench
- Phillips Head Screwdriver
- Box Cutter
- Loctite 222MS
- Cup of soapy water
- 1-inch paint brush (recommended)

6.5 Installation Steps

6.5.1 Using a box cutter remove the Dryer from box and all shipping materials.

NOTE: If ANY SHIPPING DAMAGE is detected, file a claim with the shipping company prior to continuing the installation procedures.

6.5.2 Open panel latches and remove the top panel.

NOTE: The top panel is equipped with locking latches if a higher level of security is required

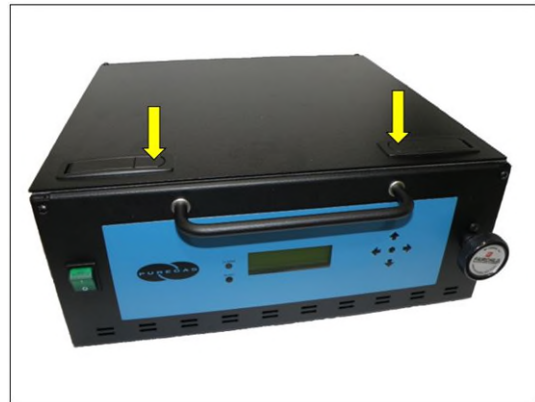

6.5.3 Check for loose parts, hoses, or wiring.

NOTE: If ANY SHIPPING DAMAGE is detected, file a claim with the shipping company prior to continuing the installation procedures.

- 6.5.4** Remove the wooden shipping block from the compressor assembly by removing the single #8-32 x 3/4" Philips head screw and pulling the block free.

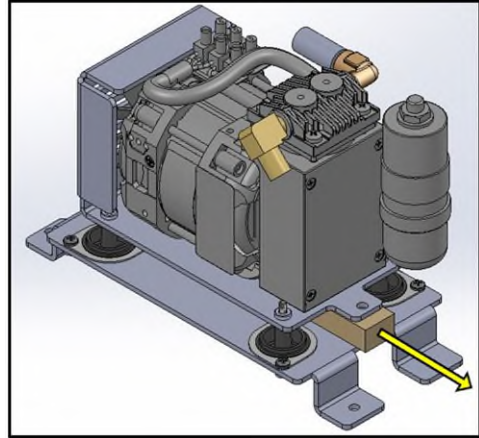

NOTE: Do not discard shipping block. Shipping block must be re-inserted in the case of a future event requiring movement of the dryer (See section 6.7)

- 6.5.5** Remove the plastic plug from the purge port



- 6.5.6** Remove the metal plug from the outlet port. Install the plug into the included precision bleed orifice fitting and then into the dryer Outlet Port.



6.5.7 For **RACK MOUNT** installations (*See sections 6.5.8 & 6.5.9 for wall mount installations*):

6.5.7.1 Extend the drawer slide brackets and separate into two components by pressing down on the black lever and pulling apart.

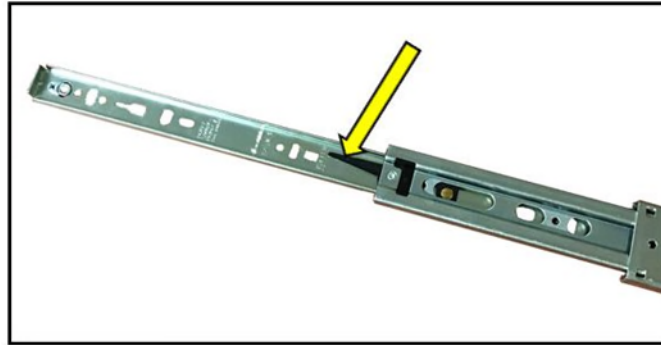

6.5.7.2 Install the smaller of the two slide components on the side panels of the unit by inserting two of the supplied 8-32 x 5/16" screws into the pre-threaded holes on each side of the unit. Use loctite to secure the screws.

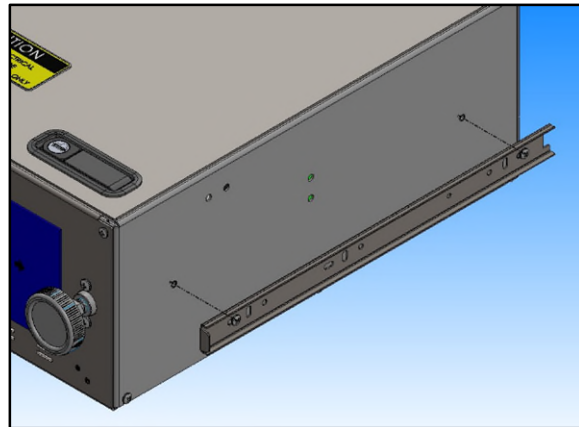

6.5.7.3 Install the larger of the two slide components on the inside walls of the provided U-shaped mounting bracket by inserting two of the supplied 10-32 x 3/8" screws on each side. Use Loctite to secure the screws.

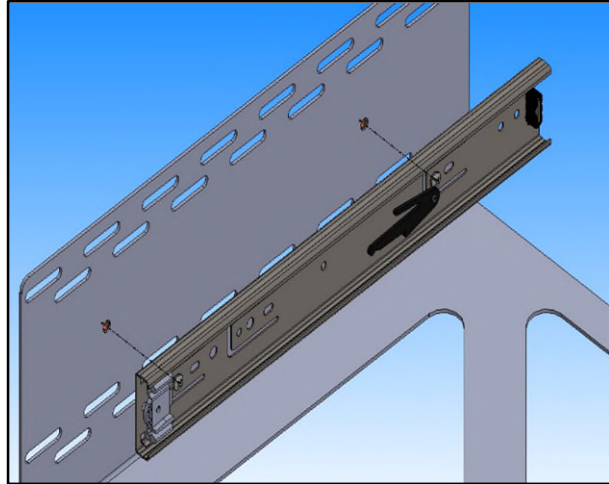

6.5.7.4 Install one of the "mounting ear" brackets on each side of the U-shaped mounting bracket using two 10-32 x 5/8" screws, two washers, and two 10-32 Nylock nuts.

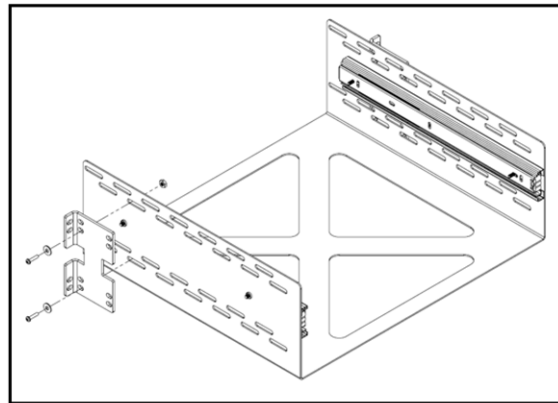

NOTE: The mounting ears are reversible to accommodate both 19" and 23" racks. The mounting ears can be installed in various positions along the depth of the U-shaped bracket to accommodate various rack configurations.

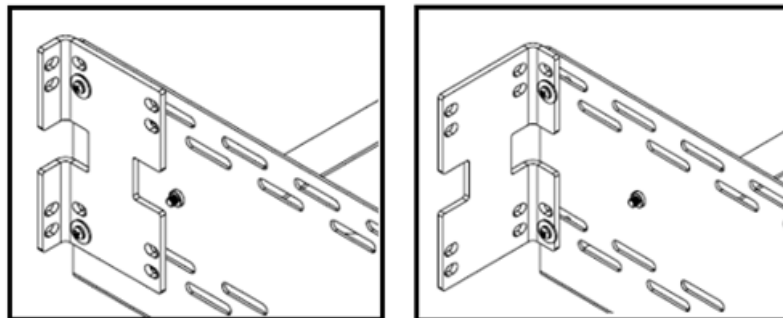

6.5.7.5 Install the U-shaped bracket assembly into the server rack by bolting the two mounting ear brackets to the rails of the rack. Refer to the manufacturer of the server rack to determine the hardware necessary for component installation.

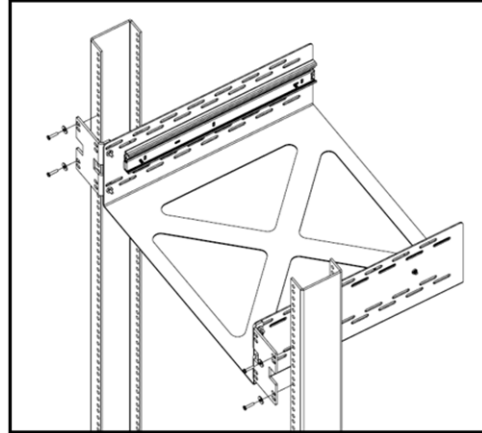

NOTE: If the server rack has additional mounting rails, an additional set of mounting ears can be used to decrease unit sway (*see section 11.4 for ordering information*).

6.5.7.6 From a supported position, lift and slide the unit into the U-shaped bracket assembly that is installed in the server rack. Take care to align the drawer slide components so that they engage correctly with each other. Firmly push the unit until it is fully installed, and the drawer slides will lock to prevent accidental separation.

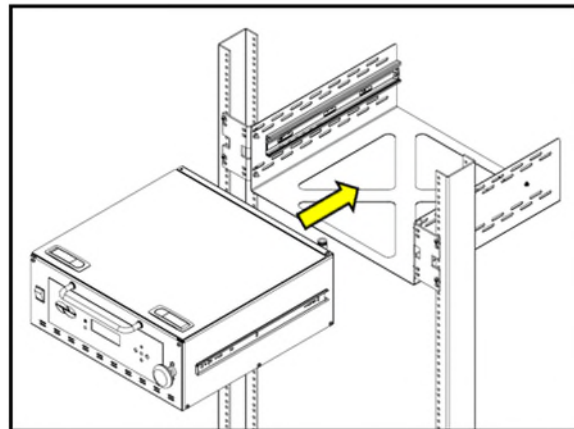

NOTE: The unit can be quickly removed from the U-shaped bracket assembly without removal of mounting hardware by fully extending the unit, pressing down on the black release levers on the drawer slides (*See section 6.5.7.1 for detail*), and gently pulling the unit free.

6.5.8 For **HORIZONTAL WALL MOUNT** installation (*See section 6.5.7 for rack mount installation & section 6.5.9 for vertical wall mount installation*)

6.5.8.1 Each P210WLP Series dryer, excluding P210WLP-V dryers, is shipped with a standard rack mount installation kit. *Section 10.3* outlines the general installation process for wall mounting a P210WLP Series dryer. The installation components required for wall mounting are **NOT INCLUDED** with the standard dryer (*see section 11.4 for ordering information*).

6.5.8.2 Install a wall mount bracket on each side panel of the unit using two 8-32 x 3/8" screws and two washers. Use Loctite to secure the screws.

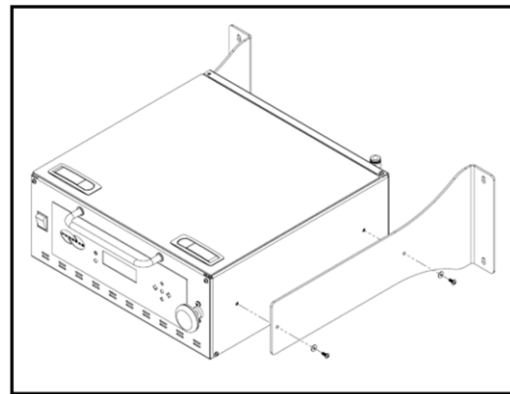

6.5.8.3 Refer to the following hole pattern to locate fasteners on the wall:

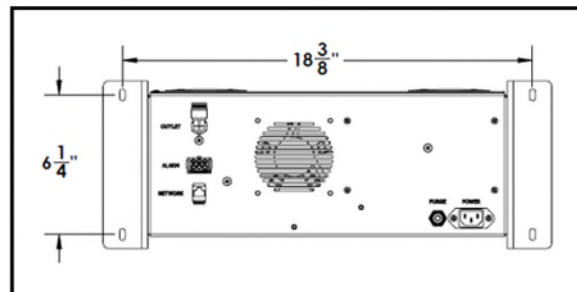

6.5.8.4 Refer to the fastener manufacturer for installation instructions of wall anchors. The minimum necessary fastener tensile/pullout strength is 2,000 pounds per anchor.

6.5.9 For **VERTICAL WALL MOUNT** installations – P210WLP-V units only (*See section 6.5.7 for rack mount installations & section 6.5.8 for horizontal wall mount installations*):

NOTE: This section is only applicable for P210WLP-V model units. All other P210WLP series dryers **MUST** be mounted in a horizontal orientation.

6.5.9.1 Each P210WLP-V dryer is shipped with a standard vertical wall mount installation kit. *Section 6.5.9* outlines the general installation process for wall mounting a P210WLP-V dryer.

6.5.9.2 Install a wall mount bracket on each side panel of the unit using two 8-32 x 3/8" screws and two washers. Use Loctite to secure the screws.

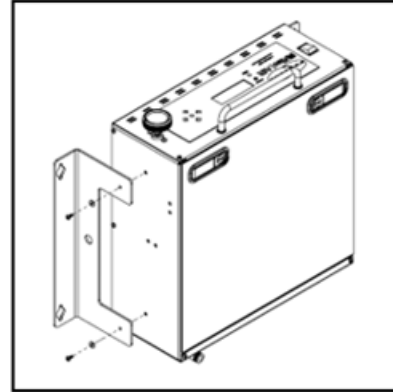

6.5.9.3 Refer to the following hole pattern to locate fasteners on the wall:

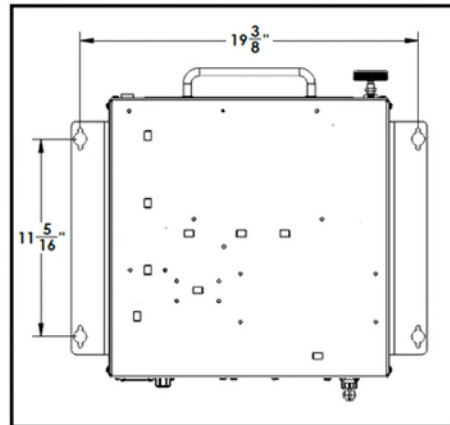

6.5.9.4 Refer to the fastener manufacturer for installation instructions of wall anchors. The minimum necessary fastener tensile/pullout strength is 2,000 pounds per anchor.

6.5.9.5 Ensure that the unit is mounted with the display facing upwards

6.5.10 Verify that the Dryer is powered **OFF**.

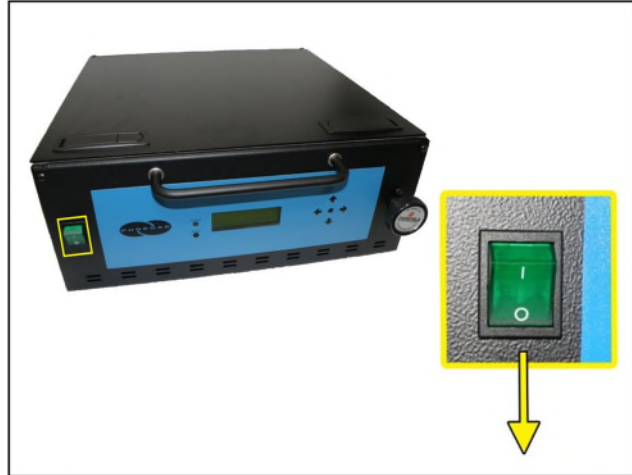

6.5.11 Plug AC Power Cord to Dryer.

6.5.12 Wire or plug the power cord into:

- 110 - 125 VAC power outlet for the P210WLP model
- 208 - 253 VAC, 1 phase, power outlet for the P212WLP models
 - Line – Black (Brown)
 - Neutral – White (Blue)
 - Ground – Green (Green/Yellow)



6.5.13 Power the Dryer **ON**.

NOTE: The compressor and heatless Dryer will start, creating air flow through the Outlet Port.



6.5.14 Set the System Pressure:**With Compressor running:**

6.5.14.1 Pull the Capacity Control Valve knob out.

6.5.14.2 Turn the knob until the reading on the pressure gauge is **50 PSI**.

6.5.14.3 Push the knob in to lock.

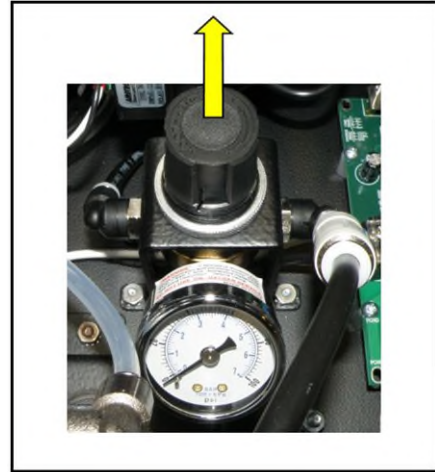

6.5.15 Let the Dryer run until the Humidity drops below 2%. (may take up to 15 minutes).

NOTE: Press the **RESET** button if the Dryer goes into **SHUTDOWN** mode.



6.5.16 Power the Dryer **OFF**.

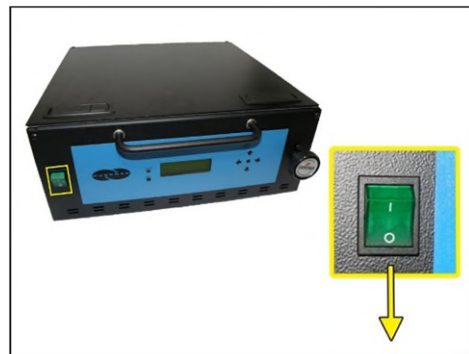

6.5.17 Remove the Precision Bleed Orifice fitting from the Outlet Port by pressing the ferrule down then pulling the fitting upward.

NOTE: Save this fitting for use in low flow applications. It is recommended that the dryer operates with a duty cycle of 10% or greater.



6.5.18 Connect a 3/8" air supply line to the Outlet Port.

NOTE: For all dryers with minimal flow, install the Precision Bleed Orifice fitting to maintain a constant flow of air.



6.5.19 Power the Dryer ON.



6.5.20 Set the Outlet Pressure:

6.5.20.1 Loosen the retaining nut and turn knob until Outlet Pressure (OUTP) reading is at the desired setting.

6.5.20.2 Tighten the retaining nut to lock the knob in place.

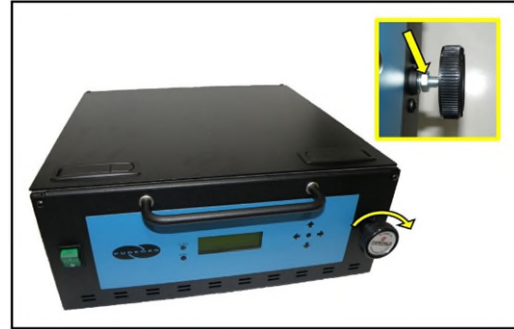

6.5.21 Check for air leaks:

NOTE: This is a general procedure that can be applied to any fitting or hose that has air pressure in it. **DO NOT SOAP TEST THE HUMIDITY SENSOR FITTING. DAMAGE TO THE SENSOR MAY OCCUR.**

With Compressor NOT running:

6.5.21.1 Listen for any 'hissing' sounds which may indicate a fitting or hose air leak.

With Compressor running:

6.5.21.2 Use a 1-inch paint brush to dab soapy water on the air fitting or hose connection to be tested.

If air bubbles appear at the connection, this indicates that air is leaking from the connection.

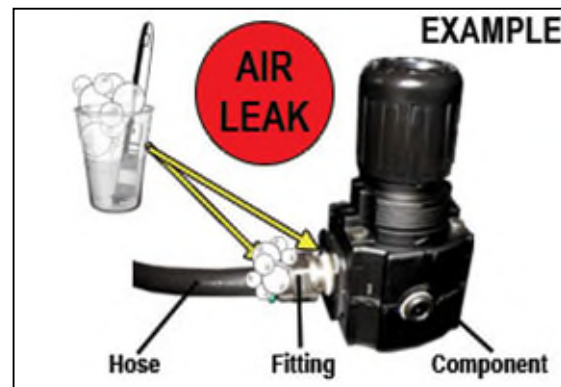

If any leaks are detected, take steps to seal them off (as necessary):

- *Tighten the fitting*
- *Re-connect the hose end*
- *Replace the fitting / hose / component*

6.5.22 Re-install the top panel and fasten the latches.

6.5.23 REGISTER YOUR DRYER. See section 7. for details.

6.6 Installation Checklist

- No shipping damage was detected.
- Dryer location meets the following requirements:
 - Well ventilated
 - Free from abrasive dust or chemicals
 - Ambient temperature is between 40° – 85° F (5° - 30° C) for optimal performance
- System Pressure is set to 50 PSI.
- No air leaks are present in the system.
- No alarms are present on the Display Panel.

6.7 Moving Your Dryer

6.7.1 If relocating your dryer to another site of operation or packaging to ship for service, perform the following steps prior to movement to ensure your dryer continues to operate optimally.

6.7.1.1 Return the shipping block to the compressor assembly by re-inserting the block between the compressor brackets and re-inserting the #8-32 x ¾" screw (*See section 6.5.4 for reference*).

6.7.1.2 Remove any visible liquid water in the coalescing filter by unscrewing the filter bowl and dumping the water. This process may be made easier by removing the unit side panel.

NOTE: Take care not to pinch the o-ring seal while returning the filter bowl to the filter housing assembly

7. Registering Your Dryer

Please take a moment to register your PUREGAS P210WLP Series Air Dryer. Registering is necessary to activate the Limited Warranty on your product. Once you register, you are eligible to receive free technical support, as well as updates concerning your Altec AIR products.

Register Online at <http://www.AltecAIR.com/registration.html>

Or by Phone 1-800-521-5351 (option 2)

Have the following information available:

Model #: _____ **Serial #:** _____

Company Name: _____ **Location Name:** _____

Shipping Address: _____

City: _____ **State:** _____ **Zip Code:** _____

Contact Name: _____ **Phone #:** () - ext. _____

Email: _____

8. Operating Your Dryer

8.1 Safety & Warning Information



WARNING!

Extreme care should be exercised to avoid contact with live electrical circuits. Many procedures performed during installation, operation, testing, and maintenance of this Air Dryer require the equipment to be running, creating a situation for potential electrical shock. It is highly recommended that you remove all jewelry before performing any procedures.



WARNING!

Internal surfaces may be hot. Use care when coming into contact with internal components as there is a potential for some of these components to become hot when in operation or standby.



WARNING!

High Noise. ALTEC AIR air-dryers are meant to be installed in an unattended area.



CAUTION!

Observe precautions for handling **Electrostatic Sensitive Devices.**



IMPORTANT!

Performing procedures not described in this User's Guide or installing components not supplied by Altec AIR is **NOT RECOMMENDED AND MAY VOID THE WARRANTY.**

8.2 Connecting Air Supply Lines to the Dryer

8.2.1 Connect a 3/8" air supply line to the Outlet Port.

NOTE: For all dryers with minimal flow, install the Precision Bleed Orifice fitting to maintain a constant flow of air.



8.2.2 Power the Dryer ON.



⚠ CAUTION: Be careful when removing outlet plugs or connected Air Supply Lines. System may be pressurized.

8.3 Depressurizing the Dryer

8.3.1 To prevent pressure from building back up, power the dryer **OFF** (*See section 8.4 for detail*).

8.3.2 Open Top Panel

8.3.3 Pull the ring handle on the air tank until all the air pressure is released.

8.3.4 Close Top Panel

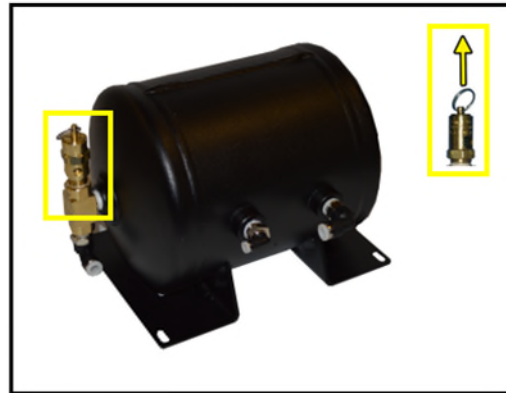

8.4 Powering the Dryer ON & OFF



CAUTION!

Incoming power to Dryer must be:

- 15 amp service recommended
- 110 - 125 VAC, 50/60 Hz for P210WLP models
- 208 - 253 VAC, 50/60 Hz, 1 Phase for P212WLP models

8.4.1 POWER Switch -

Controls the main power to the Dryer.



8.5 Using the Front Panel Display



CAUTION!

The Display Screen is covered by a clear protective layer that guards against Electrostatic Discharge (ESD). **DO NOT REMOVE THIS LAYER.**

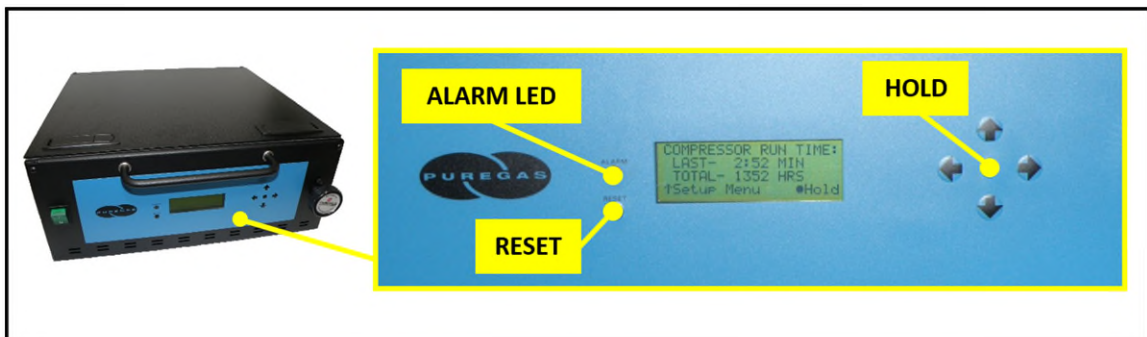

8.5.1 ALARM LED – Indicates an alarm is present.

8.5.2 RESET Button – Clears an alarm and allows the system to continue operating.

8.5.3 HOLD Button – Freezes the current information screen on the display. When pressed again, it will allow the information screens to begin cycling again.

8.5.4 Arrow Buttons – Used to access, navigate, and change values in the Set Point Adjust screens.

8.5.5 Display Screen - Shows the current Dryer readings. Will cycle between the following information screens (unless the **HOLD** button has been pressed):

8.5.5.1 Tank Screen

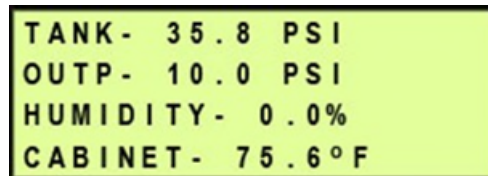

```
TANK - 35.8 PSI
OUTP - 10.0 PSI
HUMIDITY - 0.0%
CABINET - 75.6°F
```

TANK – Air Tank pressure - fluctuates between 20 – 50 PSI (137.9 – 344.7 KPa).

OUTP – Outlet Pressure regulated by the Outlet Pressure Regulator

HUMIDITY – Humidity level of the system.

CABINET – Temperature of the Dryer cabinet compartment.

8.5.5.2 System Stat Screen

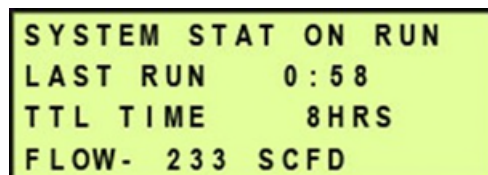

```
SYSTEM STAT ON RUN
LAST RUN 0:58
TTL TIME 8HRS
FLOW - 233 SCFD
```

SYSTEM STAT - Running Status of the system:

- **ON RUN** – System is Online.
- **SHUTDOWN** – System has been shut down as a result of either a Humidity or High Cabinet Temperature alarm.

LAST RUN – How many minutes the compressor ran during the last Air Tank pressurization cycle.

TTL TIME – How many hours the compressor has run since the last Comp Run Reset.

FLOW – Air Flow Rate

8.6 Identifying Dryer Alarms

8.6.1 High Outlet Pressure Alarm -

Occurs when the Outlet Pressure (**OUTP**) rises above the alarm set point for more than one (1) minute.

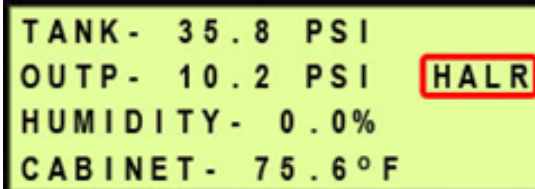

TANK - 35.8 PSI
 OUTP - 10.2 PSI **HALR**
 HUMIDITY - 0.0%
 CABINET - 75.6 °F

(Default setting is 10.0 PSI (68.9 KPa) for Standard models / 7.50 PSI (51.7 KPa) for LP models)

See section 13.5 for troubleshooting information.

8.6.2 Low Outlet Pressure Alarm –

Occurs when the Outlet Pressure (**OUTP**) drops below the alarm set point for more than one (1) minute.

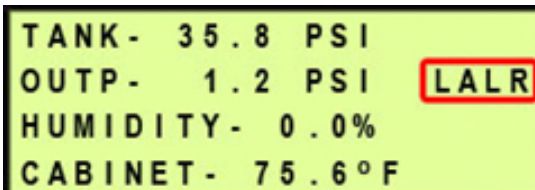

TANK - 35.8 PSI
 OUTP - 1.2 PSI **LALR**
 HUMIDITY - 0.0%
 CABINET - 75.6 °F

(Default setting is 2.0 PSI (13.8 KPa) for Standard models / 0.30 PSI (2.1 KPa) for LP models)

See section 13.7 for troubleshooting information.

8.6.3 High Humidity Alarm –

Occurs when the Humidity level rises above the alarm set point for more than one (1) minute. (Default setting is 10.0%)

```
TANK - 35.8 PSI
OUTP - 10.0 PSI
HUMIDITY - 10.2% ALR
CABINET - 75.6 °F
```

If this alarm is present for one (1) minute or more, the air Dryer will go into **SHUTDOWN** mode to prevent saturated air from being delivered to the supply line.

See section 13.9 for troubleshooting information.

8.6.4 High Cabinet Temperature Alarm -

Occurs when the temperature in the cabinet rises above 120°F (49°C) for more than ten (10) seconds.

```
TANK - 35.8 PSI
OUTP - 10.0 PSI
HUMIDITY - 10.2%
CABINET - 144.1 °F ALR
```

If this alarm is present for three (3) minutes or more, the Compressor will **SHUTDOWN** to protect against damage due to overheating. Once the temperature lowers to 112°F (44°C) the Compressor will re-start.

See section 13.12 for troubleshooting information.

8.6.5 High Compressor Last Run Time Alarm –

Occurs when the compressor takes longer to pressurize the air tank than the set point for the alarm. (Default setting is 3:00 minutes)

```
SYSTEM STAT ON RUN
LAST RUN 3:52 ALR
TTL TIME 8HRS
FLOW - 233 SCFD
```

See section 13.17 for troubleshooting information.

8.6.6 Compressor Total Hour Alarm –

Occurs when the compressor has reached an 8,000-hour maintenance interval. Perform the required maintenance.

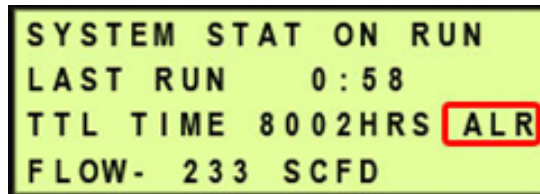

```

SYSTEM STAT ON RUN
LAST RUN      0:58
TTL TIME     8002HRS ALR
FLOW- 233 SCFD
  
```

See section 10.3 for maintenance information.

8.6.7 High Flow Rate Alarm –

Occurs when the Flow Rate (FLOW) rises above the alarm set point for more than one (1) minute. (Default setting is 500 SCFD (14.2 SCMD))

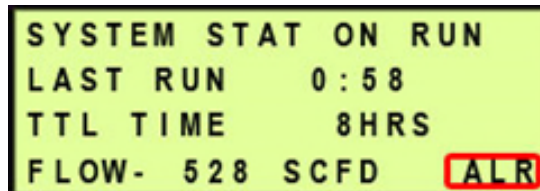

```

SYSTEM STAT ON RUN
LAST RUN      0:58
TTL TIME      8HRS
FLOW- 528 SCFD ALR
  
```

8.7 Adjusting & Resetting Dryer Set Points

Dryer Set Points are simply limits programmed for a specific reading. Once this limit is reached (or exceeded) this results in an alarm for that reading. Each of these set points is factory programmed with a default value based on typical usage of the air Dryer. Many of the set points for Dryer alarms can be modified to levels more closely based upon your specific application.

NOTE: Reference Appendix Section 14.2 for Limits and Defaults.

- Press the Up (↑) Arrow Button to access the Set Point Adjust screens.
- Press the Up (↑) & Down (↓) Arrow Buttons to navigate through the available Set Point Adjust screens.
- To change a specific Set Point:

8.7.1 High Flow Rate Alarm Set Point (default setting is 500 SCFD (14.2 SCMD)) –

8.7.1.1 Press the Right (→)

Arrow Button to access the Change Value Screen.

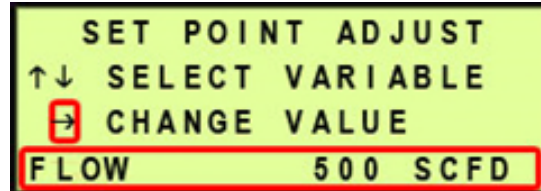
**8.7.1.2** Press the Right (→) &

Left (←) Arrow Buttons to move the underscore beneath the digit to change.

**8.7.1.3** Press the Up (↑) & Down (↓) Arrow Buttons to change the value of the selected digit.**8.7.1.4** Press the Right (→) Arrow Button until the underscore disappears.**8.7.1.5** Press the Right (→)

Arrow Button until the underscore appears under the correct setting (YES or NO).

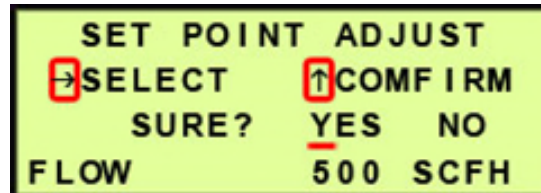
**8.7.1.6** Press the Up (↑) Arrow to confirm. This will lock in the new setting value.**8.7.2 High Outlet Pressure Alarm Set Point –**

(default setting is 10.0 PSI (68.9 KPa) for Standard models / 7.50 PSI (51.7 KPa) for LP models) –

8.7.2.1 Press the Right (→)

Arrow Button to access the Change Value Screen.

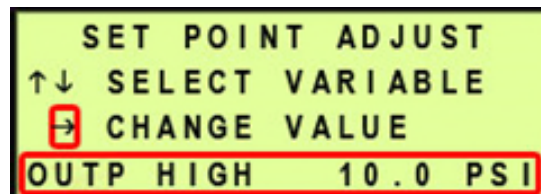
**8.7.2.2** Press the Right (→) &

Left (←) Arrow Buttons to move the underscore beneath the digit to change.

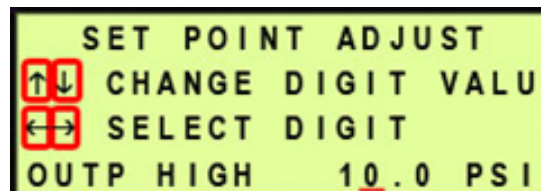

8.7.2.3 Press the Up (↑) & Down (↓) Arrow Buttons to change the value of the selected digit.

8.7.2.4 Press the Right (→) Arrow Button until the underscore disappears.

8.7.2.5 Press the Right (→) Arrow Button until the underscore appears under the correct setting (YES or NO).

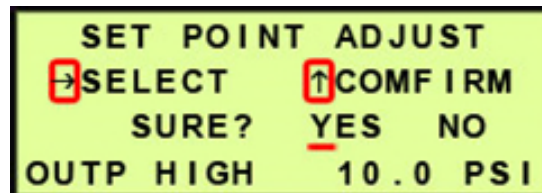

8.7.2.6 Press the Up (↑) Arrow to confirm. This will lock in the new setting value.

8.7.3 Low Outlet Pressure Alarm Set Point –

(default setting is 2.0 PSI (13.8 KPa) for Standard models / 0.30 PSI (2.1 KPa) for LP models) –

8.7.3.1 Press the Right (→) Arrow Button to access the Change Value Screen.

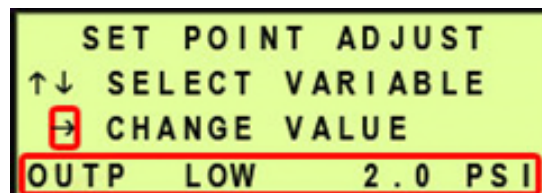

8.7.3.2 Press the Right (→) & Left (←) Arrow Buttons to move the underscore beneath the digit to change.

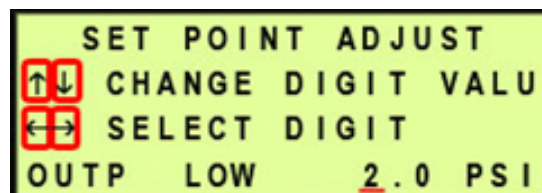

8.7.3.3 Press the Up (↑) & Down (↓) Arrow Buttons to change the value of the selected digit.

8.7.3.4 Press the Right (→) Arrow Button until the underscore disappears.

8.7.3.5 Press the Right (→) Arrow Button until the underscore appears under the correct setting (YES or NO).

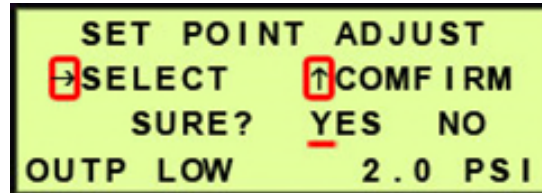

8.7.3.6 Press the Up (↑) Arrow to confirm. This will lock in the new setting value.

8.7.4 High Humidity Alarm Set Point (default setting is 10.0%) –

8.7.4.1 Press the Right (→) Arrow Button to access the Change Value Screen.

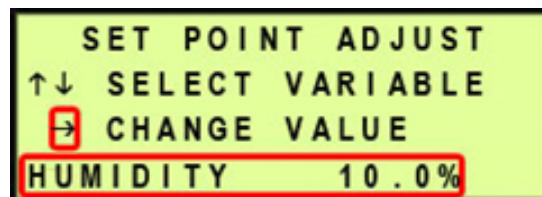

8.7.4.2 Press the Right (→) & Left (←) Arrow Buttons to move the underscore beneath the digit to change.

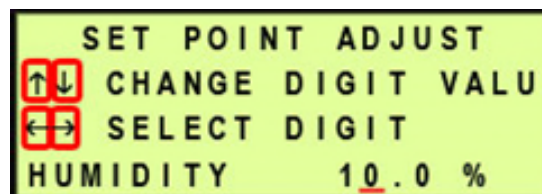

8.7.4.3 Press the Up (↑) & Down (↓) Arrow Buttons to change the value of the selected digit.

8.7.4.4 Press the Right (→) Arrow Button until the underscore disappears.

8.7.4.5 Press the Right (→) Arrow Button until the underscore appears under the correct setting (YES or NO).

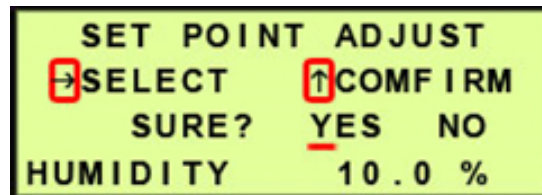

8.7.4.6 Press the Up (↑) Arrow to confirm. This will lock in the new setting value.

8.7.5 High Compressor Last Run Time Alarm Set Point (default setting is 3:00 minutes) –

8.7.5.1 Press the Right (→) Arrow Button to access the Change Value Screen.

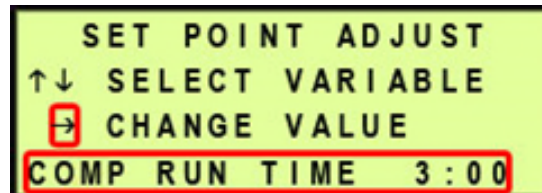

8.7.5.2 Press the Right (→) & Left (←) Arrow Buttons to move the underscore beneath the digit to change.

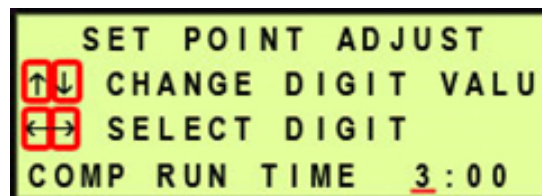

8.7.5.3 Press the Up (↑) & Down (↓) Arrow Buttons to change the value of the selected digit.

8.7.5.4 Press the Right (→) Arrow Button until the underscore disappears.

8.7.5.5 Press the Right (→) Arrow Button until the underscore appears under the correct setting (YES or NO).

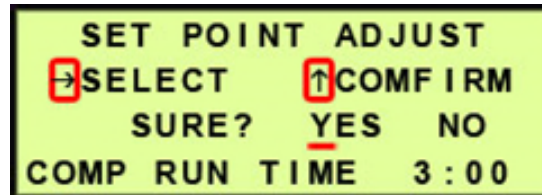

8.7.5.6 Press the Up (↑) Arrow to confirm. This will lock in the new setting value.

8.7.6 Compressor Total Time Reset –

The Total Time (**TTL TIME**) is the time the compressor runs measured in hours since startup or the last time the compressor time counter was reset. The dryer will display an alarm when this counter has reached 8,000 hours, signaling is it time for maintenance.

8.7.6.1 Press and Hold the Left (←) & Right (→) Arrow Buttons to access the Change Value Screen.

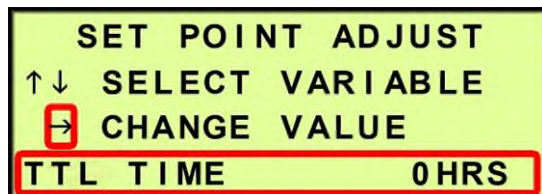

8.7.6.2 Press the Right (→) & Left (←) Arrow Buttons to move the underscore

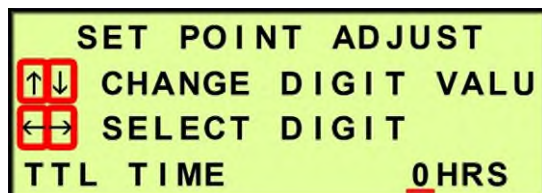

beneath the digits to change to zero (0).

8.7.6.3 Press the Up (↑) & Down (↓) Arrow Buttons to change the value of the selected digit.

8.7.6.4 Press the Right (→) Arrow Button until the confirmation screen appears.

8.7.6.5 Press the Right (→) Arrow Button until the underscore appears under the correct setting (YES or NO).

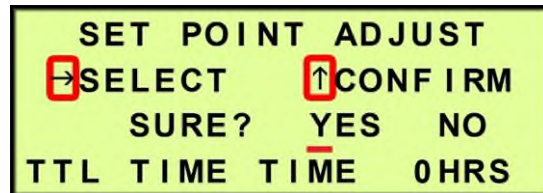

8.7.6.6 Press the Up (↑) Arrow to confirm. This will lock in the new setting value.

8.7.7 System Units–

8.7.7.1 Press and hold the Left Arrow (←) . While holding the Left Arrow (←), press and release the Down arrow (↓). This will open the “Set Model Number” menu.

8.7.7.2 Navigate to the model selection menu by pressing the right arrow (→).

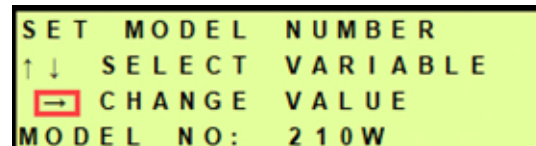

8.7.7.3 The models types listed determine the units that are displayed. Models that begin with “W2” will display Metric units, while units that begin with “W” will display Imperial Units.

8.7.7.4 Using the Right arrow

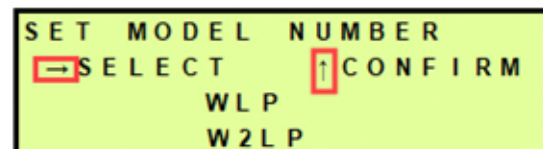

select your model with your desired units. To confirm your model selection press the Up Arrow (↑).

NOTE: For this unit the only available options are “WLP” and “W2LP”

8.7.8 Reset to Factory Values –

8.7.8.1 Press the Left (←) & Right (→) Arrow Buttons at the same time.

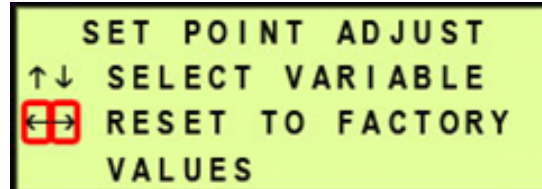

8.7.8.2 Press the Right (→) Arrow Button until the underscore appears under the correct setting (YES or NO).

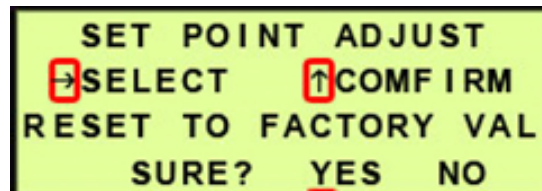

8.7.8.3 Press the Up (↑) Arrow to confirm. This will lock in the new setting value.

8.7.9 Alarm Delays Set Point –

The Alarm Delay allows the Dryer to come out of the alarm condition on its own without signaling an alarm.

ON (default) – waits one (1) minute before signaling alarms

OFF – signals alarms immediately

8.7.9.1 Press the Right (→) Arrow Button to change the value.

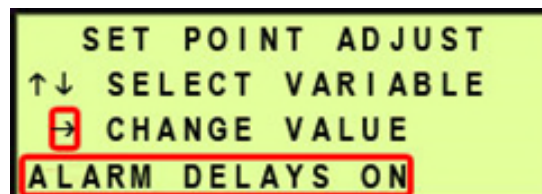

8.7.9.2 Press the Right (→)

Arrow Button until the underscore appears under the correct setting (OFF or ON).

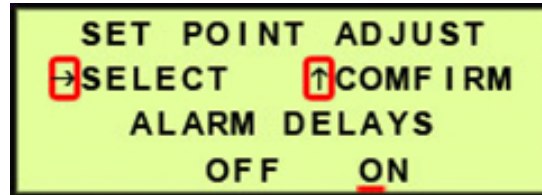

8.7.9.3 Press the Up (↑) Arrow to confirm. This will lock in the new setting value.

8.7.10 Startup Delay Set Point (default setting is 0 sec) –

The Startup Delay keeps the compressor from turning on immediately when the dryer is powered on for up to 10 seconds. This allows multiple dryers to power on in separate intervals in case of a power loss.

8.7.10.1 Press the Right (→)

Arrow Button to access the Change Value Screen.

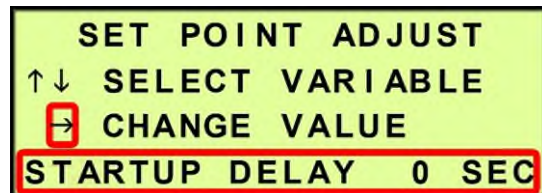
**8.7.10.2** Press the Right (→) &

Left (←) Arrow Buttons to move the underscore beneath the digit to change.

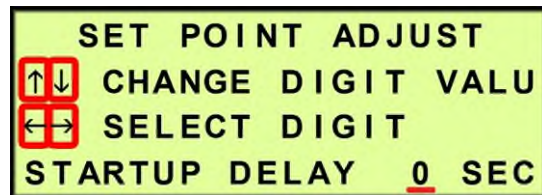

8.7.10.3 Press the Up (↑) & Down (↓) Arrow Buttons to change the value of the selected digit.

8.7.10.4 Press the Right (→) Arrow Button until the underscore disappears.

8.7.10.5 Press the Right (→)

Arrow Button until the underscore appears under the correct setting (YES or NO).

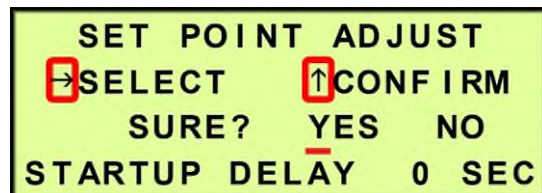

8.7.10.6 Press the Up (↑) Arrow to confirm. This will lock in the new setting value.

8.7.11 Pressure Gauge –

This is an information screen only and will not time-out, returning to the cycling information screens. It also masks air Dryer alarms while in use. This screen can be used during air Dryer troubleshooting.

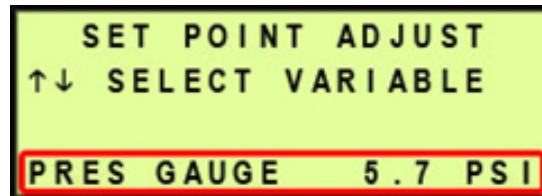
**In the Setup Menu:**

8.7.12 Press the and hold the Left Arrow (←) . While holding the Left Arrow (←), press and release the Down arrow (↓). This will open the “Set Model Number” menu.

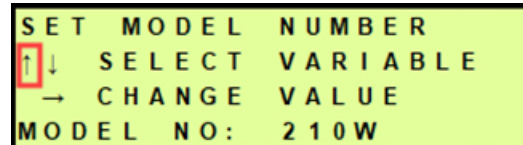

8.7.12.1 Press the Up (↑) Arrow to access various Network Settings.

8.7.13 Set IP Address (default is 192.168.1.100)

8.7.13.1 Press the Right (→) Arrow Button to access the edit screen.

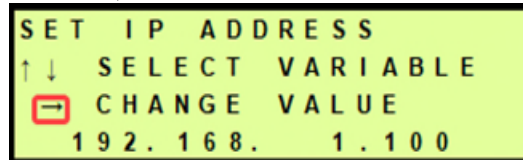

8.7.13.2 Press the Left (←) & Right (→) Arrow Buttons to Select the digit to change.

8.7.13.3 Press the Up (↑) & Down (↓) Arrow Buttons to Change the value of the selected digit.

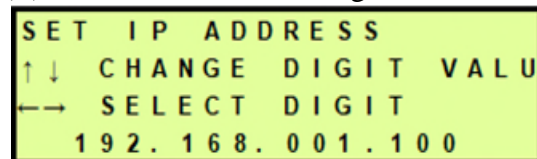

8.7.13.4 When desired value is displayed, press the Right (→) Arrow Button until the confirmation screen appears.

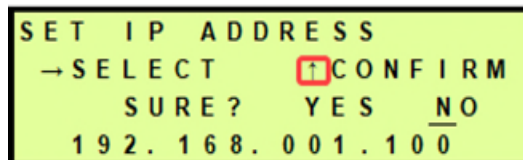

8.7.13.5 Press the Right (→) Arrow Button to Select the correct choice (Yes or No).

8.7.13.6 Press the Up (↑) Arrow to confirm the selected choice. This will lock in the new setting.

8.7.14 Set Subnet Mask (default is 255.255.255.000) –

8.7.14.1 Press the Right (→) Arrow Button to access the edit screen.

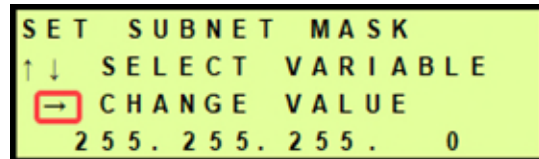

8.7.14.2 Press the Left (←) & Right (→) Arrow Buttons to Select the digit to change.

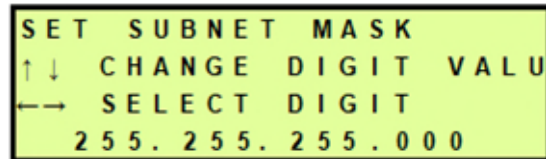

8.7.14.3 Press the Up (↑) & Down (↓) Arrow Buttons to Change the value of the selected digit.

8.7.14.4 When desired value is displayed, press the Right (→) Arrow Button until the confirmation screen appears.

8.7.14.5 Press the Right (→) Arrow Button to Select the correct choice (Yes or No).

8.7.14.6 Press the Up (↑) Arrow to confirm the selected choice. This will lock in the new setting.

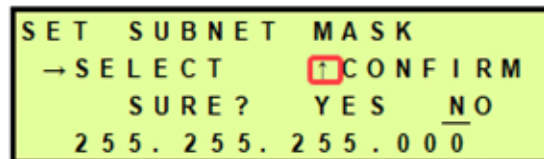

8.7.15 Set Gateway Address (default is 000.000.000.000) –

8.7.15.1 Press the Right (→) Arrow Button to access the edit screen.

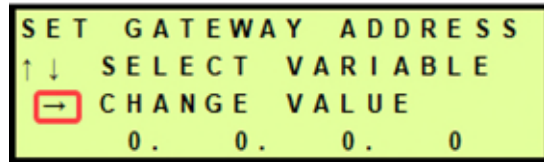

8.7.15.2 Press the Left (←) & Right (→) Arrow Buttons to Select the digit to change.

8.7.15.3 Press the Up (↑) & Down (↓) Arrow Buttons to Change the value of the selected digit.

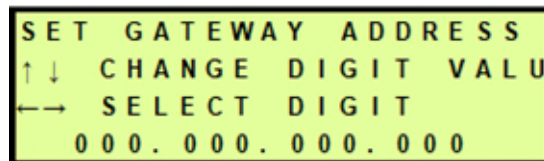

8.7.15.4 When desired value is displayed, press the Right (→) Arrow Button until the confirmation screen appears.

8.7.15.5 Press the Right (→) Arrow Button to Select the correct choice (Yes or No).

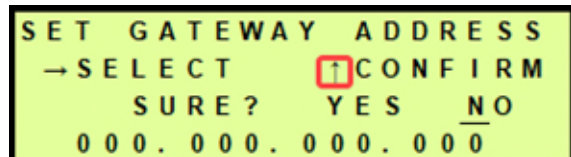

8.7.15.6 Press the Up (↑) Arrow to confirm the selected choice. This will lock in the new setting.

8.7.16 Set SNMP Trap Server (default is 000.000.000.000) –

8.7.16.1 Press the Right (→) Arrow Button to access the edit screen.

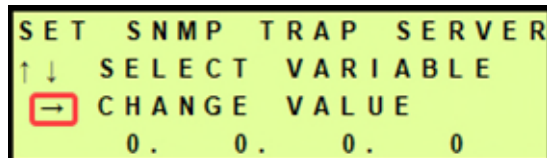

8.7.16.2 Press the Left (←) & Right (→) Arrow Buttons to Select the digit to change.

8.7.16.3 Press the Up (↑) & Down (↓) Arrow Buttons to Change the value of the selected digit.

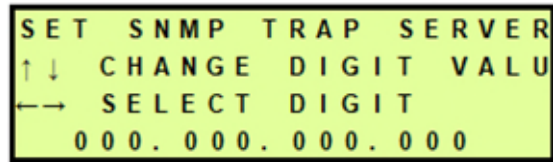

8.7.16.4 When desired value is displayed, press the Right (→) Arrow Button until the confirmation screen appears.

8.7.16.5 Press the Right (→) Arrow Button to Select the correct choice (Yes or No).

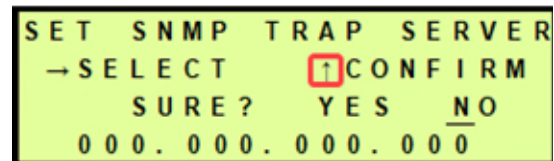

8.7.16.6 Press the Up (↑) Arrow to confirm the selected choice. This will lock in the new setting.

8.8 Open Panel

8.8.1 Open panel latches and remove the top panel.



8.9 Setting the System Pressure

With Compressor running:

- 8.9.1** Open Panel (see section 8.8).
- 8.9.2** Pull the Capacity Control Valve knob out.
- 8.9.3** Turn the knob until the reading on the Pressure Gauge is **50 PSI**.
- 8.9.4** Push the knob in to lock.
- 8.9.5** Close Panel.

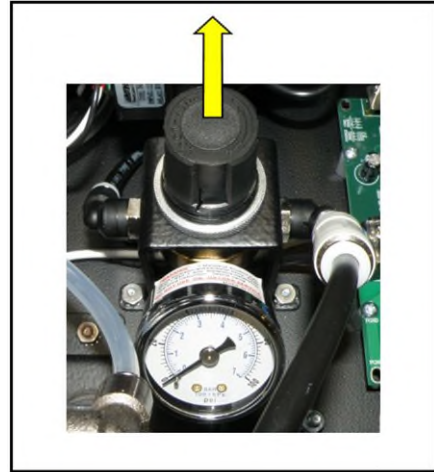

8.10 Setting the Outlet Pressure

8.10.1 Locate the outlet pressure regulator on the front of the unit

8.10.2 Turn knob until Outlet Pressure (**OUTP**) reading is at the desired setting.

8.10.3 Tighten the retaining nut to lock value in place.



8.11 Connecting to Common Alarm Terminals

8.11.1 Wire the Alarm Harness to monitoring device using the table below for reference:

	Wire #	Wire Color	Function
Power Fail Alarm	13	RED	SHORT on Alarm
	16	BLACK	
Common Alarm	14	BLACK	SHORT on Alarm
	17	BLUE	
Common Alarm	15	BLUE	OPEN on Alarm
	18	BLACK	

8.11.2 Connect the Alarm Harness to the Alarm Port on the back of the Dehydrator.



8.12 Connecting via Web Browser

If the Air Dryer IS connected to an IP network:

- The Air Dryer must be configured with a valid IP Address, Subnet Mask, and Gateway Address for the network.
- An IP cable is connecting the Air Dryer to the network.
- Use a computer that is on the same network as the air Dryer.
- Use Internet Explorer (6.0 or newer) or Mozilla Firefox Web Browser.

If the Air Dryer IS NOT connected to an IP network and has not been configured with IP information:

- Use the default IP Address (*192.168.1.102*) of the air dryer to connect.
- Use an IP Cable (may require Cross-over cable) plugged directly into a Laptop/PC and the other end plugged into the UTP Port on the control board of the Air Dryer.
- Configure the network card on the Laptop/PC to use the IP Address *192.168.1.101*. This will make the Laptop/PC compatible with the Air Dryer.
- Use Internet Explorer (6.0 or newer) or Mozilla Firefox Web Browser.

8.12.1 Type the IP Address of the P210WLP Series air Dryer in the Address text box of the web browser.

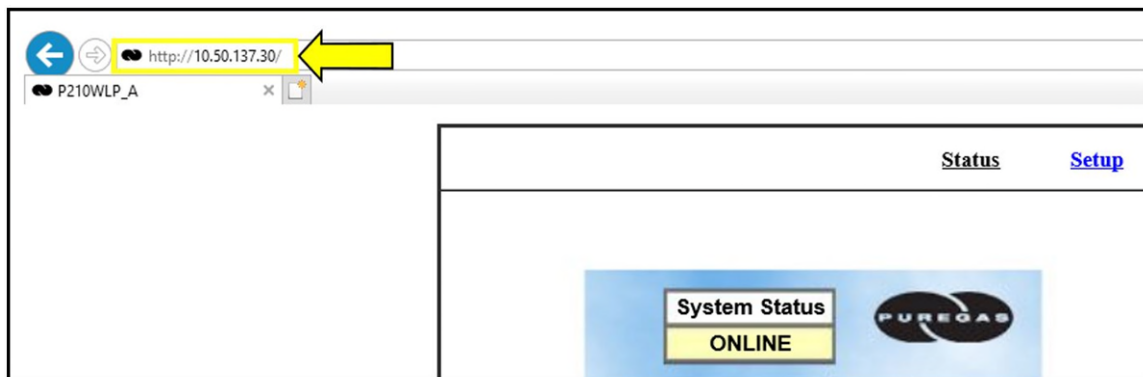

The Web Browser connection offers five (5) screens to the user:

- **Status Screen** - Displays the readings and alarms monitored in the P210WLP Series Air Dryer. Provides remote ALARM RESET.
- **Setup Screen** - All configurations of Set Points, Setups, and Keyword can be made in this screen.
- **Event/Alarm Screen** - Displays all events such as alarms, changes made, and alarm resets registered by the P210WLP Series Air Dryer. This screen is informational only.
- **Firmware Screen** – Allows the user to upload any software updates or upgrades to the Air Dryer.

8.12.2 Click on the Menu Bar selection to access a specific screen.

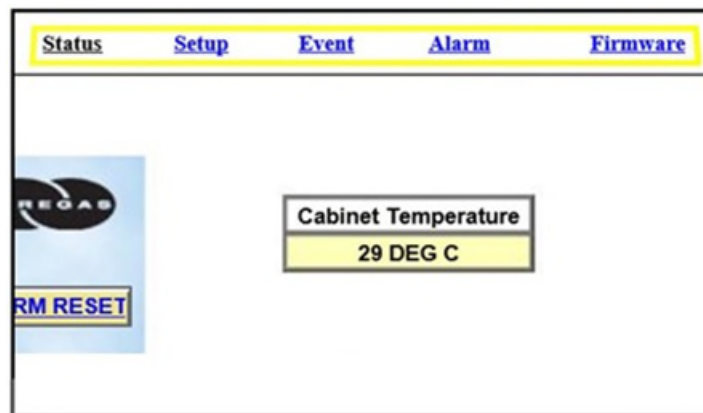

8.13 Using the Status Screen

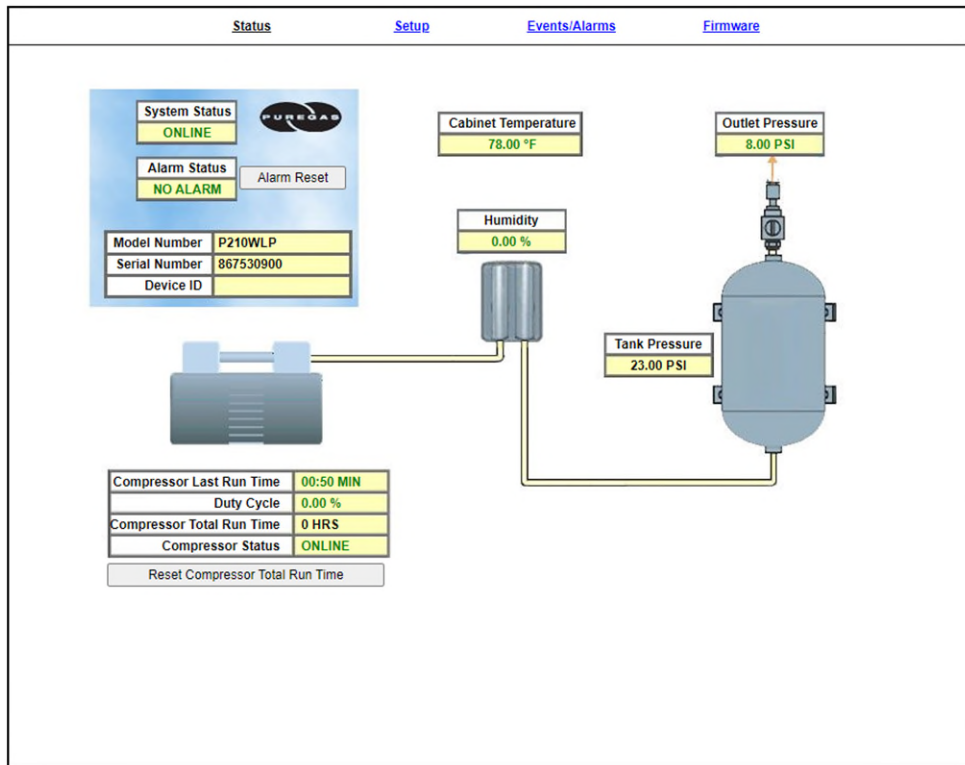

Displays the readings and alarms monitored in the P210WLP Series Air Dryer.
Provides remote ALARM RESET.

- Readings are displayed in **BLACK** unless an alarm is present.
- Alarms are displayed in **RED** next to the parameter in alarm.
- Alarm Status will display **Alarm** if any alarms are present.
- Keyword validation is required for ALARM RESET and RESET TOTAL RUN TIME.

8.13.1 Resetting an Alarm

8.13.1.1 Click on the **ALARM RESET** Button to remotely reset Air Dryer alarms displayed on Status Screen.

8.13.1.2 Enter Keyword (default is 123456)

8.13.1.3 Click on **SUBMIT** Button when done.

8.13.2 Resetting Compressor Total Run Time

8.13.2.1 Click on the **RESET TOTAL RUN TIME** Button to remotely reset Compressor Total Run Time displayed on Status Screen.

8.13.2.2 Enter Keyword (default is 123456)

8.13.2.3 Click on **SUBMIT** Button when done.

8.14 Using the Setup Screen

All configuration of Set Points, Setups, and Keyword can be made in this screen.

NOTE: Reference Appendix section 14.2 for Limits, Defaults, and Formats.

SYSTEM SETUP	
Description	Setting
ALARM DELAY	<input checked="" type="radio"/> ON <input type="radio"/> OFF
SNMP DISPLAY MODE	STRING <input type="button" value="v"/>
CURRENT DATE	10/11/19
CURRENT TIME	15:48
DEVICE ID	P210WLP_A

ALARM SETUP				
Description	Range	Default	Current	Unit
HIGH OUTLET PRESSURE	2.1 - 51.7	51.7	51.7	KPA
LOW OUTLET PRESSURE	2.1 - 51.6	2.1	2.1	KPA
HIGH HUMIDITY	3.0 - 15.0	10.0	3.0	%
HIGH DUTY CYCLE	0 - 99	70	70	%
COMPRESSOR LAST RUN TIME	02:00 - 10:00	05:00	10:00	MINS

NETWORK SETUP	
Description	Setting
IP ADDRESS	10.50.137.30
SUBNET MASK	255.255.255.0
GATEWAY ADDRESS	192.100.240.11
SNMP TRAP SERVER 1	0.0.0.0
SNMP TRAP SERVER 2	0.0.0.0
SNMP TRAP SERVER 3	0.0.0.0
SNMP TRAP SERVER 4	0.0.0.0

- Values in **BLUE** represent the current setting.
- The **ENTER** Button is used to change values.
- The **CHANGE KEYWORD** Button allows you to configure a new Keyword.
- Keyword validation is required to change values on the Setup Screen

8.14.1 Changing a threshold or Setup value:

8.14.1.1 Click on the value to change.

8.14.1.2 Type in the new value.

8.14.1.3 Click the **ENTER** Button when done.

8.14.1.4 Enter Keyword (default is 123456)

8.14.1.5 Click on **SUBMIT** Button when done. This will lock in the new setting value.

8.14.2 Changing the Keyword

8.14.2.1 Click on **CHANGE KEYWORD** Button to change the keyword.

8.14.2.2 Type the Old Keyword.

8.14.2.3 Type the New Keyword.

8.14.2.4 Type the Confirm New Keyword.

8.14.2.5 Click on **SUBMIT** Button to confirm. This will lock in the new setting value.

8.15 Using the Event Screen

Displays all events such as alarms, changes made, and alarm resets registered by the P210WLP Series Air Dryers. This screen is informational only.

Status Setup Event Alarm Firmware					
No.	Event	Description	Remark	Date ▼	Time ▼
1	Set Parameter	Use new humidity interface	SRC:IP	10/10/2019	14:19:36
2	Set Parameter	Use old humidity interface	SRC:IP	10/10/2019	14:19:26
3	Device Restart		User	10/10/2019	11:28:26
4	Set Parameter	Low Outlet Pressure Alarm Set Point	SRC:Web	10/09/2019	13:41:43
5	Device Restart		DownLoad	10/09/2019	13:30:12
6	Device Restart		DownLoad	10/09/2019	13:28:09
7	Device Restart		DownLoad	10/09/2019	07:41:09
8	Set Parameter	Alarm Delays Status - ON / OFF	SRC:Key	10/08/2019	16:16:57
9	Device Restart		PowerUp	10/08/2019	16:04:57
10	Device Restart		PowerUp	10/08/2019	16:04:12
11	Alarm Reset		SRC:Key	10/08/2019	16:03:54
12	Alarm Reset		SRC:Key	10/08/2019	16:03:47
13	Set Parameter	Excessive Compressor Run Time Alarm Set Point	SRC:Key	10/08/2019	16:00:48
14	Set Parameter	High Humidity Alarm Set Point	SRC:Key	10/08/2019	16:00:17
15	Set Parameter	Alarm Delays Status - ON / OFF	SRC:Key	10/08/2019	15:59:14
16	Device Restart		DownLoad	10/08/2019	08:33:25
17	Set Parameter	Alarm Delays Status - ON / OFF	SRC:Key	10/03/2019	16:33:07
18	Set Parameter	Alarm Delays Status - ON / OFF	SRC:Key	10/03/2019	16:33:01

 1 of 22

- Click on the column headings to sort data according to that column.
- Click the Arrow Buttons to navigate through all the event log pages.

8.16 Using the Firmware Screen

Displays the current firmware version and date of the P210WLP Series Air Dryers.

- **Current Version:** Displays the current firmware version of the P210WLP Air Dryer.
- **New Version File:** Displays the new location and new firmware version chosen.

Status	Setup	Event	Alarm	Firmware
Current Version: P210W2LP(P012300V20) Dryer, Version 1.03 09 Oct 19				
New Version File: <input type="text"/> Browse...				
ACCEPT				

- The **BROWSE** Button allows you to locate the new firmware file.
- The **ACCEPT** Button is used to change values.
- Keyword validation is required to update firmware.

8.16.1 Updating the Firmware:

8.16.1.1 Click on **BROWSE** Button to locate the firmware file.

8.16.1.2 Navigate and Select the correct .bin file. Press the **OK** Button.

8.16.1.3 Click the **ACCEPT** Button when done

8.16.1.4 Enter Keyword (default is 123456)

8.16.1.5 Click on **SUBMIT** Button when done. This will lock in the new firmware version.

8.17 Connecting via SNMP

Using SNMP to connect and communicate with the P210WLP Series Air Dryer is dependent upon the specific SNMP Management software used on your network. This software requires a SNMP Definition & Configuration File (MIB file) in order to properly communicate with the Air Dryer.

The files for the P210WLP Series Air Dryers can be downloaded from our website (AltecAIR.com) under the Product Support section SNMP Files link. It is necessary to import this file into your SNMP operating software.

NOTE: Reference Appendix section 14.3 for a list of SNMP Parameters including Limits, Defaults, and Formats.

9. Testing Your Dryer

9.1 Safety & Warning Information



WARNING!

Extreme care should be exercised to avoid contact with live electrical circuits. Many procedures performed during installation, operation, testing, and maintenance of this Air Dryer require the equipment to be running, creating a situation for potential electrical shock. It is highly recommended that you remove all jewelry before performing any procedures.



WARNING!

Internal surfaces may be hot. Use care when coming into contact with internal components as there is a potential for some of these components to become hot when in operation or standby.



WARNING!

High Noise. ALTEC AIR air-dryers are meant to be installed in an unattended area.



CAUTION!

Observe precautions for handling **Electrostatic Sensitive Devices.**



CAUTION!

Depressurizing the air Dryer may be necessary before performing certain procedures. **NEVER** remove pressure sensing tubes from the control board without depressurizing the Air Dryer first, or **damage to the control board will occur.**

9.2 Measuring Compressor Amp Draw



WARNING!

Internal surfaces may be hot. Use care when coming into contact with internal components as there is a potential for some these components to become hot when in operation or standby.

With the Compressor running:

9.2.1 Open Panel (see section 8.8).

9.2.2 Locate wire #19 coming directly from the compressor

9.2.3 Use an Amp Meter to measure the running amps.

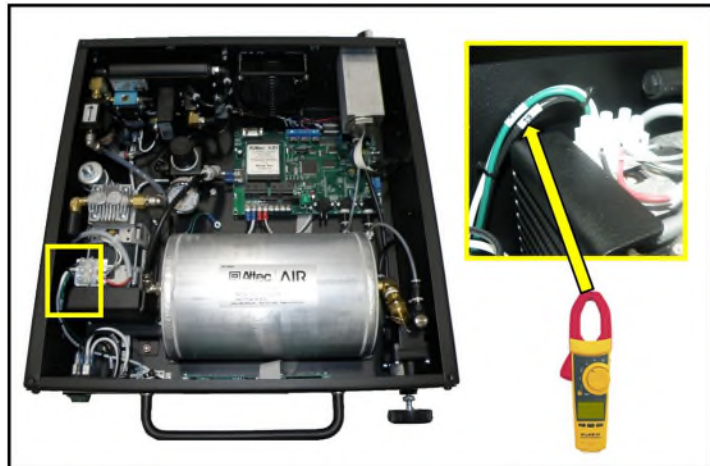

With the compressor running, the running amps should measure **1.0 amp or below.**

9.2.4 Close Panel.

If the compressor measures over 1.0 running amps, see section 13.16 for troubleshooting information.

9.3 Measuring Compressor Voltage



WARNING!

Extreme care should be exercised to avoid contact with live electrical circuits. It is highly recommended that you remove all jewelry before performing any procedures.

9.3.1 Open Panel (see section 8.8).



9.3.2 Locate the relay terminal block “TB1” on the control board inside the air Dryer.

9.3.3 Slide off clear plastic terminal block cover.

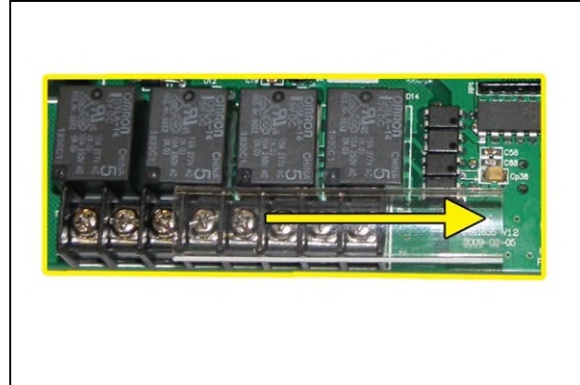

With the Compressor running:

9.3.4 Use a Voltmeter to measure across the board terminals where wires #6 and #7 are connected. The voltage should measure **115 VAC (±10%)** for P210WLP models and **230 VAC (±10%)** for P212WLP models.

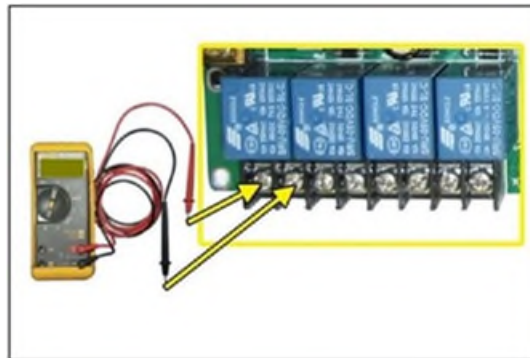

With the Compressor NOT running:

9.3.5 Use a Voltmeter to measure across the board terminals where wires #6 and #7 are connected. The voltage should measure **0 VAC (±10%)**.

9.3.6 Close Panel.

If any of the voltage measurements are different than indicated above, the Control Board is defective and should be replaced. See sections 11.1 for part detail and 11.5 for ordering information.

9.4 Measuring Incoming Voltage

**WARNING!**

Extreme care should be exercised to avoid contact with live electrical circuits. It is highly recommended that you remove all jewelry before performing any procedures.

9.4.1 Open Panel (see section 8.8).

9.4.2 Locate the incoming power terminal block on the control board marked “AC IN”

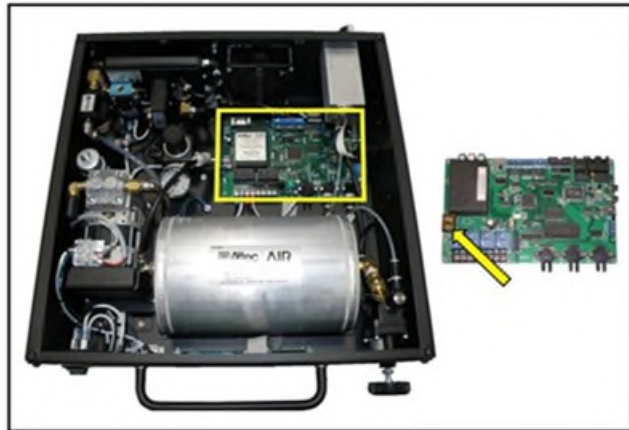

- 9.4.3** Use a Voltmeter to measure across the board terminals where wires #4 and #5 are connected.

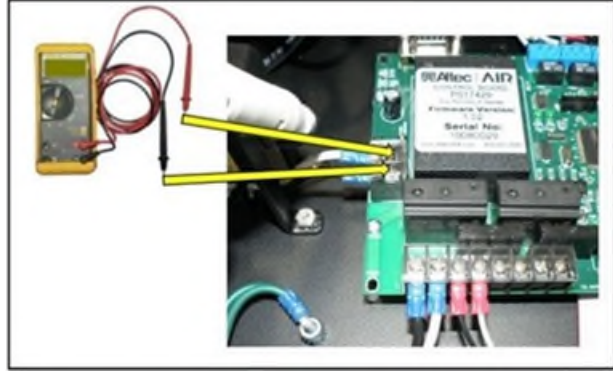

The voltage should measure **110 - 125 VAC** for the P210WLP or **208 - 253 VAC** for the P212WLP.

- 9.4.4** Close Panel.

If the incoming voltage measures less than indicated above, it is recommended that steps be taken at your facility to increase the power to the recommended level of voltage.

9.5 Testing Consistent Heatless Dryer Cycling



WARNING!

Internal surfaces may be hot. Use care when coming into contact with internal components as there is a potential for some of these components to become hot when in operation or standby.

With the Compressor running:

- 9.5.1** Locate the purge port on the rear of the unit



- Place your hand behind the purge port to feel for purging air. Air should be steadily purging from the port, and a burst of air should be felt every 60 seconds as the dryer cycles between towers.

If the Heatless Dryer is not cycling consistently as described, see section 13.13 for troubleshooting information.

9.6 Measuring Heatless Dryer Solenoid Voltage

With the Compressor running:

9.6.1 Locate the Heatless Dryer Cycle Timer.

The timer has two (2) sets of terminals (from top-to-bottom):

“**VALVE**” – controls solenoid
 “**IN**” – Incoming power



9.6.2 Use a Voltmeter to measure the AC voltage across the set of “**VALVE**” terminals. The voltage reading should alternate between **110 - 125 VAC** for the P210WLP or **208 - 253 VAC** for the P212WLP and zero voltage approximately every 60 seconds as the timer cycles.

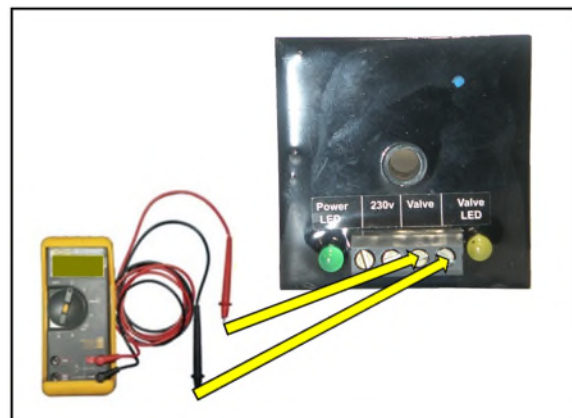

If the voltage does not measure approximately the same as the incoming system voltage the Cycle Timer could be defective. See sections 11.3 for troubleshooting information.

9.7 Testing Air Dryer Fan

NOTE: To test the fan, the cabinet temperature must be above 90° F (32° C).

9.7.1 Locate the fan exhaust on the rear of the unit.

9.7.2 Place your hand outside the Dryer to feel for air being blown outwards.



NOTE: Fan will turn OFF when the cabinet temperature is below 80° F (27° C).

If the fan is not blowing air outwards as described:

- *Verify the cabinet temperature is above 90° F (32° C).*
- *Check for loose wiring. Refer to the Wiring Diagram (section 0)*
- *Replace defective fan (see sections 11.1 for part detail and 11.5 for ordering information).*
- *Replace defective control board if fan does not respond properly to temperature changes (see sections 11.1 for part detail and 11.5 for ordering information).*

9.8 Testing Compressor ON/OFF Cycling

9.8.1 When the Unit Screen (8.5.5.1) displays TANK press the **HOLD Button** on the Front Panel to freeze that screen.



With Compressor running:

9.8.2 Verify the compressor shuts down when the tank pressure (**TANK**) reaches **50 PSI (344.7 KPA)**.

*If the tank pressure (**TANK**) fails to reach 50 PSI (344.7 KPA), see section 13.15 for troubleshooting information.*

With Compressor NOT running:

⚠ CAUTION: Be careful when removing Air hose. System is pressurized.

9.8.3 Depressurize air Dryer (see section 8.3.3)

9.8.4 Verify the compressor turns on when the tank pressure (**TANK**) falls to **20 PSI (137.9 KPA)**.

9.8.5 Reconnect air hose.

If the Compressor Cycling fails either test described, it indicates a problem with the Control Board which will need to be replaced. See sections 11.1 for part detail and 11.5 for ordering information.

9.9 Testing High Compressor Last Run Time Alarm

⚠ CAUTION: Be careful when removing Air hose. System is pressurized.

NOTE: For this test, allow the Display Screen to cycle through the information screens.

9.9.1 Start timing when the compressor turns on.

9.9.2 Depressurize air Dryer (*See sections 11.1 for detail*).

This prevents the compressor from shutting down.

When the compressor runs for 5:00 minutes (unless adjusted to a different Set Point by the user), a High Compressor Last Run Time (**LAST RUN**) alarm should appear on the System Screen.

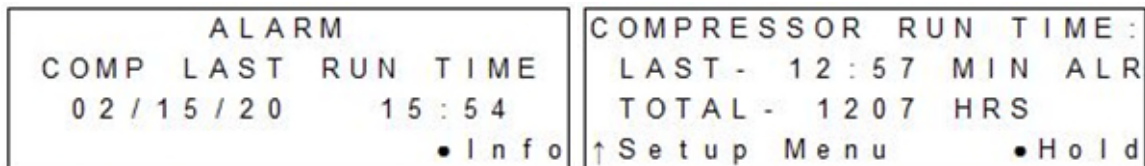

9.9.3 Press the **RESET Button** to clear the alarm.

If you are unable to create a High Compressor Last Run Time alarm as described, see section 13.18 for troubleshooting information.



9.10 Testing Humidity Alarm and System Shutdown

⚠ CAUTION: Be careful when removing Air hose. System is pressurized.

9.10.1 Power the air Dryer
OFF.

9.10.2 Depressurize air Dryer
(see section 8.3.3)



9.10.3 Disconnect the humidity sensor
from the control board lead

9.10.4 Unscrew and remove the Humidity
Sensor from the Humidity Block.

9.10.5 With the sensor removed from the
humidity block, re-connect the humidity sensor to the control board lead



9.10.6 Power the air Dryer **ON**.

Allow the Humidity reading to rise over 10.0%.

9.10.7 After one (1) minute, verify that a Humidity Alarm appears, and the Dryer goes into **SHUTDOWN** mode.

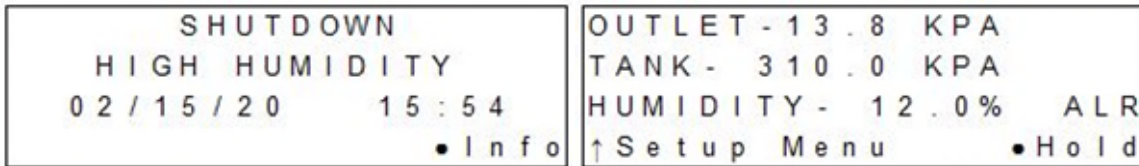

9.10.8 Replace the Humidity Sensor into the Humidity Block.

9.10.9 Press the **RESET Button** to clear the Humidity alarm.

If you are unable to create a Humidity / Shutdown alarm as described, see section 13.10 for troubleshooting information.



9.11 Testing High Outlet Pressure Alarm

9.11.1 Make a note of the current Outlet Pressure (**OUTP**) reading.

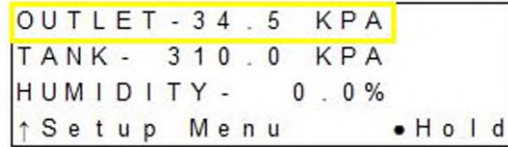

9.11.2 Loosen the retaining nut on the outlet pressure regulator.

9.11.3 Turn knob clockwise until Outlet Pressure (**OUTP**) reading climbs over the high outlet pressure threshold (7.5 PSI, 51.7 KPA default). After one (1) minute, the High Pressure Alarm should appear on the display.

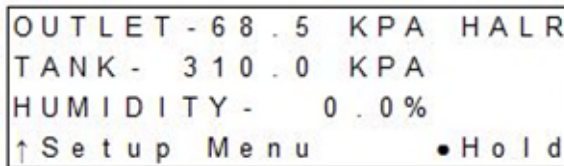
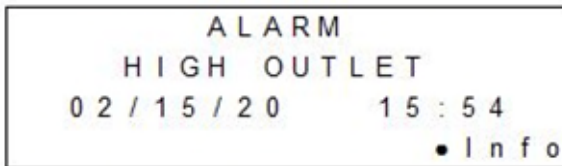

9.11.4 Turn Outlet Pressure Regulator knob counter-clockwise until Outlet Pressure (**OUTP**) reading lowers to the reading recorded in step 9.11.1

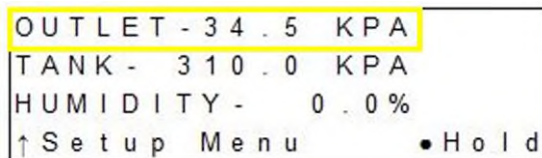

9.11.5 Tighten the retaining nut to lock the setting in place



9.11.6 Press the **RESET Button** to clear the alarm.

If you are unable to create a High Outlet Pressure Alarm as described, see section 13.6 for troubleshooting information.



9.12 Testing Low Outlet Pressure Alarm

9.12.1 Make a note of the current Outlet Pressure (**OUTP**) reading.

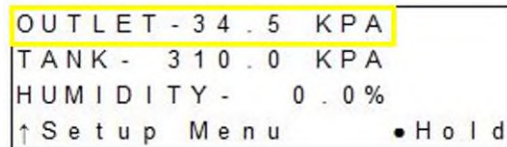

9.12.2 Loosen the retaining nut on the Outlet Pressure Regulator.

9.12.3 Turn knob counter-clockwise until Outlet Pressure (**OUTP**) reading drops below the low outlet pressure threshold (0.3 PSI, 2.1 KPA default). After one (1) minute, the Low Pressure Alarm should appear on the display.

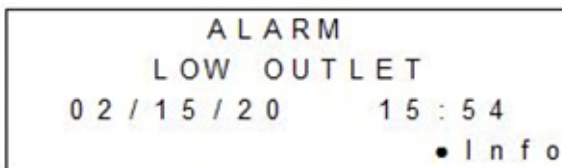
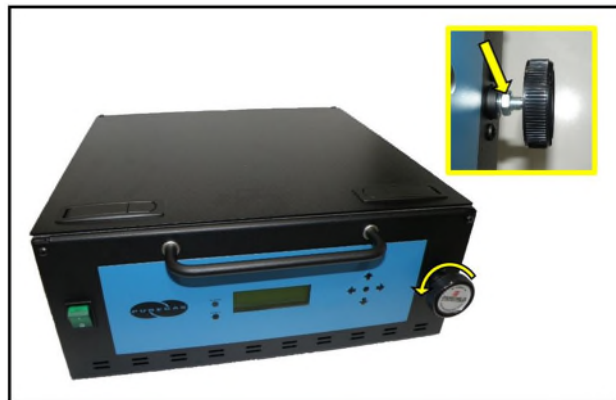

9.12.4 Turn Outlet Pressure

Regulator knob clockwise
until Outlet Pressure (**OUTP**)
reading rises to the reading
recorded in step 9.12.1

```

OUTLET - 34.5 KPA
TANK - 310.0 KPA
HUMIDITY - 0.0%
↑ Setup Menu      • Hold
  
```

9.12.5 Tighten the retaining nut to lock the setting in place.**9.12.6 Press the RESET Button.**

If you are unable to create a Low Outlet Pressure Alarm as described, see section 13.8 for troubleshooting information.

**9.13 Testing Air Fittings & Hoses for Leaks**

NOTE: This is a general procedure that can be applied to any fitting or hose that has air pressure in it. **DO NOT SOAP TEST THE HUMIDITY SENSOR FITTING. DAMAGE TO THE SENSOR MAY OCCUR.**

With Compressor NOT running:

9.13.1 Listen for any 'hissing' sounds which may indicate a fitting or hose air leak.

With Compressor running:

9.13.2 Use a 1-inch paint brush to dab soapy water on the air fitting or hose connection to be tested.

If air bubbles appear at the connection, this indicates that air is leaking from the connection.

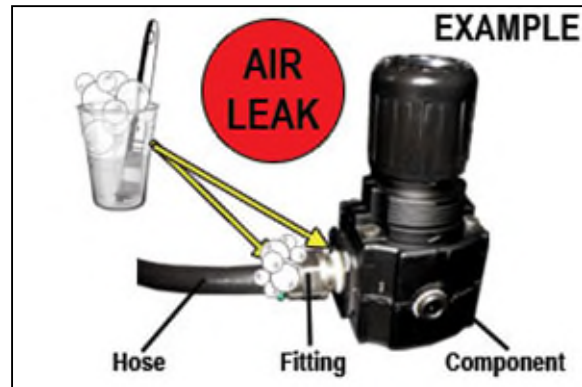

If any leaks are detected, take steps to seal them off (as necessary):

- *Tighten the fitting*
- *Re-connect the hose end*
- *Replace the fitting / hose / component*

10. Maintaining Your Dryer

In order to ensure that your P210WLP Series Air Dryer continues to operate efficiently and reliably, Altec AIR recommends performing preventative maintenance procedures at the specified six month and annual intervals.

In the event of a high duty cycle application, it may be necessary to perform preventative maintenance at more frequent intervals, which will be indicated by a compressor total hour alarm. Refer to *Compressor Total Hour Alarm (section 10.3)*. Ensure that this alarm is reset after each annual maintenance interval to prevent accidental duplicate maintenance. Refer to *Reset Compressor Total Hours (section 10.3)*.

It is also recommended that you print out the included *Six Month Maintenance (section 10.2)* and *Annual Maintenance (section 10.3)* log sheets and record all completed maintenance for historical tracking and reference purposes.

The log sheets include a Section reference column which indicates the User's Guide section containing the information about the specific procedure. Please refer to these sections for detailed procedural information.

NOTE: When operating at higher ambient temperatures, it is recommended that maintenance be performed more frequently.

10.1 Safety & Warning Information



WARNING!

Extreme care should be exercised to avoid contact with live electrical circuits. Many procedures performed during installation, operation, testing, and maintenance of this Air Dryer require the equipment to be running, creating a situation for potential electrical shock. It is highly recommended that you remove all jewelry before performing any procedures.



WARNING!

Internal surfaces may be hot. Use care when coming into contact with internal components as there is a potential for some of these components to become hot when in operation or standby.



CAUTION!

SHUT DOWN IMMEDIATELY FOR REPAIRS if the air compressor shows any evidence of overheating or presents excessive noise.



CAUTION!

Depressurizing the air Dryer may be necessary before performing certain procedures. **NEVER** remove pressure sensing tubes from the Control Board without depressurizing the Air Dryer first, or **damage to the Control Board will occur.**



WARNING!

High Noise. Altec AIR air-dryers are meant to be installed in an unattended area.



CAUTION!

Observe precautions for handling **Electrostatic Sensitive Devices**.



IMPORTANT!

Performing routine maintenance as outlined in the *Maintaining Your Dryer* section will ensure optimal performance over the lifecycle of your Air Dryer.



IMPORTANT!

Performing procedures not described in this User's Guide or installing components not supplied by Altec AIR is **NOT RECOMMENDED AND MAY VOID THE WARRANTY**.



IMPORTANT!

After performing any maintenance, always soap test pressure fittings to check for air leaks. Also, check for any loose or disconnected wiring.

10.2 Six Month Maintenance

MODEL: _____

LOCATION NAME: _____

SERIAL NUMBER: _____

ADDRESS: _____

DATE INSTALLED: _____

Procedure	Section	Maintenance Interval (Months)				
		6	12	18	24	30
Measure & Record Compressor Amp Draw	9.2					

Measure & Record Incoming Voltage (must be 110 - 125 VAC for P210WLP models and must be 208 - 253 VAC for P212WLP models)	9.4					
Test High & Low Outlet Pressure Alarms	9.11 & 9.12	<input type="checkbox"/>	<input type="checkbox"/>	<input type="checkbox"/>	<input type="checkbox"/>	<input type="checkbox"/>
Set System Pressure (50 PSI)	8.8	<input type="checkbox"/>	<input type="checkbox"/>	<input type="checkbox"/>	<input type="checkbox"/>	<input type="checkbox"/>
Set Outlet Pressure	8.10	<input type="checkbox"/>	<input type="checkbox"/>	<input type="checkbox"/>	<input type="checkbox"/>	<input type="checkbox"/>
Test Consistent Heatless Dryer Cycling	9.5	<input type="checkbox"/>	<input type="checkbox"/>	<input type="checkbox"/>	<input type="checkbox"/>	<input type="checkbox"/>
Test Fan	9.7	<input type="checkbox"/>	<input type="checkbox"/>	<input type="checkbox"/>	<input type="checkbox"/>	<input type="checkbox"/>
Test Compressor ON/OFF Cycling	9.8	<input type="checkbox"/>	<input type="checkbox"/>	<input type="checkbox"/>	<input type="checkbox"/>	<input type="checkbox"/>
Test High Compressor Last Run Time Alarm	9.9	<input type="checkbox"/>	<input type="checkbox"/>	<input type="checkbox"/>	<input type="checkbox"/>	<input type="checkbox"/>
Test Humidity Alarm & System Shutdown	9.10	<input type="checkbox"/>	<input type="checkbox"/>	<input type="checkbox"/>	<input type="checkbox"/>	<input type="checkbox"/>
Test Air Fittings for Leaks	9.13	<input type="checkbox"/>	<input type="checkbox"/>	<input type="checkbox"/>	<input type="checkbox"/>	<input type="checkbox"/>
Visually Inspect Inside & Outside of Unit for Loose Wiring or Hardware		<input type="checkbox"/>	<input type="checkbox"/>	<input type="checkbox"/>	<input type="checkbox"/>	<input type="checkbox"/>
Maintenance Performed by:						
Date of Maintenance:						

NOTE: COPY OR PRINT THIS PAGE AND KEEP IT WITH THE AIR DRYER

10.3 Annual Maintenance

MODEL: _____ LOCATION NAME: _____
 SERIAL NUMBER: _____ ADDRESS: _____
 DATE INSTALLED: _____

Note: In the event of a high duty cycle application, it may be necessary to perform preventative maintenance at more frequent intervals, which will be indicated by a compressor total hour alarm. Refer to *Compressor Total Hour Alarm (section 8.6.6)*

Procedure	Section	Maintenance Interval				
		1 Year	2 Year	3 Year	4 Year	5 Year

Install Annual Maintenance Kit	11.4	<input type="checkbox"/>	<input type="checkbox"/>	<input type="checkbox"/>	<input type="checkbox"/>	<input type="checkbox"/>
Measure & Record Compressor Amp Draw	9.2					
Set System Pressure (50 PSI)	8.8	<input type="checkbox"/>	<input type="checkbox"/>	<input type="checkbox"/>	<input type="checkbox"/>	<input type="checkbox"/>
Set Outlet Pressure	8.10	<input type="checkbox"/>	<input type="checkbox"/>	<input type="checkbox"/>	<input type="checkbox"/>	<input type="checkbox"/>
Test Consistent Heatless Dryer Cycling	9.5	<input type="checkbox"/>	<input type="checkbox"/>	<input type="checkbox"/>	<input type="checkbox"/>	<input type="checkbox"/>
Test Compressor ON/OFF Cycling	9.8	<input type="checkbox"/>	<input type="checkbox"/>	<input type="checkbox"/>	<input type="checkbox"/>	<input type="checkbox"/>
Test Air Fittings for Leaks	9.13	<input type="checkbox"/>	<input type="checkbox"/>	<input type="checkbox"/>	<input type="checkbox"/>	<input type="checkbox"/>
Reset TTL TIME Reading to Zero	9.13	<input type="checkbox"/>	<input type="checkbox"/>	<input type="checkbox"/>	<input type="checkbox"/>	<input type="checkbox"/>
Visually Inspect Inside & Outside of Unit for Loose Wiring or Hardware		<input type="checkbox"/>	<input type="checkbox"/>	<input type="checkbox"/>	<input type="checkbox"/>	<input type="checkbox"/>
Maintenance Performed by:						
Date of Maintenance:						

Note: After annual maintenance is performed ensure that the compressor total hour count is reset. Refer to *Reset Compressor Total Hours (section 8.7.4)*

NOTE: COPY OR PRINT THIS PAGE AND KEEP IT WITH THE AIR DRYER

11. Replacement Parts & Accessories

11.1 Dryer Parts

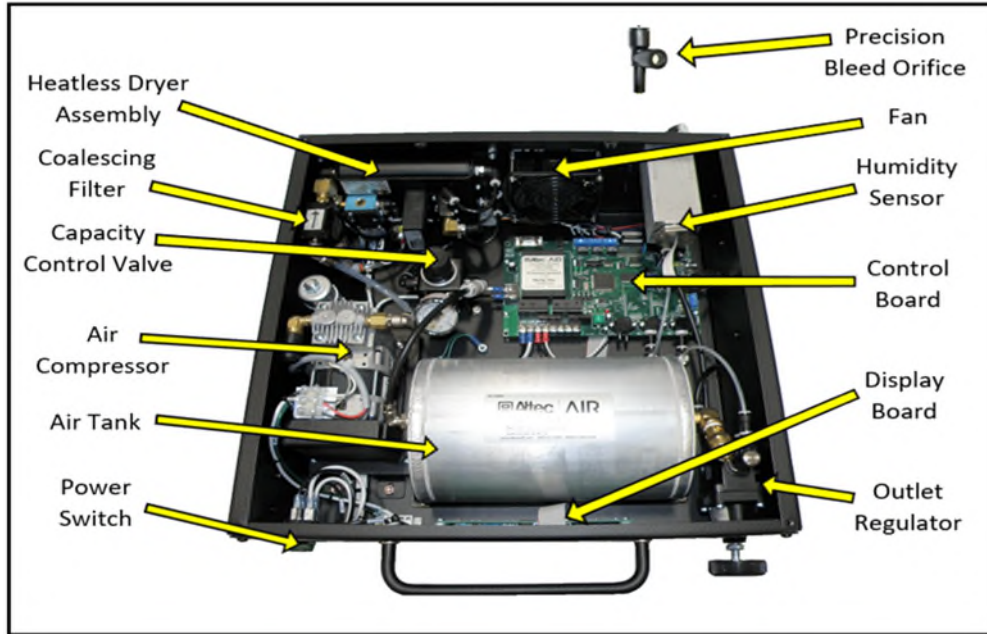

Description	Part Number	Quantity	Recommend Spare
Precision Bleed Orifice	P013349	1	
Heatless Dryer Assembly	<i>See section 11.3 for detail</i>		✓ (1)
Coalescing Filter	100519630	1	
Fan	P013720	1	
Capacity Control Valve	P017421	1	✓ (1)
Humidity Sensor – (Section 11.2 (Type 1) (Type 2) (Type 3)	P011380 P013403 P013401	1	
Air Compressor - 115V Units 230V Units	P017420 P017441	1	✓ (1)
Control Boards – (Section 11.2) Standard Pressure (Type A) Standard Pressure (Type B) Low Pressure (Type A)	P017439 P013708 P017429	1	✓ (1)
Air Tank	P017411	1	
Display Board	P011694	1	
Power Switch	M038428	1	
Outlet Pressure Regulator	P017410	1	

11.2 Dryer Parts Cont. (Circuit Board Selection)

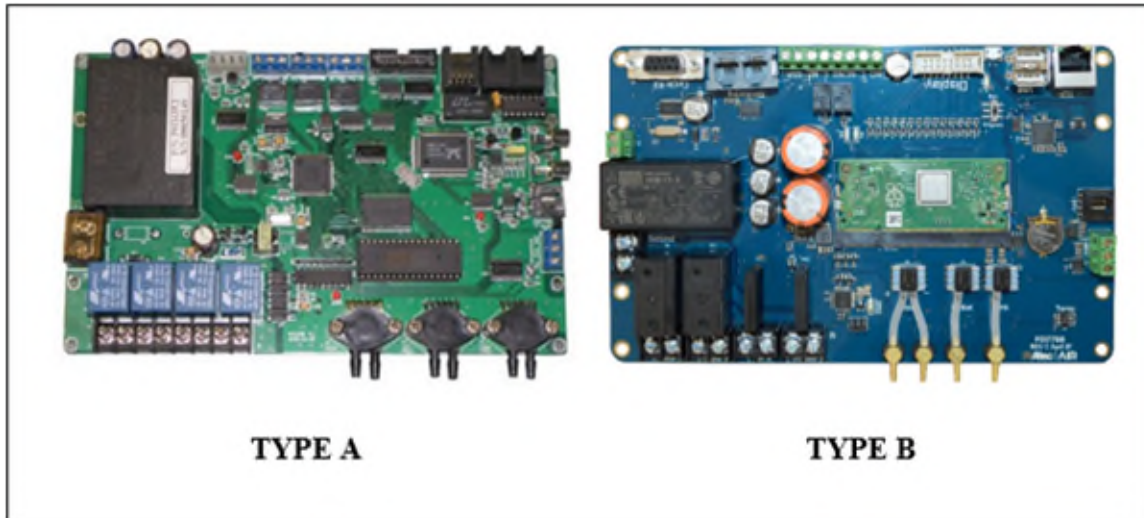

Circuit Board Comparison to determine correct Replacement Part #



TYPE 1



TYPE 2



**TYPE 3
(Blue Label)**

- *Type 3 sensor can **ONLY** be used with Type B circuit board
- *Type 1 and 2 sensors can **ONLY** be used with Type A circuit board
- *Sensors **MUST** be replaced with identical sensor; however, Type 1 and 2 are interchangeable. (E.g., Type 1 and 2 replaced with either type 1 or 2. Type 3 replaced with type 3.)

11.3 Heatless Dryer Assembly Parts

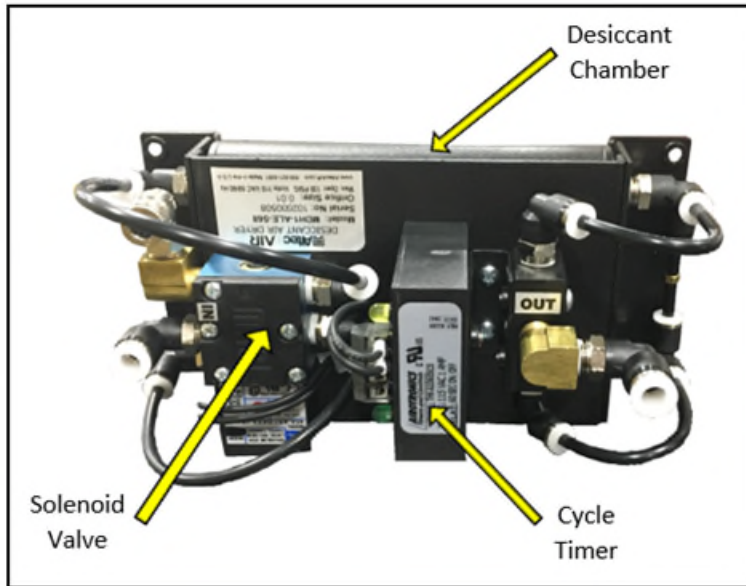

Description	Part Number	Quantity
Heatless Dryer -		
115V Units	MDH1-ALE-S68	1
230V Units	MDH1-DLE-S68	1
Desiccant Chamber	51843	2
Cycle Timer		
115V Units	51800	1
230V Units	50022	1
Solenoid Valve		
115V Units	10043	1
230V Units	10043-220V	1

11.4 Accessories for Your Dryer

Description	Part Number	Recommend Spare
Annual Maintenance Kit Includes replacement filter element and compressor maintenance kit.	P017612	✓ (1)
Horizontal Wall Mounting Kit Includes mounting brackets and hardware.	P017460	
Server Rack Mounting Ear Kit (Pair)	P017703	
Cycle Kit Allows multiple dryers to be cycled.	P08033W	
Cycle Kit Interface Kit	PVDW34	
Rack Latch Kit	100520428	

11.5 Ordering Parts from Altec AIR



IMPORTANT!

Instruction for the replacement of individual listed components goes beyond the scope of this User's Guide and will not be covered. Please refer to the information included with the specific replacement part for this instruction.

Once you have identified your required parts and accessories, contact the Altec AIR Inside Sales / Parts Orders department to order:

(800) 521-5351 (option 2)

Fax – (303) 657-2205

sales@AltecAIR.com

12. Service & Repair

Only Altec AIR can offer factory direct rebuilds backed by a 6 month factory warranty.

- 2 week turnaround time
- Estimates available upon request
- Minimum service charge fee applies

12.1 Services Offered

- **Piston Compressor Rebuild**
 - Replace motor bearings, piston rod assemblies, and install a complete compressor maintenance kit.
 - Test air flow, air pressure, and electrical performance
- **Heatless Dryer Rebuild**
 - Replace desiccant, o-rings, timer, springs, and complete solenoid assembly
 - Test proper component operation
- **Desiccant Tower Repack**
 - Clean out tower and replace desiccant, filter, and o-ring
- **Circuit Board Repair** (Limited to current model boards only)
- **Complete Dryer Repair**

12.2 Initiating a Service Transaction

- Contact our Service Department at **1-800-521-5351 (option 3)** to obtain a Return Authorization (RA) number.
- Carefully package the item(s) to be returned.
 - Reference *section 10.3* for steps to take prior to boxing dryer
- Mark the Return Authorization (RA) number on the outside of the shipping container.
- Include the main address and phone number of the individual to contact for related inquiry and follow-up information.
- Include the purchase order number.

13. Troubleshooting Your Dryer

13.1 Before You Call Altec AIR

PLEASE READ THIS SECTION FIRST. It is important that you use the following sections in order to diagnose and attempt to fix the problem with your Air Dryer before placing a call to Altec AIR Technical Support.

This troubleshooting guide is intended to simplify the isolation of problems, present possible causes, provide test procedures for verification, and suggest corrective actions to restore the air Dryer back to normal operation. Each section begins with the most likely cause(s) of the issue. Otherwise, they start from the simplest possibilities and progress to more complicated ones.

This troubleshooting guide is designed to be easy to follow and very effective when used properly. It is suggested to always start at the beginning of the specific problem section and continue in sequence, following the procedures indicated.

13.2 Safety & Warning Information



WARNING!

For your safety, all the information in this User's Guide must be followed to minimize the risk of electrical shock, and prevent property damage or personal injury.



WARNING!

Internal surfaces may be hot. Use care when coming into contact with internal components as there is a potential for some of these components to become hot when in operation or standby.

**WARNING!**

Extreme care should be exercised to avoid contact with live electrical circuits. Many procedures performed during installation, operation, testing, and maintenance of this air Dryer require the equipment to be running, creating a situation for potential electrical shock. It is highly recommended that you remove all jewelry before performing any procedures.

**CAUTION!**

Depressurizing the air Dryer may be necessary before performing certain procedures. **NEVER** remove pressure sensing tubes from the Control Board without depressurizing the air Dryer first, or **damage to the Control Board will occur.**

**CAUTION!**

Do not test the Humidity Sensor with an ohm meter or apply any DC voltage. This will render the Humidity Sensor defective.

**WARNING!**

High Noise. Puregas air-dryers are meant to be installed in an unattended area.

**CAUTION!**

Observe precautions for handling **Electrostatic Sensitive Devices.**

**IMPORTANT!**

Performing procedures not described in this User's Guide or installing components not supplied by Altec AIR is **NOT RECOMMENDED AND MAY VOID THE WARRANTY.**

13.3 Air Dryer Won't Power ON

Possible Cause	Check	Corrective Action
POWER Switch in OFF position	Verify POWER switch is in the ON position (section 8.4)	Turn POWER switch to the ON position (section 8.4)
No incoming voltage to air Dryer	Measure incoming voltage (section 9.4)	Troubleshoot facility power supply to air Dryer

13.4 Display Screen Not Functioning

Possible Cause	Check	Corrective Action
Dryer experienced a power surge		Power the air Dryer OFF for 15+ seconds. Power the air Dryer ON .
Ribbon cable disconnected	Verify ribbon cable from the decal is connected at the display board	Reconnect the ribbon cable properly.

13.5 High Outlet Pressure Alarm

Possible Cause	Check	Corrective Action
Outlet Pressure set too high	Verify Outlet Pressure (OUTP) reading (section 8.5.5.1)	Adjust outlet pressure regulator (section 8.10)
High Outlet Pressure Alarm set point too low	Verify High Outlet Pressure Alarm set point (section 8.5.5.1)	Raise High Outlet Pressure Alarm set point (section 8.5.5.1)

13.6 Can't Create a High Pressure Alarm

Possible Cause	Check	Corrective Action
Defective Outlet Pressure Regulator	Verify that the Outlet Pressure Regulator can be adjusted (section 8.10)	Replace Outlet Pressure Regulator if unable to adjust pressure (section 11.1)
High Outlet Pressure Alarm set point higher than default setting	Verify High Outlet Pressure Alarm set point (section 8.7)	Adjust Outlet Pressure Regulator so that Outlet Pressure (OUTP) reading climbs over

		verified set point (section 9.11)
Defective Control Board	Verify that the Outlet Pressure (OUTP) reading is higher than the High Outlet Pressure Alarm set point (Section 8.7)	Replace Control Board (section 11.1) if Outlet Pressure (OUTP) reading is over verified High Outlet Pressure Alarm set point for more than 1 minute and fails to create an alarm.

13.7 Low Outlet Pressure Alarm

Possible Cause	Check	Corrective Action
Outlet Pressure set too low	Verify Outlet Pressure (OUTP) reading (section 8.5.5.1)	Adjust outlet pressure regulator (section 8.10)
Low Outlet Pressure Alarm set point too high	Verify Low Outlet Pressure Alarm set point (section 8.7)	Lower the Low Outlet Pressure Alarm set point (section 8.7)
Leak in the air system	With no outlet flow, test fittings and hoses for leaks (section 9.13)	Tighten any loose connections as required

13.8 Can't Create a Low Pressure Alarm

Possible Cause	Check	Corrective Action
Defective Outlet Pressure Regulator	Verify that the Outlet Pressure Regulator can be adjusted (section 8.10)	Replace Outlet Pressure Regulator if unable to adjust pressure (section 11.1)
Low Outlet Pressure Alarm set point lower than default setting	Verify Low Outlet Pressure Alarm set point (section 8.7)	Adjust Outlet Pressure Regulator so that Outlet Pressure (OUTP) reading drops below verified set point (section 9.12)
Defective Control Board	Verify that the Outlet Pressure (OUTP) reading is lower than the Low Outlet Pressure Alarm set point (above)	Replace Control Board (section 11.1) if Outlet Pressure (OUTP) reading is under verified Low Outlet Pressure Alarm set point for more than 1 minute and fails to create an alarm.

13.9 High Humidity



CAUTION!

Do not test the Humidity Sensor with an ohm meter or apply any DC voltage. This will render the Humidity Sensor defective.

Possible Cause	Check	Corrective Action
Low System Pressure	Verify System Pressure (section 8.9)	Adjust System Pressure to 50 PSI, \pm 2 PSI. (section 8.9)
Low Flow Rate	Verify Duty Cycle reading is greater than 10% (section 8.6.7)	Install the included Precision Bleed Orifice fitting to maintain a constant air flow. (section 8.2)
High Humidity Alarm set point too low	Verify High Humidity Alarm set point (section 8.7) If Flow Rate is low, allowing a higher alarm set point (up to 10%) will allow Dryer to run within acceptable levels.	Raise High Humidity Alarm set point (section 8.7) Over 10% not recommended
Defective Humidity Sensor	Perform the Testing Humidity Alarm and System Shutdown test (section 9.10)	Troubleshoot <i>Can't Create a High Humidity Alarm / Shutdown</i> condition (section 13.10)
Heatless Dryer not cycling between towers	Verify consistent Heatless Dryer cycling (section 9.5)	Troubleshoot <i>Inconsistent Heatless Dryer Cycling</i> condition (section 13.13)
Defective Control Board	Unplug Humidity Sensor from Control Board (see section 11.1 for Board location) Humidity reading should drop to 0%	If Humidity did not immediately change to **. *% replace Control Board (section 11.1)

13.10 Can't Create a High Humidity Alarm / Shutdown

These troubleshooting steps assume that the Humidity Element is removed from the Humidity Block during the *Testing Humidity Alarm and System Shutdown* (section 9.10) procedures.

Possible Cause	Check	Corrective Action
Defective Humidity Sensor	Verify that Humidity reading fails to climb higher than 15% or creates sporadic readings	Replace Humidity Sensor (section 11.1)
Defective Control Board	Verify that Humidity reading is over 15% for more than 1 minute	Replace Control Board if no alarm is created and system does not shut down (section 11.1)

13.11 High Duty Cycle Alarm

Possible Cause	Check	Corrective Action
High System Pressure	Verify System Pressure (section 8.9)	Adjust System Pressure to 50 PSI, \pm 2 PSI. (section 8.9)
High Downstream Flow condition	Verify outlet flow from dryer is within unit specifications	Reduce dryer outlet flow requirement or set duty cycle alarm threshold accordingly
Leak in air system	Check all hoses and fittings between compressor and Air Tank for air leaks (section 9.13)	Connect, tighten, or replace leaking component
Defective control board	Measure voltages at control board (section 9.3)	If measurements are incorrect, replace control board (section 11.1)

13.12 High Cabinet Temperature Alarm

Possible Cause	Check	Corrective Action
Fan Failure	Verify fan is running (section 9.7)	Check for loose fan wiring (section 0) Replace defective fan (section 11.1)

High Ambient Temperature	Verify temperature of Dryer operating location. Recommended ambient temperature is 40°-85°F.	Lower the ambient temperature of the Dryer's operating location
--------------------------	--	---

13.13 Inconsistent Heatless Dryer Cycling

Possible Cause	Check	Corrective Action
Defective Solenoid Valve	Measure voltage going to the Heatless Dryer Solenoid Valve (section 9.6)	If 110 - 125 VAC for the P210WLP or 208 - 253 VAC for the P212WLP IS present, replace Solenoid valve
Defective Cycle Timer	Measure voltage going to the Heatless Dryer Solenoid Valves (section 9.6)	If 110 - 125 VAC for the P210WLP or 208 - 253 VAC for the P212WLP IS NOT present, replace cycle timer (section 11.3)

13.14 Compressor Doesn't Operate

Possible Cause	Check	Corrective Action
Defective compressor	Measure compressor voltage (section 9.3)	If voltage is good, replace compressor (section 11.1) or send it in for repair (section 12.)
Defective control board	Measure compressor voltage (section 9.3)	If measurements are incorrect, replace control board (section 11.1)
System is in Shutdown state	On the Display Panel, verify that the system is in SHUTDOWN state	Press the RESET Button
Compressor stalled	Measure compressor voltage (section 9.3) & Verify System Pressure (section 8.9)	Adjust incoming voltage / system pressure if necessary and Power the air Dryer OFF for 15+ seconds. Power the air Dryer ON .

13.15 Compressor Won't Build Pressure

Possible Cause	Check	Corrective Action
Low System Pressure	Verify System Pressure (section 8.9)	Adjust System Pressure to 50 PSI, \pm 2 PSI. (section 8.9)
Leak in air system	Check all hoses and fittings between compressor and Air Tank for air leaks (section 9.13)	Connect, tighten, or replace leaking component
Compressor Piston Leaking	Check the pressure of the outlet air coming from the compressor to the pressure setting on the capacity control valve	Replace the compressor piston seal included in the Annual maintenance kit

13.16 Compressor Excessive AMP Draw

Possible Cause	Check	Corrective Action
Restriction in air line	Remove Discharge Hose from compressor (hose to the heatless Dryer) Re-measure Compressor AMP Draw (section 9.2)	If measurement is below the recommended amps, trace hoses from compressor to Capacity Control Valve looking for restrictions or kinks
Compressor failing	Remove Discharge Hose from compressor (hose to the heatless Dryer) Re-measure Compressor AMP Draw (section 9.2)	If measurement is still above the recommended amps, replace the compressor (section 11.1) or send it in for repair (section 12.)

13.17 High Compressor Last Run Time Alarm

Possible Cause	Check	Corrective Action
Low System Pressure	Verify System Pressure (section 8.9)	Adjust System Pressure to 50 PSI, \pm 2 PSI. (section 8.9)
Leak in air system	Check all hoses and fittings between compressor and Air Tank for air leaks (section 9.13)	Connect, tighten, or replace leaking component
High Downstream Flow condition	Verify outlet flow from dryer is within unit specifications	Reduce dryer outlet flow requirement or set Compressor Last Run Time alarm threshold accordingly
Defective control board	Check that the compressor cuts out when the tank reading reaches 50 PSI (344.7 KPA) (section 9.3)	Replace Control Board (section 11.1)

13.18 Can't Create a High Compressor Last Run Time Alarm

Possible Cause	Check	Corrective Action
High Compressor Last Run Time Alarm set point higher than the default of 3:00 minutes	Verify High Compressor Last Run Time Alarm set point (section replace Control Board (section 11.1))	Allow the compressor to run longer than the verified set point (section 9.9)
Defective Control Board	Verify that the compressor has run longer than the verified High Compressor Last Run Time Alarm set point (above)	Replace Control Board (section 11.1) if the compressor runs longer than the verified High Compressor Last Run Time Alarm set point by 1 minute or more and fails to create an alarm.

13.19 Compressor Rapid ON/OFF Cycling

Possible Cause	Check	Corrective Action
Defective control board	Measure voltages at control board (section 9.3)	If measurements are incorrect, replace control board (section 11.1)

13.20 Contacting Altec AIR Technical Support

Please read the *Before You Call Altec AIR* section (13.1)

Once you have exhausted all of the potential problems and solutions covered in the *Troubleshooting Your Dryer* section, and you still require further assistance to correct a problem, contact Altec AIR Technical Support:

(800) 521-5351 (**option 1**)

Have the following information available:

Trouble Ticket # (if following-up on a previous call): _____

Technician Name: _____ **Phone #:** _____

Model #: _____ **Serial #:** _____

Company Name: _____ **Location Name:** _____

City: _____ **State:** _____

14. Appendix

14.1 Wiring Diagram

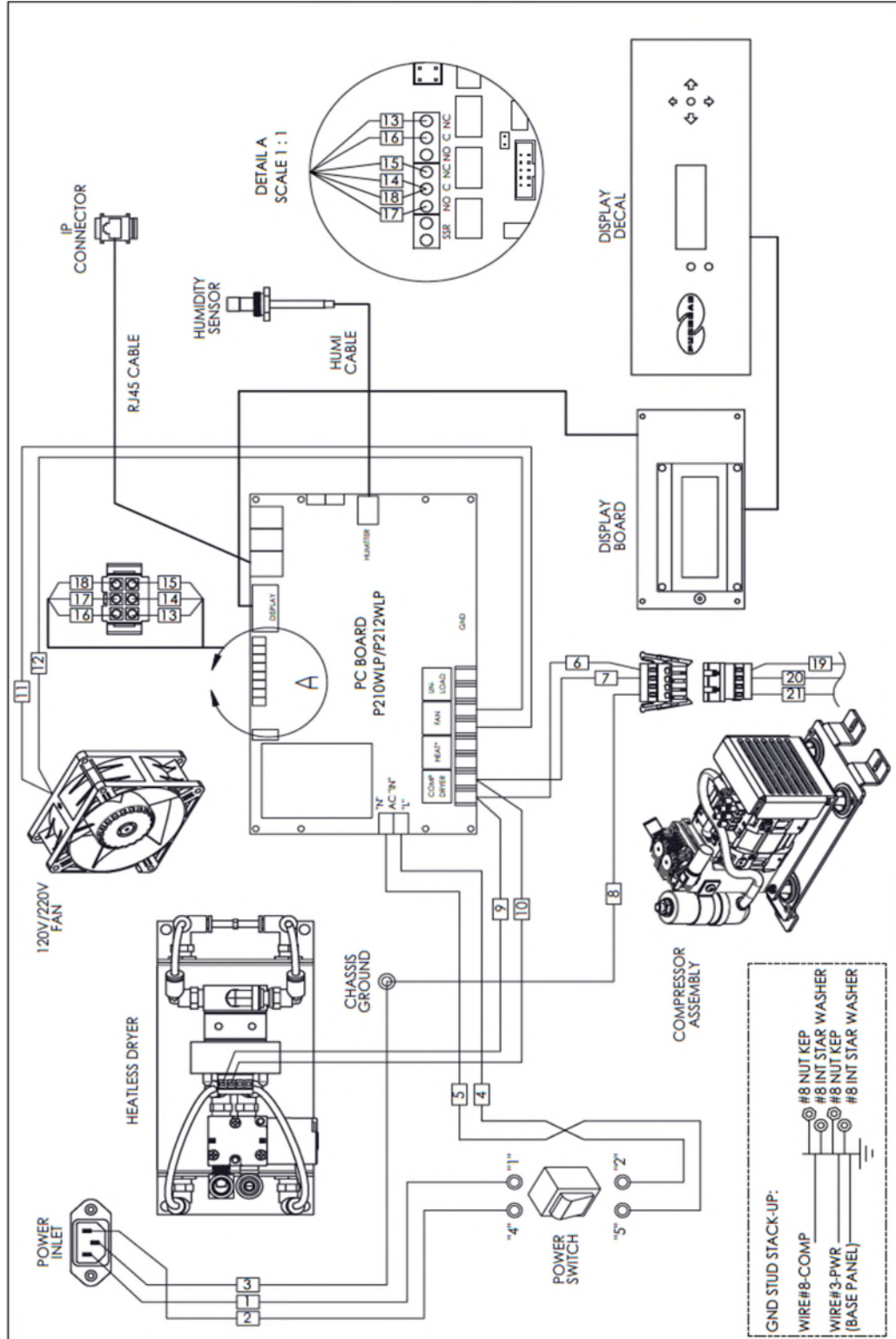

14.2 Set Point Limits and Defaults

14.2.1 System Adjustments

Description	Minimum Value	Maximum Value	Default Value	Unit of Measurement
System Pressure			50	PSI
Outlet Pressure	0.30 (2.1)	7.5 (51.7)		PSI (KPA)
Alarm Delay	OFF	ON	ON	

14.2.2 Alarm Set Points

Description	Minimum Value	Maximum Value	Default Value	Unit of Measurement	Shutdown
High Outlet Pressure Alarm	0.30 (2.1)	7.50 (51.7)	7.50 (51.7)	PSI (KPA)	
Low Outlet Pressure Alarm (LP UNITS)	0.30 (2.1)	7.50 (51.7)	0.30 (2.1)	PSI (KPA)	
High Humidity Alarm	3	15	10	%	YES
High Duty Cycle Alarm	0	99	70	%	
High Compressor Last Run Time Alarm	2:00	10:00	5:00	Minutes	
High Cabinet Temperature Alarm			120 (49)	DEG F (DEG C)	YES
Compressor Total Run Time Alarm			2,000	Hours	

14.2.3 System Operations

Description	ON Value	OFF Value	Default Value	Unit of Measurement
Compressor	20 (137.9)	50 (344.7)		PSI (KPA)
Fan	90 (32.2)	80 (26.7)		DEG F (DEG C)

14.3 SNMP Parameters

Device Configuration Information

Device ID	Alphanumeric (Defined by Customer)
Device Model	Alphanumeric (Factory Preset)
Device Firmware Version	Numeric (Factory Preset)
Current Date/Time	Numeric (mm/dd/yy hh:mm)
IP Address	Numeric (xxx.xxx.xxx.xxx)
Subnet Mask	Numeric (xxx.xxx.xxx.xxx)
Gateway Address	Numeric (xxx.xxx.xxx.xxx)
SNMP Trap Server Address	Numeric (xxx.xxx.xxx.xxx)
SNMP Read Community String (also sets SNMP Trap Community String)	Alphanumeric (6-14 digits, Default = "public")
SNMP Write Community	Alphanumeric (6-14 digits, Default = "123456")

Status Readings (Read-Only)

Outlet Pressure Reading	Numeric (PSI or KPA)
Tank Pressure Reading	Numeric (PSI or KPA)
Humidity Reading	Numeric (%)
Cabinet Temperature Reading	Numeric (DEG F or C)
Duty Cycle Reading	Numeric (%)
Compressor Total Run Time Reading	Numeric (Hours)
Compressor Last Run Time Reading	Numeric (Seconds)
System Status	ON / SHUTDOWN
Compressor Status	ON / OFF
Fan Status	ON / OFF

Alarm Readings (Read-Only)

High Humidity Alarm	OK / Alarm
High Outlet Pressure Alarm	OK / Alarm
Low Outlet Pressure Alarm	OK / Alarm
High Cabinet Temperature Alarm	OK / Alarm
Duty Cycle Alarm	OK / Alarm
High Compressor Last Run Time Alarm	OK / Alarm
Maintenance Required Alarm	OK / Alarm
Total Alarm	OK / Alarm

Configuration Settings (Read-Write)

High Humidity Alarm Threshold	Numeric (%)
High Outlet Pressure Alarm Threshold	Numeric (PSI or KPA)
Low Outlet Pressure Alarm Threshold	Numeric (PSI or KPA)
Duty Cycle Alarm Threshold	Numeric (%)
High Compressor Last Run Time Alarm Threshold	Numeric (Seconds)
Reset Compressor Total Run Time Reading	Numeric (Hours)
Start Up Delay	Numeric (Seconds)
Alarm Reset	RESET
Alarm Delay	ON / OFF

Alarm Traps Sent to SNMP Server

High Humidity
High Outlet Pressure
Low Outlet Pressure
High Cabinet Temperature
High Duty Cycle
High Compressor Last Run Time
Maintenance Required

15. Limited Warranty Agreement

Altec AIR products carry a one (1) year warranty against defective workmanship and material. This period starts at date of shipment. Not included are the components subject to normal replacement during a year's operating time.

No claims for labor in replacing defective parts or for consequential damages will be allowed. Replacement parts will be invoiced in the regular way, with invoices subject to adjustment after the parts claimed defective are examined at our factory. In addition, no material or parts will be accepted at our factory for in-warranty repairs or credit without previous authorization from Altec AIR.

Responsibility for damages incurred in transit will be borne by the user and the user in turn should file any damage claim against the carrier. All warranty items are F.O.B. Broomfield, Colorado. Freight charges are the responsibility of the user.

This warranty shall not apply to any Altec AIR product which shall have been repaired or altered in any way by anyone other than Altec AIR or authorized personnel so as to affect, in our judgment, its proper functioning or reliability, neither will it apply to any product which has been subject to misuse, negligence, or accident. The installation of unauthorized non Altec AIR parts will void the warranty on those Altec AIR products.

Registration Reminder

If you haven't already done so, please take a moment to register your PUREGAS P210WLP Series Air Dryer. **Registering is necessary to activate this Limited Warranty on your product.** Once you register, you are eligible to receive free technical support, as well as updates concerning your Altec AIR products.

See Section 7. for details on Registering Your Dryer.

16. Contacting Altec AIR

16.1 General

Altec AIR, LLC
226A Commerce Street
Broomfield, Colorado 80020

(800) 521-5351

(303) 427-3700

Fax – (303) 657-2233

info@AltecAIR.com

www.AltecAIR.com

16.2 Sales

(800) 521-5351 (**option 2**)

Fax – (303) 657-2205

sales@AltecAIR.com

parts@AltecAIR.com

16.3 Service

(800) 521-5351 (**option 3**)

Fax – (303) 657-2205

16.4 Technical Support

(800) 521-5351 (**option 1**)

DON'T FORGET TO REGISTER YOUR DRYER!

See Section 7. for details on Registering Your Dryer.

