

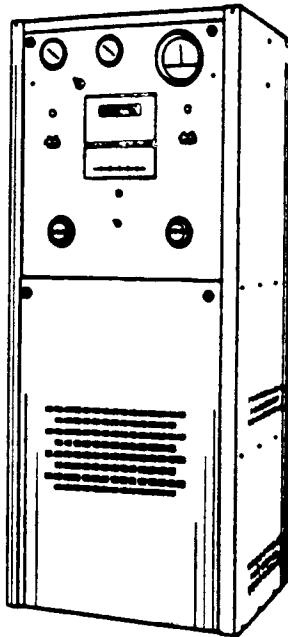

**PUREGAS INSTRUCTION MANUAL  
MODEL P-06500D  
CENTRAL OFFICE  
AIR DRYER**



**MOBILE TOOL  
INTERNATIONAL, INC.**

AMERQUIP - MOPECO - PUREGAS - TELSTA  
MIT INSULATED PRODUCTS

EMPLOYEE OWNED

· 5600	West 88th Ave., Westminster, Colorado 80030	1-800-521-5351 FAX (303) 657-2545 or (303) 427-3700
· 1434	Hughes Ford Road, Frederick, Maryland 21701	(301) 662-6262 or FAX (301) 694-9644
· 4588	Carter Court, Chino, California 91710	(909) 613-1766 or FAX (909) 613-1770
· 1104	Everee Inn Road, Griffin, Georgia 30223	(770) 227-9423 or FAX (770) 227-9100
· 2121	Research Drive, Fort Wayne, Indiana 46808	(219) 482-4401 or FAX (219) 482-4075
· 9733	Indianapolis Road, Fort Wayne, Indiana 46809	(219) 747-1631 or FAX (219) 747-6732
· 118	Little Valley Court, Birmingham, Alabama 35244	(205) 987-7534 or FAX (205) 987-7557
· R.D. 1, Box 582,	Honeybrook, Pennsylvania 19344	(610) 942-2500 or FAX (610) 942-9195

P-08506

\$10.50

MADE IN USA · MARCH 1993

## **PREFACE**

*This instruction manual is produced for the benefit of our customers. It is intended to provide basic information which will enable our customers to install, maintain and service PUREGAS air dryers economically, capably and with minimum delay. Careful observation of these instructions and maintenance procedures will ensure maximum life and efficiency of the unit.*

*This manual should be read thoroughly before installing, operating or servicing the air dryer to familiarize the technician with the unit and the proper operating and repair procedures. This will minimize the possibility of damage to the unit due to improper operation, handling or disassembly.*

**Please direct all inquiries to:  
PUREGAS  
5600 West 88th Avenue  
WESTMINSTER, COLORADO 80030  
1-800-521-5351 or (303) 427-3700**

**NO PART OF THIS TECHNICAL MANUAL  
MAY BE REPRODUCED WITHOUT THE EXPRESS WRITTEN  
CONSENT OF MOBILE TOOL INTERNATIONAL.**

### **LIMITED WARRANTY AGREEMENT**

*Puregas air dryers carry a two-year warranty against defective workmanship and material. This period starts at date of shipment. Not included are components subject to normal replacement during a years operating time. These parts include, but are not limited to, electrical components, pressure switches, pressure regulators and piston-type air compressors which carry a one year warranty.*

*On refrigeration type dryers, the basic refrigeration circuit carries a five-year warranty. This warranty covers the refrigeration compressor, refrigeration tubing and coils but NOT the thermostat, thermometer, or fan motor.*

*Liquid-ring compressors, heatless dryers and circuit boards carry a two-year warranty.*

*No claims for labor in replacing defective parts or for consequential damages will be allowed. Replacement parts will be invoiced in the regular way with invoices subject to adjustment after the parts claimed defective are examined at our factory. In addition, no material or parts will be accepted at our factory for in-warranty repairs or credit without previous authorization from Puregas, Mobile Tool International.*

*Responsibility for damages incurred in-transit will be borne by the user and the user, in turn should file any damage claim against the carrier. All warranty items are F.O.B. our plant. Freight charges are the responsibility of the user.*

*This warranty shall not apply to any air dryer which shall have been repaired or altered in any way by anyone other than Puregas, Mobile Tool International so as to affect, in our judgement, its proper functioning or reliability, neither will it apply to a dryer which has been subjected to misuse, negligence or accident.*

**THE INSTALLING OF PARTS PURCHASED  
FROM OTHER THAN PUREGAS/MOBILE TOOL INTERNATIONAL  
WILL VOID THE WARRANTY ON OUR AIR DRYERS.**

# Table of Contents

## SECTION 1

### GENERAL

Scope of Manual . . . . .	Page	-1-
Initial Inspection . . . . .	Page	-1-
Warranty . . . . .	Page	-1-

## SECTION 2

### DESCRIPTION

## SECTION 3

### PRINCIPLES OF OPERATION

Air System . . . . .	Page	-4-
Air Compressor . . . . .	Page	-4-
Heatless Dryer . . . . .	Page	-4-
Humidity Sensing Tube . . . . .	Page	-7-
Capacity Control Valve . . . . .	Page	-7-
Pressure Switch and Storage Tank . . . . .	Page	-7-
Flow Tube Control Regulator, Meter and Alarm . . . . .	Page	-7-
Humidity Bypass Solenoid Valve . . . . .	Page	-8-
Pressure Regulator and Shut-Off Valve . . . . .	Page	-8-
High/Low Pressure Switch . . . . .	Page	-8-
Air Dryer - Auto/Manual Mode . . . . .	Page	-8-
Alarm Summary . . . . .	Page	-10-
Alarm Summary (continued) . . . . .	Page	-11-
High Flow Alarm . . . . .	Page	-11-
Humidistat . . . . .	Page	-11-
Dessicant . . . . .	Page	-11-
Logic Scan LED . . . . .	Page	-11-
Alarm LED . . . . .	Page	-11-

## SECTION 4

### INSTALLATION AND START-UP

Inspection . . . . .	Page	-12-
Accessories . . . . .	Page	-12-
Installation Procedure . . . . .	Page	-12-
Location . . . . .	Page	-13-
Electrical Hook-up . . . . .	Page	-13-
Start Up . . . . .	Page	-14-

## SECTION 5

### TEST PROCEDURES

Low Pressure Alarm Test . . . . .	Page	-16-
High Pressure Alarm Test . . . . .	Page	-16-

Humidity Condition Test . . . . .	Page -16-
Humidity Alarm Test . . . . .	Page -18-
Compressor Performance Test . . . . .	Page -20-

**SECTION 6  
MAINTENANCE**

Routine Maintenance . . . . .	Page -22-
Six Month Check . . . . .	Page -22-
One Year (or 4,000 hours) . . . . .	Page -22-
2 Years (or 8,000 hours) . . . . .	Page -23-
Maintenance Matrix . . . . .	Page -23-
Air Compressor Safety Valves . . . . .	Page -24-
Air Compressor Pressure Switch . . . . .	Page -24-
High/Low Pressure Alarm Adjustment . . . . .	Page -25-
Capacity Control Valve Adjustment . . . . .	Page -26-
Air Compressor Maintenance Kit . . . . .	Page -26-
Optional Equipment . . . . .	Page -26-
Air Compressor Troubleshooting Chart . . . . .	Page -27-
Air Compressor Disassembly . . . . .	Page -28-
Air Compressor Assembly . . . . .	Page -28-
Heatless Dryer . . . . .	Page -29-
Pressure Regulator . . . . .	Page -29-
Bypass Solenoid Valve . . . . .	Page -29-
Humidity Alarm . . . . .	Page -30-

**SECTION 7  
TROUBLESHOOTING GUIDE**

Alarm Display Summaries . . . . .	Page -41-
Problem A: Hi Pres. appears at the alarm display. . . . .	Page -41-
Problem B: Low Pres. appears at the alarm display. . . . .	Page -41-
Problem C: C.P. Sys. appears at the alarm display. . . . .	Page -41-
Problem D: -HC- appears at the alarm display. . . . .	Page -41-
Problem E: Humi.-1 or Humi.-2 appears at the alarm display. . . . .	Page -41-
Air System	
Problem A: Low Pressure Alarm . . . . .	Page -42-
Problem B: High Pressure Alarm . . . . .	Page -43-
Problem C: Compressor performance alarm cannot be reset. . . . .	Page -44-
Problem D: Compressor will not build pressure. . . . .	Page -44-
Humidity Alarm System	
Problem A: Air Dryer in Humidity Alarm . . . . .	Page -45-
Problem B: Air Dryer Humidity Alarm doesn't function . . . . .	Page -46-
Electrical System	
Problem A: No power to the air dryer . . . . .	Page -47-
Problem B: No power to the air compressor. . . . .	Page -47-

Problem C: Power to dryer, but the air compressor does not operate. . . Page -47-  
Dehydrator . . . . . Page -48-  
Problem A: Heatless dryer delivers wet air . . . . . Page -48-  
Problem B: A white powder is in the cable or exhaust . . . . . Page -49-  
Problem C: Heatless dryer has excessive drop in outlet pressure. . . . . Page -49-

# P-06500D CENTRAL OFFICE AIR DRYER FIGURES AND CHARTS

FIGURE	TITLE	PAGE
1	Outline Dimensions . . . . .	2
2	Air Flow Diagram . . . . .	5
3	Theory of Heatless Drying . . . . .	6
4	Electrical Hook-up . . . . .	13
5	Logic Board . . . . .	15
6	Latching Alarm D.I.P. Switch . . . . .	15
7	Humidity Time Delay Switch . . . . .	17
8	SSR Board . . . . .	19
9	Compressor Performance Time Delay Switch . . . . .	21
10	Air Compressor Pressure Switch . . . . .	24
11	High/Low Pressure Switch . . . . .	25
12	Exploded View Dehydrator (S/S Timer Model) . . . . .	33
13	Exploded View/Air Compressor & Motor Assy. . . . .	34
14	Front Control Panel . . . . .	35
15	Reverse Side of Control Panel . . . . .	36
16	Air Compressor Compartment . . . . .	37
17	Heatless Dryer - Top Control Panel . . . . .	38
18	Wiring Diagram . . . . .	39
CHART	TITLE	PAGE
1	Air Dryer Characteristics . . . . .	3
2	Maintenance Matrix . . . . .	23
3	Air Compressor Troubleshooting Chart . . . . .	27
4	Dehydrator Parts List (S/S Timer Model) . . . . .	32

# DESCRIPTION, OPERATION AND MAINTENANCE

## PUREGAS MODEL P-06500D

### CENTRAL OFFICE AIR DRYER

#### SECTION 1

#### GENERAL

##### 1.1 Scope of Manual

This instruction manual covers the description, operating principles, installation and start up, test procedures, maintenance and troubleshooting techniques for the Model P-06500D air dryer. This dryer supplies a normal continuous delivery of up to 7600 SCFD of dry air at adjustable pressures of 0-15 PSIG for continuous feed pressure cables, pipe systems or other devices requiring dry air. The Model P-06500D is designed for indoor use.

##### 1.2 Initial Inspection

Carefully inspect both the exterior and interior of the air dryer for any shipping damage.

##### **IMPORTANT!**

**Any shipping damage must be brought to the immediate attention of the carrier. Manufacturer is not responsible for shipping damage.**

##### 1.3 Warranty

Before starting dryer, read manual thoroughly to become acquainted with the principles of operation. Follow installation, start-up and test procedures in proper sequence so as not to void the warranty.

**CAUTION:**  
**FAILURE TO FOLLOW PROPER SEQUENCE FOR INSTALLATION,  
START-UP AND TEST WILL VOID THE WARRANTY**



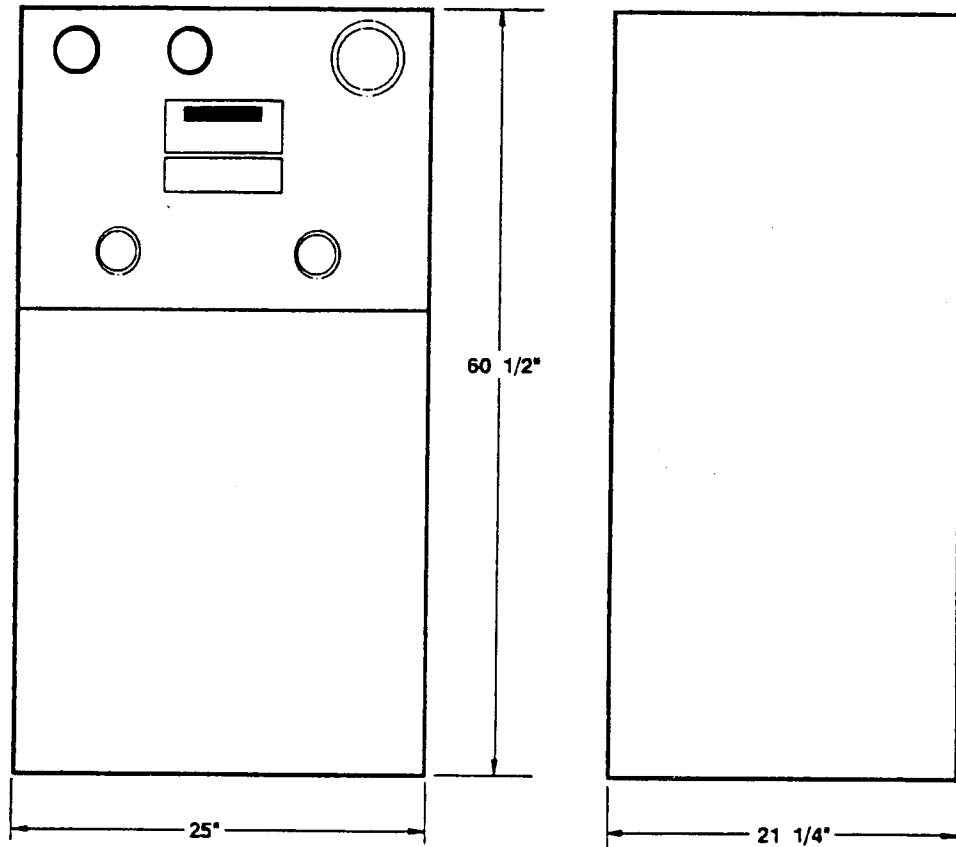

**PUREGAS P-06500D OUTLINE DIMENSIONS**  
**Figure 1**

## SECTION 2 DESCRIPTION

The Model P-06500D Air Dryer employs the principles of compression and physical adsorption. The operation is fully automatic and relatively maintenance-free. The unit essentially consists of two oilless air compressors and two heatless desiccant dryers. It also incorporates the necessary gauges, controls and automatic alarms to ensure the delivery of dry air at the proper pressure and relative humidity. The air dryer will automatically shut down in the event of a high humidity alarm. Outline Dimensions are shown in Figure 1, Page 2. Specific characteristics are shown in Chart 1, below.

PART NUMBER	P-06500D
NORMAL OUTPUT CAPACITY	1 Compressor/Dryer 3800 SCFD*
	2 Compressor/Dryer 7600 SCFD*
EMERGENCY OUTPUT CAPACITY	1 Compressor/Dryer 4750 SCFD*
	2 Compressor/Dryer 9500 SCFD*
DEWPOINT	below (-40° F.)
OUTPUT PRESSURE	Adjustable 0-17 PSIG
AIR COMPRESSOR SIZE	2 - 1 HP Oilless Piston Height: 60.5, Width: 25" Depth: 21 1/4"
POWER REQUIREMENTS	220/230 VAC, 1 PH, 50 HZ, 30 Amp Service Electrical options available for worldwide applications
STANDARD ALARMS AND INSTRUMENTATION	Discrete alarms with remote monitoring capability. Individual alarm indication
NOISE LEVEL	1 Compressor/Dryer: 55 dbA AT 3' 51 dbA AT 10'
	2 Compressor/Dryer: 60 dbA AT 3' 58 dbA AT 10'
WEIGHT	400 Lbs.
DEHYDRATOR	Solid State Timer/D.C. Valves
HEAT DISSIPATION	9200 BTU, Maximum
DRY AIR OUTLET CONNECTIONS	Low 1/2" FPT/High 1/2" FPT
* Standard Cubic Feet Per Day	

**PUREGAS P-06500D AIR DRYER CHARACTERISTICS**  
Chart 1

## SECTION 3 PRINCIPLES OF OPERATION

This unit has successfully completed a five day operational test at the factory. Each component was individually calibrated and tested over its full range of operation. The operation and existing settings are explained as follows:

### 3.1 Air System

The air flow is shown schematically in the Air Flow Diagram (Figure 2, Page 5).

### 3.2 Air Compressor

Ambient air is drawn through the intake filter on the air compressor and compressed to approximately 50 PSIG. It then passes to the precooler where hot compressed air is cooled before entering the heatless dryer. (Some moisture may collect in the precooler.) Some models are equipped with optional filter/automatic drain assemblies, which collect and remove liquid condensate and particles larger than 5.0  $\mu\text{M}$  prior to entering the heatless air dryers.

### 3.3 Heatless Dryer

The PUREGAS heatless dryer, which is located downstream from the air compressor, consists of two desiccant-filled towers, a manifold, a solid state timer and two solenoid valves. It is arranged and cycled so one tower delivers dry air to the cable system while the desiccant in the other tower is purged and dried by a small quantity of the dry air supplied by the first tower. Refer to The Theory of Heatless Drying Diagram (Figure 3, Pg. 6). The tower functions reverse at 30-second intervals. The towers operate as follows:

- 3.3.1 **Tower #1** - Air from the compressor enters the solenoid valve, which is controlled by an electrical timer and is forced upward through the desiccant in the tower. Moisture is removed from the air as it passes over the desiccant. The dried air is then forced down through the air tube in the center of the desiccant tower, out through an open ball check valve and is finally delivered through the capacity control valve to the air storage tank.
- 3.3.2 **Tower #2** - Simultaneously with the operation of Tower 1, as described above, the solenoid valve of Tower 2 is opened to the atmosphere. The main dry air supply from Tower 1 is prevented from entering Tower 2 by automatic closure of the ball check valve. However, a small quantity of the dry air is forced through an orifice into the air tube, then down through the desiccant bed absorbing the moisture previously collected while Tower 2 was furnishing dry air (as Tower 1 is doing at this time), and finally expelled to the atmosphere through the solenoid valve. The desiccant in Tower 2 is thus dried and made ready for the cycle reversal. Tower 1 and Tower 2 reverse functions; Tower 2 takes over the air drying operation while the desiccant in Tower 1 is being dried.

AIR FLOW DIAGRAM  
Figure 2

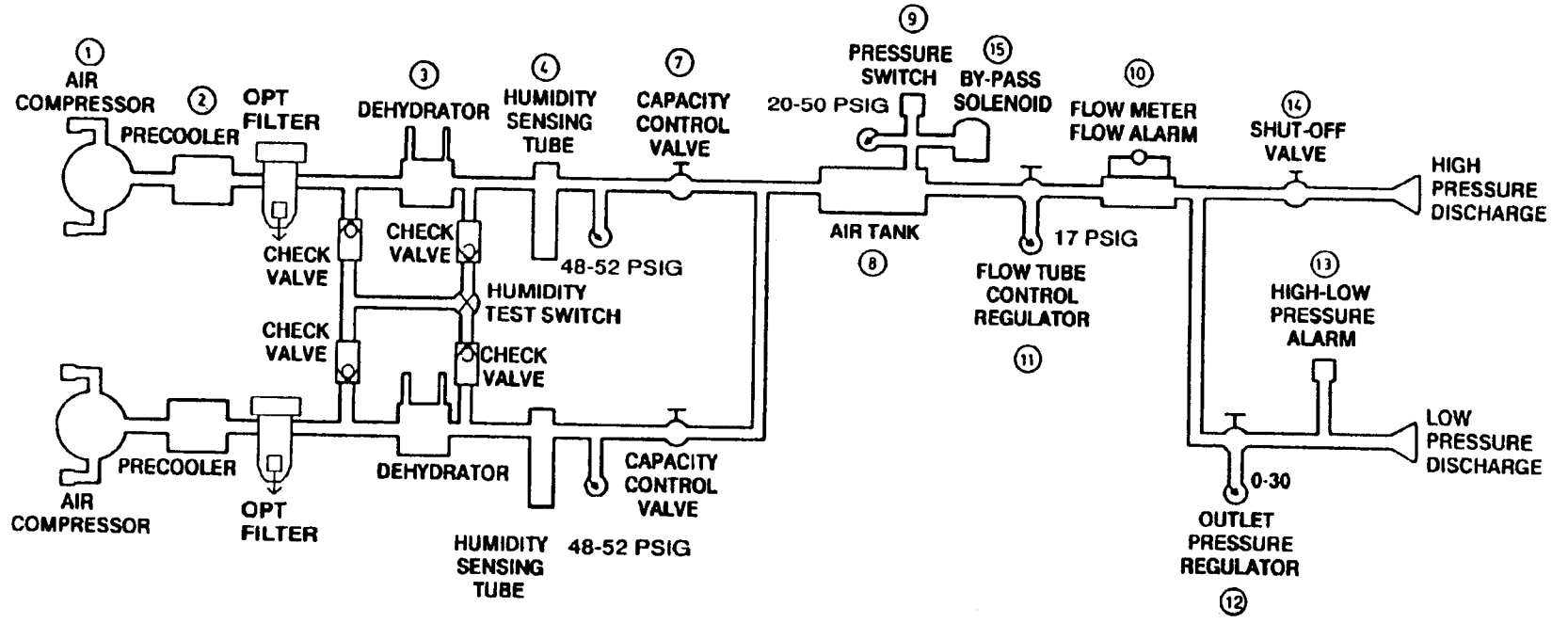

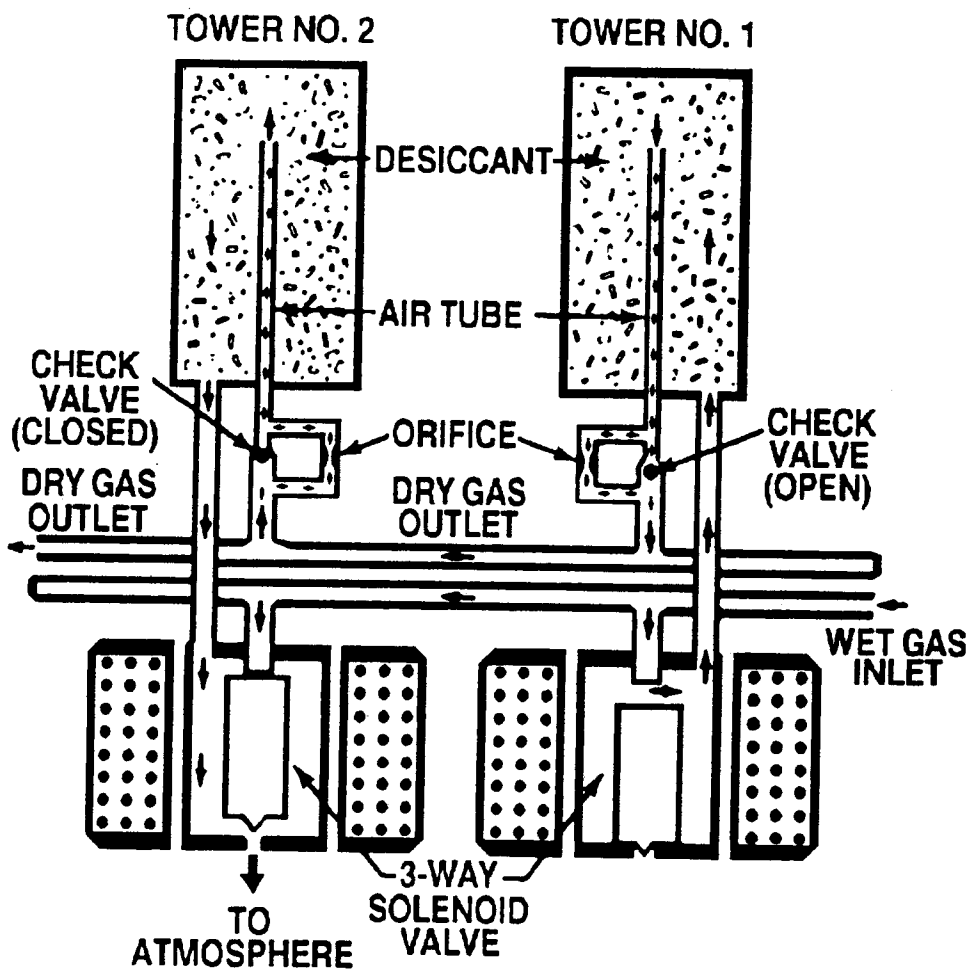

THEORY OF HEATLESS DRYING DIAGRAM  
Figure 3

### 3.4 Humidity Sensing Tube

Air is then channeled to the humidity sensing tube and flows over the humidity sensor. The humidity sensor (not shown) will signal the alarm systems if the relative humidity rises above 10%.

Note:

*To test the humidity systems, wet air from the precooler can be channeled directly to the humidity sensing tube by using the humidity test switch. A check valve is provided to prevent air from bleeding back.*

### 3.5 Capacity Control Valve

This valve has two functions. First, it maintains proper purge pressure through the heatless dryer, which will insure dry air delivery under maximum flow condition. It also acts as a check valve preventing air in the air storage tank from bleeding back through the heatless dryer when the air compressor is not operating.

### 3.6 Pressure Switch and Storage Tank

Once the air passes through the capacity control valve, it is directed to the air storage tank. The on/off pressure switch then signals the compressor to shut down at 50 PSIG. The air compressor will remain off until the tank pressure drops below 20 PSIG. Now the on/off pressure switch starts the air compressor and the cycle continues. The tank pressure gauge indicates actual air storage tank pressure. For adjustment refer to Section 6.4, Page 24 and Air Compressor Pressure Switch diagram, Figure 10, Page 24.

### 3.7 Flow Tube Control Regulator, Meter and Alarm

The main flow of air from the air storage tank is directed through an adjustable flow tube control regulator and associated 0-30 PSIG pressure gauge. The gauge should be set at 17 PSIG as controlled by the regulator. The function of the pressure regulator is to keep a constant pressure on the flow tube.

From the flow tube control regulator, the air is directed to the flow tube and associated flowmeter located on the front control panel. The flowmeter is calibrated from 0-8,000 SCFD. From the flow tube, a supply of air is directed to the shut-off valve and to the high pressure outlet.

### 3.8 Humidity Bypass Solenoid Valve

The air flows through the humidity bypass valve which allows dry air to pass into the cable or releases wet air into the atmosphere. The bypass solenoid valve will release wet air for a preset period of time to allow the air dryer to correct the wet air problem. If the dryer does not correct the wet air problem, it will shut down after this preset time period. The humidity bypass solenoid valve is activated by the humidity alarm circuit.

Note:

*When energized, the humidity bypass valve directs dry air to the cable. When de-energized, the valve bypasses air to the atmosphere.*

### 3.9 Pressure Regulator and Shut-Off Valve

From the air storage tank, the air is channeled to the high pressure outlet valve and the low pressure outlet which is regulated by the pressure regulator (0-17 PSIG).

### 3.10 High/Low Pressure Switch

Dry air will flow to the high/low pressure switch which signals an alarm if the pressure drops below or rises above a preset value. For adjustments of the pressure switch, refer to Section 6.5, Page 25 and High/Low Pressure Switch Diagram, Figure 11, Page 25.

### 3.11 Air Dryer - Auto/Manual Mode

The air dryer is designed to operate on one or two compressors for normal operation.

#### 3.11.1 Manual Mode

If both compressors are required to maintain normal cable system pressure and flow demands, the auto/manual switch must be in the MANUAL position, both compressor/dryer units operate simultaneously and are controlled by the system circuit breakers located on the front panel.

**IMPORTANT:** In the MANUAL mode with only one system circuit breaker in an ON position, the system with the circuit breaker in the OFF position is DISABLED.

### **3.11.2 Automatic Mode**

In the auto mode, each air compressor/dryer unit (System 1 and System 2) will operate alternately for a 24-hour period. If during the operation of the online system, a HUMI.-1 (HUMI.-2) or C.P.SYS.1 (C.P.SYS.2) alarm occurs, the off-line standby (O.S. SYS.1 or O.S. SYS.2) system will automatically energize and support the active system. If the alarm clears or is reset, the operating standby unit will de-energize and return back to a standby status mode.

### **3.11.3 24-Hour Cycle Start Switch**

When 24-hour cycle start switch is depressed, the system cycling clock will reset at hour 0, compressor/dryer system 1 will operate and system 2 will be off on standby (O.S. SYS.2 will be displayed), 24 hours later system 2 will be on-line and system 1 will be off on standby (O.S. SYS.1 will be displayed).



### 3.12 Alarm Summary

The following alarms and conditions can be shown on the digital alarm display:

#### 3.12.1 High Pressure Alarm - **HI PRES.**

This alarm results when the outlet pressure (as read on the outlet pressure gauge) exceeds the set point of the high pressure switch. The switch can be adjusted; however, it is factory set to alarm when the outlet pressure exceeds 12 PSIG. Refer to Section 6.5 and High/Low Pressure Alarm Switch Diagram, Figure 11, Page 25 for adjustment procedure.

#### 3.12.2 Low Pressure Alarm - **LOW PRES.**

This alarm results Low Pressure Alarm - when the outlet pressure drops below the set point of the low pressure switch. The switch is adjustable; however, it is factory set to alarm when the outlet pressure drops below 7 PSIG. Refer to Section 6.5 and Figure 11, Page 25 for adjustment procedure.

#### 3.12.3 Compressor Alarm - **C.P. Sys .1/C.P. Sys.2**

This alarm occurs when the air compressor and heatless dryer run time (between 20 PSIG and 50 PSIG) exceeds the set point of the solid state compressor performance time delay switch. The switch is adjustable; however, it is factory set at approximately two minutes. Refer to Figure 5 and 9 for adjustment.

#### 3.12.4 High Flow Alarm - **HI FLOW**

This alarm results when the air flow from the dryer exceeds the alarm setting on the flowmeter. This point is factory set at 8000 SCFD and is adjustable. Refer to Front Control Panel Diagram Figure 14, Page 35.

#### 3.12.5 Humidity Condition -**HC-**

During the time when -HC- is being displayed the following sequence occurs:

- A. The humidity bypass solenoid valve de-energizes and releases air from the storage tank into the atmosphere.
- B. The solid state humidity time delay switch starts counting down from its adjustable set point. The factory setting is one minute.
- C. -HC- is shown in the alarm display.

Note:

*If the humidity condition does not clear and humidity time delay "times out", the air compressor/heatless dryer will shut down and Humi.-1 or Humi.-2 will appear on the alarm display. If the humidity condition does clear, the bypass solenoid will energize and prevent air in the storage tank from being released into the atmosphere. The -HC- will disappear from the alarm display and the humidity time delay count will reset to zero.*

### 3.12 Alarm Summary (continued)

#### 3.12.6 Humidity Alarm - HUM1.-1 and HUM1.-2

This alarm will only be displayed after the -HC- (humidity condition) time delay has timed out. When an Humi.-1 or Humi.-2 humidity alarm is displayed, the air compressor and heatless dryer for the system in alarm will not operate.

#### 3.13 High Flow Alarm

The high flow alarm is activated when the flow exceeds 8000 SCFD. The alarm setting can be changed by rotating the right hand knob on the flowmeter which will locate the alarm pointer to the desired position.

#### 3.14 Humidistat

The humidity level is represented by the five LED's (three red and two green) for each system located just below the alarm display. When all LED's are energized, the humidity level is less than 2% relative humidity, indicating the system is operating correctly.

#### 3.15 Dessicant

During shipment, the desiccant in the heatless dryer towers may have absorbed some moisture. If this is the case, one or more LED's may be off during initial start-up; however, they will come on as the desiccant "dries out" during operation. All LED's on the humidistat should be energized after 15 minutes of operation.

#### 3.16 Logic Scan LED

The logic scan LED will pulse on and off whenever the dryer is turned on. This indicates the display board is scanning for alarms.

#### 3.17 Alarm LED

The alarm LED is normally off. It will only energize when an alarm condition is present on the digital alarm display.

Example:

The alarm LED will energize during the following alarm conditions: Low Pres., Hi Pres., C.P. Sys.1, C.P. Sys.2 and Humi.-1, Humi.-2 and Hi Flow. The alarm LED will not energize when -HC- is displayed or when the digital alarm display is blank.

## SECTION 4 INSTALLATION AND START-UP

**CAUTION:**  
It is extremely important to perform the installation, start-up and test procedures in Sections 4 and 5 in the following sequence or damage to components may result and warranty voided.

### 4.1 Inspection

Remove the lower front door and open the upper instrument panel. Carefully inspect both the exterior and interior of the air dryer for any shipping damage.

#### **IMPORTANT!**

**Any damage must be brought to the immediate attention of the carrier. Manufacturer is not responsible for shipping damage.**

### 4.2 Accessories

The following items will be secured in the air compressor compartment accessory bag:

2 each	P-B-104	Allen Wrench 3/16" - Long Arm
4 each	P-3986	Filter Felt
1 each	P-5000-3-19	Bag, Cloth 5" x 8"
1 each	P-5000-8-38	Plug Alarm
1 each	P-5000-8-39A	Boot Alarm Socket

### 4.3 Installation Procedure

4.3.1 Close the upper instrument panel and install the lower panel before moving unit to the permanent location.

4.3.2 Remove shipping blocks. This permits the assembly to "float" freely on the rubber vibration pads.

#### **Note:**

*Failure to remove the shipping blocks may damage the mounting assembly.*

4.3.3 Leveling feet are located under each corner of the air dryer. The air dryer must be properly leveled to prevent excessive vibration and to insure proper alignment of the access panels.

#### 4.4 Location

4.4.1 The unit should be installed in an environment free from abrasive dust and chemicals.

4.4.2 The optimum temperature range is between 40° and 85° F. Although the unit will operate at temperatures up to 110° F., the operating life of the components decreases dramatically at temperatures above 85° F.

#### 4.5 Electrical Hook-up

4.5.1 The air dryer operates on 208 or 220 VAC, 1 phase, 60 cycle power.

**Important!**

**A 30 amp service must be provided. The incoming power to the dryer should have 20 amp SLO-BLO fuses. A minimum of 12 AWG wire must be used to connect to the dryer.**

4.5.2 Before plugging the air dryer in to the electrical outlet, make sure the main power switch is in the OFF position.

4.5.3 Connect the air dryer to the proper electrical source.

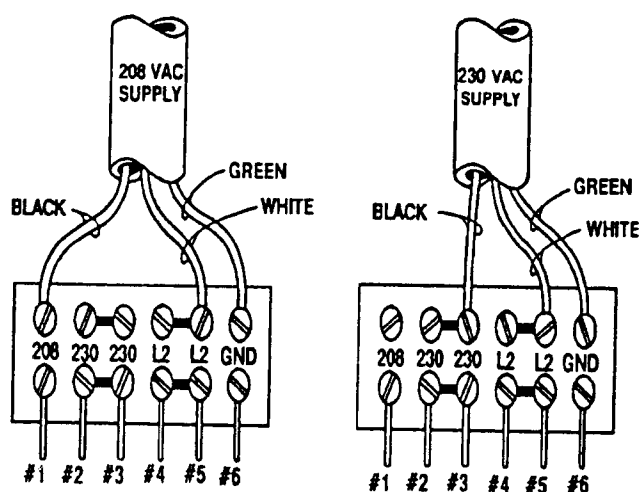

**ELECTRICAL HOOK-UP**

**Figure 4**

## 4.6 Start Up

- 4.6.1 A plastic plug with a small hole (orifice plug) is located in the low pressure outlet port at the rear of the air dryer. This plug will permit the unit to operate in a simulated "on-line" condition.
- 4.6.2 Refer to the logic circuit board on the reverse side of the gauge panel. Verify that the auto-manual switch is in the manual position. On the front gauge panel, place the System 1 and System 2 switches in the ON position. See Logic Board Diagram, Figure 5, Page 15, and Reverse Control Panel Diagram, Figure 15, Page 36.
- 4.6.3 Place the main power switch to the "ON" position.
- A. The logic scan LED will start flashing.
  - B. The air compressors, heatless dryers and ventilating fans will start running and air will flow through the orifice in the low pressure outlet.
  - C. Toggle the reset switch to clear erroneous alarms.
  - D. Low Pres. (Pressure Low) will appear on the alarm display until the outlet pressure gauge reads approximately 8 PSIG or more. During the time Low Pres. appears on the display, the alarm LED will also be energized.
  - E. -HC- (Humidity Condition) may appear on the alarm display. If -HC- does not clear within approximately one minute, Humi.-1 will appear in the alarm display and the air compressor will shut down. If this happens, simply toggle the reset switch. This will allow the unit to run for approximately one more minute. The -HC- should clear within 10-15 minutes.
  - F. The five humidity level LED's for each system will energize when the desiccant in the heatless dryer is dry. If, however, during initial start-up, -HC- appears in the alarm display, one or more LED's will be off. The LED's will energize as the dessicant dries out. This should take less than 15 minutes.
  - G. The outlet pressure gauge will stabilize at approximately 10 PSIG.
  - H. The air pressure in the air storage tank will cycle between 20 and 50 PSIG as noted on the tank pressure gauge.
  - I. The alarm LED will be energized only when the Low Pres., Hi Flow, Hi Pres., C.P. Sys.1, C.P. Sys.2, Humi.-1 or Humi.-2 appears on the alarm display. The alarm LED will be off in all other cases.
  - J. Check for pressure leaks that may have occurred during shipment.

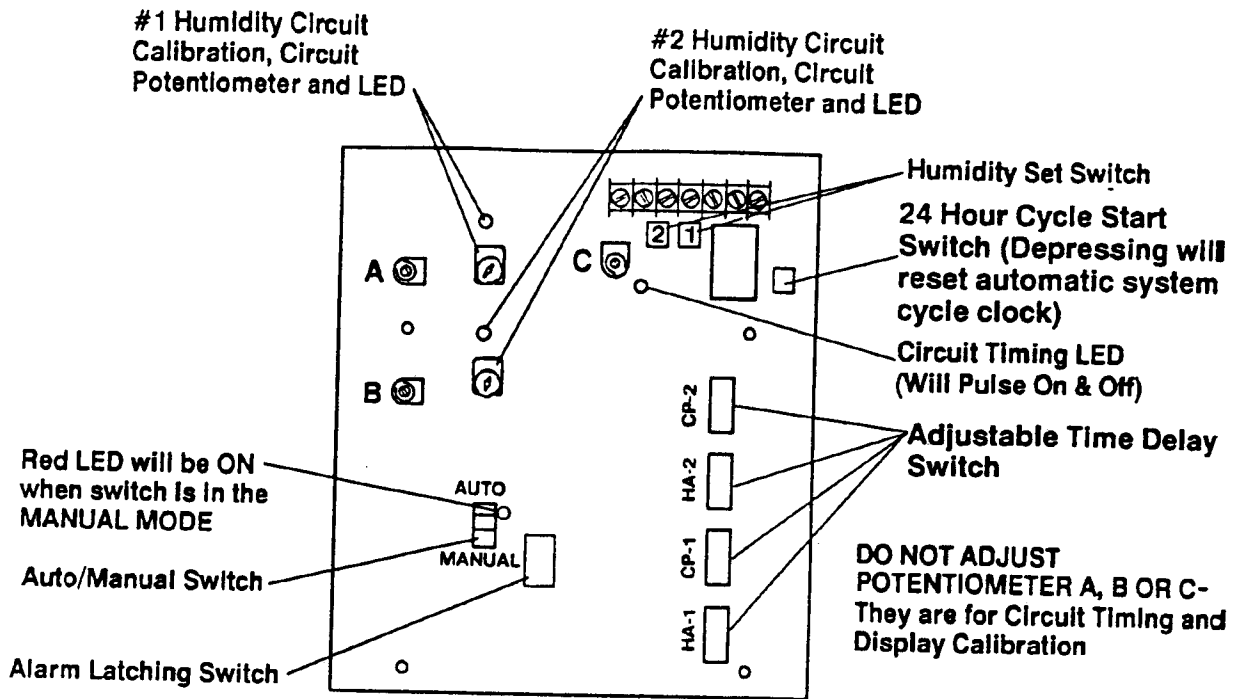

**LOGIC BOARD**  
Figure 5

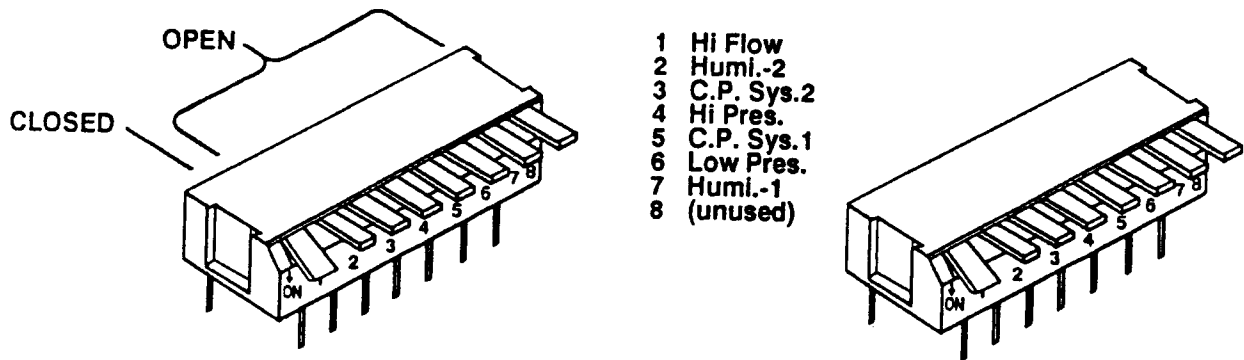

**LATCHING ALARM D.I.P. SWITCH**  
Figure 6

Note:

The latching alarm switch, located on logic board, Figure 5, above, only latches the alarm on the display of the dryer and not out to the central office. In the event of an alarm, if left in the latch position, the display will tell what kind of alarm it is.

## SECTION 5 TEST PROCEDURES

**DANGER:**  
**Avoid contact with energized circuits when access doors are open.**  
**REMOVE ALL JEWELRY before performing any tests or maintenance**  
**on air dryer.**

With the air dryer in operation, perform the following tests:

### 5.1 Low Pressure Alarm Test

- 5.1.1 Remove the bottom door and open the front instrument panel.
- 5.1.2 Locate the outlet pressure regulator - Heatless Dryer, Top Control Panel Diagram, Figure 17, Page 38) and pull the locking collar on the knob out so that the regulator can be adjusted.
- 5.1.3 Rotate the knob counterclockwise and reduce the pressure on the outlet pressure gauge to approximately 5 PSIG.
- 5.1.4 At this point, Low Pres. will appear in the alarm display. Turn the handle clockwise and increase the pressure on the outlet pressure gauge to 10 PSIG. Low Pres. will disappear from the alarm display. Alarm set point is set from the factory at 7 PSIG.

### 5.2 High Pressure Alarm Test

- 5.2.1 Rotate the knob on the pressure regulator clockwise until the outlet pressure gauge reads approximately 15 PSIG. Hi Pres. will appear at the alarm display.
- 5.2.2 Reduce the pressure back to 10 PSIG. Toggle the reset switch and Hi Pres. will disappear. Alarm set point is set from the factory at 12 PSIG.

### 5.3 Humidity Condition Test

- 5.3.1 Locate the Humidity set switches on the logic printed circuit board (refer to Logic Board Diagram, Figure 5, Page 15. Depress #1 switch for 1 minute, until -HC- turns into Humi.-1 on display. This tests the electronics only. Repeat this procedure for system 2.

- 5.3.2 Place the #1 switch in the ON position (closed) and switches 2 through 8 in the OFF position (open). This represents an approximate one-minute time delay before a humidity condition (HC) will turn into a humidity alarm (Humi.-1 or Humi.-2).

Note:

Only one switch should be in the closed position at any one time. Figure 7 below, shows the #1 switch in the CLOSED position.

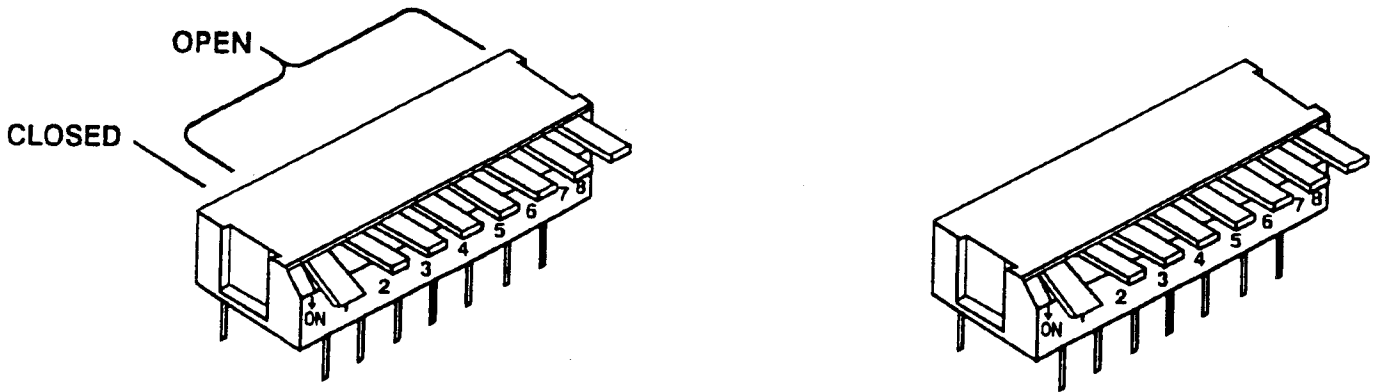

**HUMIDITY TIME DELAY SWITCH**  
**Figure 7**



- 5.3.3 Locate the humidity test switch on the front of the instrument panel. With the air compressor running, toggle and hold down the humidity test switch in the "System 1" position. Notice the five humidity LED's for System 1. These LED's should begin to de-energize. -HC- will appear in the alarm display and the humidity bypass solenoid will discharge the air in the air storage tank to the atmosphere. Release the test switch.

Please note the following:

- A. The alarm LED will not energize during an -HC- (humidity condition).
- B. The System 1 air compressor must be running during this test.
- C. In areas where relative humidity is normally low (i.e., 5% relative humidity), it may be necessary to use the humidity set switch (refer to Humidity Set Switch on the Logic Board Diagram, Figure 5, Page 15) for location.

- 5.3.4 The above test confirms the operation of the following humidity system components:

- A. Humi-Alarm circuit
- B. Humidity bypass solenoid
- C. LED humidity display
- D. Humidity sensing element
- E. Associated wiring

#### 5.4 Humidity Alarm Test

- 5.4.1 A humidity alarm will result after a system has remained in Humidity Condition (-HC-) for longer than the time set on the humidity time delay switch (in this case, longer than one minute).
- 5.4.2 To perform this test, simply keep the dryer in a Humidity Condition (-HC-) for longer than one minute. This can be accomplished by holding the humidity test switch down on System 1.

- 5.4.3 After the dryer has been in a Humidity Condition (-HC-) for longer than one minute, the following sequence will occur:
- A. -HC- Humidity Condition will appear in the alarm display.
  - B. Humi.-1 Humidity Alarm will appear in the alarm display.
  - C. O.S. Sys.1 on Standby-1 will appear in the alarm display.
  - D. The alarm LED will be on while Humi.-1 appears in that display.
  - E. The air compressor #1 will shut down.
  - F. The two green humidity LED's (and possibly some or all red LED's) will de-energize on the System 1 humidity display.
  - G. The two outside green LED's on the SSR Board, (Figure 8, Page 19), will be energized when both compressors are running. The center LED will be energized unless there is a Humidity Condition -HC-.
- 5.4.4 Release the humidity test switch. The following sequence should occur:
- A. The five humidity LED's will begin to energize.
  - B. By the time the green humidity LED's have energized, air compressor #1 will start running. Humi.-1 and O.S. Sys.1 will disappear from the display.
  - C. -HC- will remain in the display and the humidity bypass solenoid will continue to pass the air until the humidity time delay automatically resets (approximately one minute).
- 5.4.5 Repeat the above sequence for System 2.

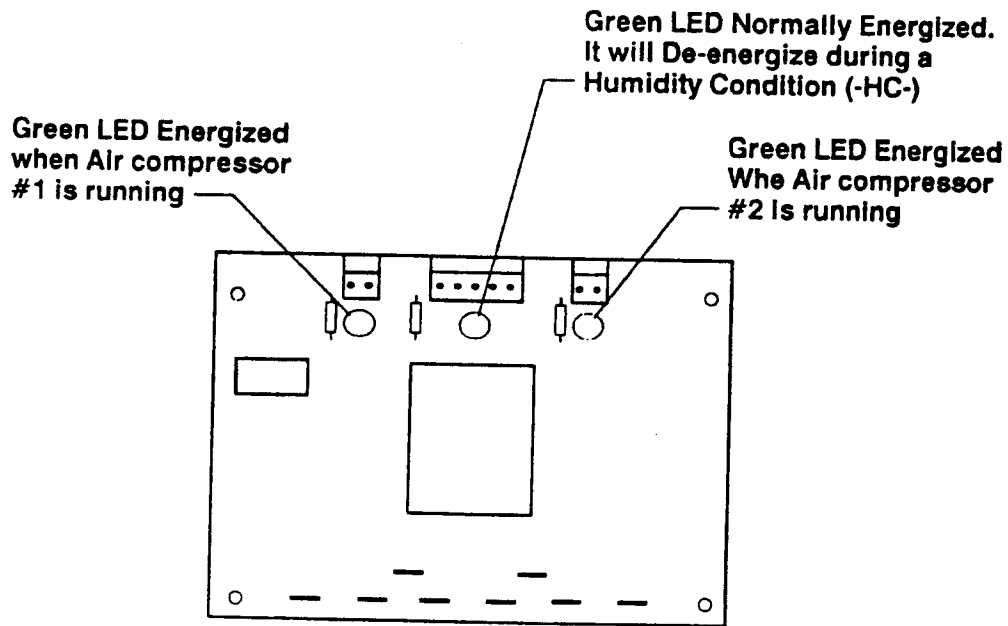

SSR BOARD  
Figure 8

## 5.5 Compressor Performance Test

5.5.1 A compressor performance alarm (C.P. Sys.1 or C.P. Sys.2) will result when the air compressor remains running for a period which is longer than normal for a particular installation.

Example:

If the normal flow of air is approximately 1200 SCFD (as read on the flow meter) and the time between the air compressor starting and stopping (the 20-50 PSIG pressure cycle) is 1 1/2 minutes, then the normal running time is 1 1/2 minutes.

5.5.2 With the normal cycle at 1 1/2 minutes, the C.P. Sys.1 and C.P. Sys.2 compressor performance time delay switches (located on the logic printed circuit board), should be set with the #2 switch CLOSED and all other switches in the OPEN position. See Compressor performance Time Delay Switch Diagram, Figure 9, Page 21.

5.5.3 With the above conditions set, a compressor performance alarm (-CP-) will appear on the alarm display if, for any reason, the air compressor runs continuously for a period exceeding two minutes.

Note:

*The compressor performance time delay is factory set at 2 minutes.*

The following items represent some possible reasons a -CP- alarm would be displayed:

- A. An increase in flow to pipes or cables.
- B. A leak in the internal pneumatic connections in the air dryer.
- C. A "weak" air compressor.
- D. A faulty solenoid valve in the heatless dryer.

Refer to Troubleshooting Guide, Section 7.0, Page 40 for further details.

5.5.4 To test the CP alarm, simply create a temporary leak in the dryer which will force the air compressor to run longer than two minutes. After approximately two minutes, CP will appear on the alarm display.

5.5.5 Terminate the temporary leak and clear the C.P. Sys.1 and C.P. Sys.2 alarms from the alarm display by toggling the reset switch.

Note:

*All Installation, Start Up and Test Procedures (Sections 4 and 5) must be completed in the order listed above or damage to components may result and warranty voided.*

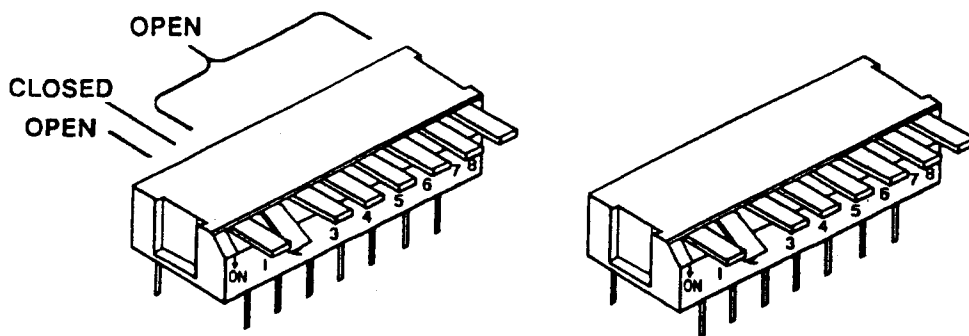

**COMPRESSOR PERFORMANCE TIME DELAY SWITCH**  
Figure 9

## SECTION 6 MAINTENANCE

### 6.1 Routine Maintenance

The following is the maintenance procedure recommended by PUREGAS. If maintenance problems persist after thoroughly consulting this manual, contact General Cable Company, Apparatus Division, Puregas Technical Service Department at (303) 427-3700 or 1-800-521-5351.

**CAUTION:**

**When working around energized circuits, extreme caution should be taken to prevent injury to personnel and damage to equipment.**

**IMPORTANT!**

It is very important that routine maintenance be performed at six-month, one-year (or 4,000 hours), and two-year (or 8,000 hours) intervals to keep dryer operating efficiently. PUREGAS recommends a historical record be maintained on all air dryers.

#### 6.1.1 Six Month Check

Every six months, do the following:

- . Check flow rate (compare to previous flow rate)
- . Check humidity alarm
- . Check safety valve
- . Check pressure switch
- . Check high/low pressure alarm
- . Check capacity control valve
- . Check cabinet filters
- . Change inlet filters
- . Replace the air compressor intake filter felts (P-3986)
- . Clean the air precoolers
- . Clean or replace cabinet filter element (P-06131)
- \* . Clean or replace air filter elements (P-07765)
- \* . On models equipped with optional filter/automatic drain assemblies.

#### 6.1.2 One Year (or 4,000 hours)

- . Change the compressor maintenance kit (P-07589) after one year or 4,000 hours. Refer to Page 34 for parts list
- . Check all wire connections
- . Repeat 6 month check

**6.1.3 2 Years (or 8,000 hours)**

- Change heatless dryer maintenance kit, P-200-499S, (refer to Page 33, Exploded View of Heatless Dryer, Figure 12 and Page 33, Ordering Information for Heatless Dryers). Refer to Page 32 for Parts Breakdown.
- Repeat 6 month check
- Repeat one year check

Note:

After performing maintenance on air dryers, always soap test pressure fittings to insure there are no leaks. Wiring should be checked on a routine basis whether maintenance has been performed or not.

**6.2 Maintenance Matrix**

	Maintenance Procedure (Refer To Manual)	Frequency Interval	Time (minutes) Required
	=====	=====	=====
Emergency Standby	Check	A	5
Automatic Cycling	Check	A	5
Flowrate	Check	A	1
Humidity Alarms	Check	A	5
High/Low Pressure Alarm	Check	A	5
Compressor Pressure Switch	Check	A	5
Safety Valve	Check	A	5
Output Regulator	Check/Adjust	A	5
Ventilation Filter	Replace/Clean	A	10
Compressor Intake Filter	Replace	A	5
Compressor Performance	Check	A	5
Capacity Control Valve	Check	A	5
Precooler Coils	Clean	A	10
Air Fittings	Leak Test	A	10
*Air Compressor Kit	Replace	B	5
*Humidity Sensing Element	Replace	B	60
Heatless Dryer Kit	Replace	C	5
Humidity and Compressor Performance Delay	Check	A	10
* * Filter Element, 5 micron	Clean/Replace as needed (P-07765)	A	5

Frequency Interval

- A - Every 6 months
- B - 1 year (or 4,000 hours)
- C - 2 years (or 8,000 hours)

Note:

The part number for annual compressor maintenance kit is P-07589.  
 The part number for the heatless dryer maintenance kit is P-200-499S.  
 \*These components are supplied in the annual maintenance kit.  
 \*\*On models equipped with optional filter/automatic drain assemblies.

**P-06500D Maintenance Matrix  
Chart 2**

### 6.3 Air Compressor Safety Valves

The air compressor safety valves are factory preset to prevent the air compressor from delivering air over 55 PSIG. Check for proper operation. If adjustment is required, use the following procedure:

- 6.3.1 Locate the capacity control valves (See Heatless Dryer Top Control Panel, Figure 17, Page 38) and lift up the valve lock collar. Turn the valve clockwise until 60 PSIG is noted on the pressure gauge. Adjustment must be made while the compressor is running.
- 6.3.2 Referring to the same drawing, loosen the safety valve lock nut and adjust the valve until the maintained pressure is 55-60 PSIG and the relief valve is releasing air. Once adjustment is made to 55-60 PSIG, retighten the safety valve lock nut.
- 6.3.3 Readjust the capacity control valve to 48-50 PSIG. Insure the storage tank has at least 20-30 PSIG air pressure and the air compressor is running while adjusting. Press the lock collar down into the lock position.
- 6.3.4 Allow the compressor to cycle through the cycling pressure range several times and soap test to insure the air compressor safety valve has seated properly and is not leaking.

### 6.4 Air Compressor Pressure Switch

The on/off pressure switch is factory set to stop and start the air compressor and maintain the pressure in the air storage tank. The pressure in the tank should cycle between 20-50 PSIG ( $\pm 2$  PSIG), as noted on the high pressure gauge (tank pressure). To adjust the on/off switch, refer to Air Compressor Pressure Switch Diagram, Figure 10, below.

#### ADJUST IN PROPER SEQUENCE

STEP NO. 1

RANGE ADJUST  
Turn down for higher  
cut-in pressure, or  
up for lower cut-in

STEP NO. 2

DIFFERENTIAL ADJUST  
Turn down for higher  
cut-out, or up for  
lower cut-out

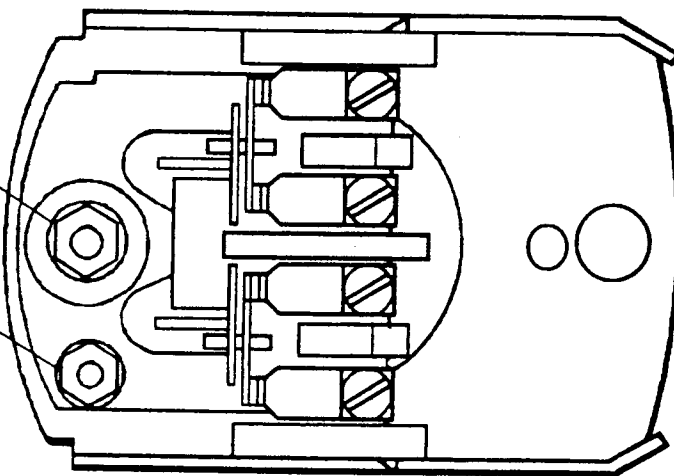

**AIR COMPRESSOR PRESSURE SWITCH**

Figure 10

### 6.5 High/Low Pressure Alarm Adjustment

The high/low pressure switch is located in the air output. To adjust, use the pressure regulator and refer to High/Low Pressure Switch Diagram, Figure 11, below.

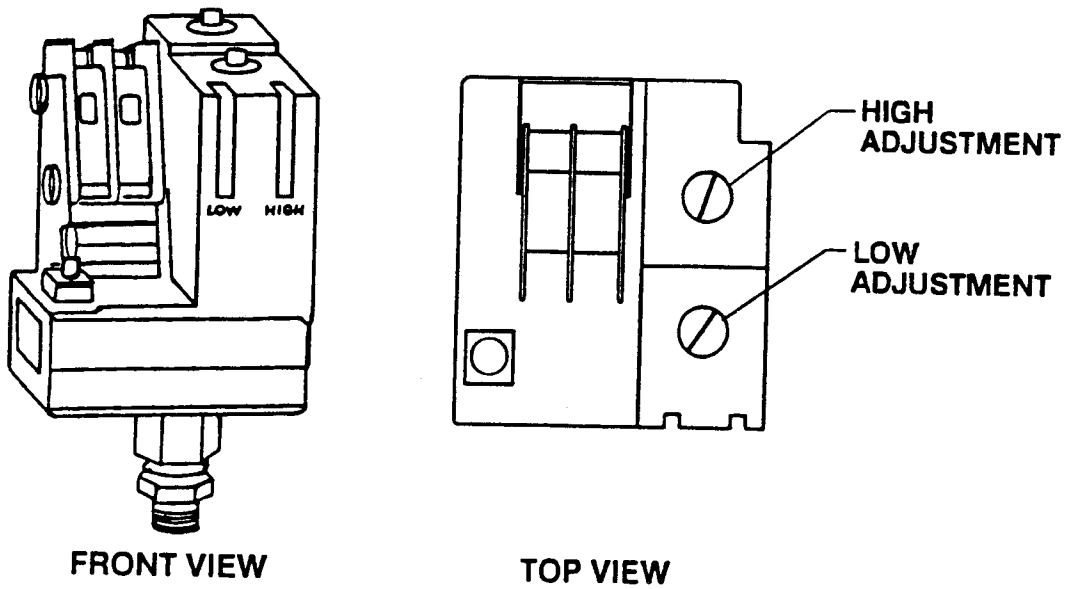

**FIGURE 11  
HIGH/LOW PRESSURE SWITCH**



## 6.6 Capacity Control Valve Adjustment

To adjust the capacity control valve make sure the air compressor is running and the tank pressure is between 20-30 PSI. Lift up on the valve lock collar and adjust the valve handle clockwise until 48-50 PSIG is read on the heatless dryer gauge which is mounted on the heatless dryer manifold. Then press locking collar back in place. Refer to Heatless Dryer Top Control Panel Diagram, Figure 17, Page 38.

## 6.7 Air Compressor Maintenance Kit

The P-07589 maintenance kit contains parts necessary for scheduled routine maintenance on the P-06500D air dryer when operated under normal conditions. The contents of the maintenance kit are as follows:

<u>Part No.</u>	<u>Description</u>	<u>Qty Ea.Kit</u>
P-3861	Piston Seal	8
P-3862	Piston Ring	8
P-3864	Manifold Sleeve	4
P-3866	Head Gasket	4
P-3867	Outlet Valve	4
P-3868	Inlet Valve	4
P-3869	Cylinder Gasket	4
P-3870	Valve Plate	4
P-3981	Rider Ring	4
P-3986	Filter Felt	8
P-07510	Pressure Switch kit	1
P-5000-6-47D	Sensing Element	2

### **IMPORTANT!**

**If the air compressor shows evidence of overheating or excessive noise, stop immediately for repairs.**

Regular inspection may prevent expensive repairs. The rider ring thickness can be an indication that the air compressor needs maintenance. See Exploded View of Air Compressor and Motor Assembly, Figure 13, Page 34. If a rider ring measures .055 inches or less in thickness, the maintenance kit, P-07589 should be installed. The thickness of a new rider ring is .060 inches.

## 6.8 Optional Equipment

### Filter/Auto Drain Assemblies Kit

The function of the optional inlet filter/drain assembly, is to collect and remove liquid condensate and particles larger than 5.0 u.M. contained in the compressed inlet air.

P-07765 (Replacement element for above option)

### 6.9 Air Compressor Troubleshooting Chart

The wear of the air compressor rings are affected by ambient conditions. At 80° to 85° F. maximum ambient temperature and 40% (maximum average) relative humidity, it is suggested the compressor life between maintenance checks be set at approximately 4,000 hours of run time.

Note:

At higher ambient temperatures, maintenance must be performed more frequently.

The air compressor is oilless and requires no lubrication. It is recommended the piston rings, piston seals, rider rings, inlet valves, outlet valves, valve plate and gaskets be replaced at 4,000 hours of run time.

REASON	COMPLAINT			
	Low Pressure	Overheating or excessive AMP Draw	Excessive Noise	Won't Start Under Load
Worn Piston Rings	X			
Worn Rider Rings	X		Piston Hitting Cylinder	
Dirty Valves	X			
Bent Valves	X			
Blown Head Gasket	X		Air Blowing Out Intake Filter	
Dirty Filters	X			
Low Voltage		X		X
Cylinder Mis-adjustment		Piston Hitting Intake Valve	Piston Hitting Intake Valve	X
Leaky Connections	X			
Relief Valve Set Too High		X		
Relief Valve Set Too Low	X			
Wrong Voltage Hookup		X	X	X
Dirt or Liquid in Top of Piston	X	X	X	X

**AIR COMPRESSOR TROUBLESHOOTING CHART**  
Chart 3

## 6.10 Air Compressor Disassembly

- 6.10.1 Remove or loosen the four screws which secure the fan shroud to the motor and slide the shroud off. Remove the four cylinder head bolts and separate them from the cylinder bolts. Remove the air manifold tube and the cylinder head with the valve components.

Note:

*Head bolts are different than cylinder bolts.*

- 6.10.2 Remove the two cylinder bolts at the motor and lift the cylinder off the piston.
- 6.10.3 Remove the piston rings, springs and rider rings.
- 6.10.4 Clean all components with non-flammable, non-toxic cleaning solvent.

**CAUTION:**  
**DO NOT FLOOD THE PISTON WRIST PIN OR CONNECTING  
ROD MAIN BEARING WITH SOLVENT OR THE PERMANENT  
LUBRICANT WILL BE WASHED AWAY.**

- 6.10.5 The head gaskets may have become firmly attached to the flat surfaces of cylinder heads or cylinders. Remove the old gasket material. Use No. 240 grit emery cloth (or wet/dry abrasive material) to flat-sand the cylinder surfaces. Follow with No. 400 grit emery cloth (or wet/dry) to dress these flat surfaces before reassembly with new gaskets.

## 6.11 Air Compressor Assembly

- 6.11.1 Install the new piston springs, rings and rider rings on the piston. Locate the ring joints approximately 180° opposite each other.
- 6.11.2 Attach cylinder to motor with cylinder bolts and lock washer and finger tighten bolts. Move the piston to the top dead center position and adjust the cylinder flush with the top of the piston.

Note:

*Top dead center can be checked by using a straight edge across the cylinder head and then move piston flush with the straight edge. Move piston up and down to insure there is no binding in the cylinder and tighten the cylinder bolts.*

- 6.11.3 Install valve components, gaskets and valve plate by lining them up as shown in Exploded Air Compressor and Motor Assembly Diagram Figure 13, Page 34. Valves are pre-lined in the maintenance kit; however, they should be checked. The leaves of the intake and discharge valves have been pre-bent and do not require adjusting. Check to make sure the leaves are bent away from the valve plate.
- 6.11.4 Install the head assembly using the four head bolts and finger tighten.
- Note:*  
*The ends of two fins on the cylinder head have been omitted. They are always on the exhaust port.*
- 6.11.5 Install new manifold seals on the manifold and assemble to the elbow fitting on the head assembly. **DO NOT TIGHTEN!**
- 6.11.6 Install the second head assembly and assemble the manifold. Tighten all head bolts and manifold nuts. (Head bolts are 150-160 inch pounds.)
- 6.11.7 Soap test all fittings with compressor running. A small amount of air will bleed around the heads.
- 6.12 Heatless Dryer**  
Open the front panel. No adjustments are necessary on the heatless dryer. No lubrication is required. It is recommended, however, that at intervals the unit be inspected as follows:
- The heatless dryer has a solid state timer which switches power to the solenoid valves from one tower to the other every thirty seconds. This can be heard as an air purge. If this air purge cannot be heard, refer to the Troubleshooting Guide , Section 7.5, Page 48-49, for correct diagnosis.
- At two-year intervals (or 8,000 hours) install maintenance kit P-200-499S in each dryer. Refer to Figure 12, Exploded View of Heatless Dryer (Page 33). The procedure is as follows:
- 6.13 Pressure Regulator**  
No preventative maintenance is required; however, if the pressure regulator becomes erratic or inoperative, it should be replaced.
- 6.14 Bypass Solenoid Valve**  
The bypass solenoid valve does not require maintenance.
- Note:*  
*It is normal for the bypass solenoid valve to be hot during operation.*

## 6.15 Humidity Alarm

If unit is in humidity alarm:

- 6.15.1 Unplug the sensing element cord from the humidistat assembly. The alarm system should clear. If alarm does not clear, continue with next step.
- 6.15.2 Hold down the set switch on the humidistat assembly and turn the circuit board adjustment potentiometer until the humidity alarm system starts. Release the switch and the alarm set point is now calibrated.
- 6.15.3 If the unit does not respond correctly, the humidity board is faulty and the logic board should be replaced. Refer to Troubleshooting Guide, Section 7.3, Page 45-46 for further information.

**WARNING:**  
**DO NOT MEASURE SENSING ELEMENT RESISTANCE OR IN ANY WAY APPLY D.C. VOLTAGE TO THE SENSING ELEMENT.**

- 6.15.4 Reconnect the sensing element cord that was disconnected in the first step. With the air compressor running, check the setting and operation of the capacity control valve (48-50 PSIG). See Paragraph 6.6, Page 26. If the capacity control valve is set low, the performance of the heatless dryer may suffer. If the capacity control valve is set high, the air compressor may overheat. If the alarm energizes again, replace the sensing element (P-5000-6-47D).
- 6.15.5 If the new sensing element does not clear the alarm, a failure in the heatless dryer is indicated. Refer to Section 7.5, Pg. 48-49, Parts List, Page 32 and Figure 12, Page 33.
- 6.15.6 Listen for strong air purge every 30 seconds ( $\pm$  or 1.5 seconds). If no purge occurs, proceed to 6.14.7. If purge occurs every 60 seconds proceed to step 6.14.8. If purge occurs every 30 seconds, replace the check balls and core assemblies and clear the purge orifices with an air gun. Refer to Figure 12, Page 33.

**6.15.7** Remove the terminal cover and check for 220/230 VAC at L1 & L2. If 220/230 VAC is present, verify 106 VDC is alternately being applied from DC1 to L2 for 30 seconds, then DC2 to L2 for 30 seconds. If this is not happening, replace the Solid State Timer.

If the air dryer is still in humidity alarm after the above steps have been completed, contact General Cable Company, Puregas Technical Service Department.

## 6.16 Dehydrator Parts List

Chart 4 Part Numbers refer to HF2C Series Dryers with Solid State Timers. Reference Numbers refer to parts shown in Figure 12, Page 33, Exploded View of Puregas Heatless Dryer (Dehydrator) (Solid State Timer Model).

<u>Reference Number</u>	<u>Description</u>	<u>Qty.</u>	<u>Part Number</u>
1	Desiccant Chamber (12") Assy.	2	P-200-403-12
2	O-Ring (included in above)	2	P-400-312-924
3	O-Ring	2	P-400-313-110
4	Purge Orifice	2	P-200-404-45
5	O-Ring	2	P-400-312-908
6	Ball, Check Valve	2	P-400-375
7	Plug, Hex	1	P-400-307-4
8	O-Ring	2	P-400-312-904
9	Nameplate	1	P-300-737
10	Drive Screw No. 4 x 3/16"	2	P-400-322-1
11	Screw, No. 10-24 x 5/8"	6	P-400-361-2
12	Pipe Plug, 1/4"-18 socket	2	P-400-320-3
13	Mounting Bracket	2	P-300-497-P
14	O-Ring	4	P-400-313-209
15	Air Manifold	1	P-300-495-P
16	O-Ring	2	P-400-313-018
17	Sol. Valve Assy., 106 VDC (for 220 VAC 50/60 Hz Dryers)	2	P-07990DC2
18	Solenoid Valve Maintenance Kit	2	P-200-498S
22	Screw No. 6032 x 3/8" P.H.	2	P-400-361-1
23	Screw No. 3-32 x 1" B.H.	2	H-SB83-OHC-10
24	Screw No. 6-32 x 1 1/4" B.H.	2	H-SB83-OFC-04
25	Nut, Keps 8-32	2	H-NK01-OHC-R5
26	Screw No. 6-32 x 1/2"	2	H-SB83-OFC-02
27	Decal Terminal Cover	1	P-06498
28	Cover Terminal	1	P-06499
29	Solid State Timer, 220V, 50/60 Hz	1	P-06521-F2
30	Bracket, Mtg. S/S Timer	1	P-06497
31	Plate, Adapter, S/STimer	1	P-06496
42	Spring, Check Ball	2	P-300-507

### DEHYDRATOR PARTS LIST (SOLID STATE TIMER MODEL) Chart 4

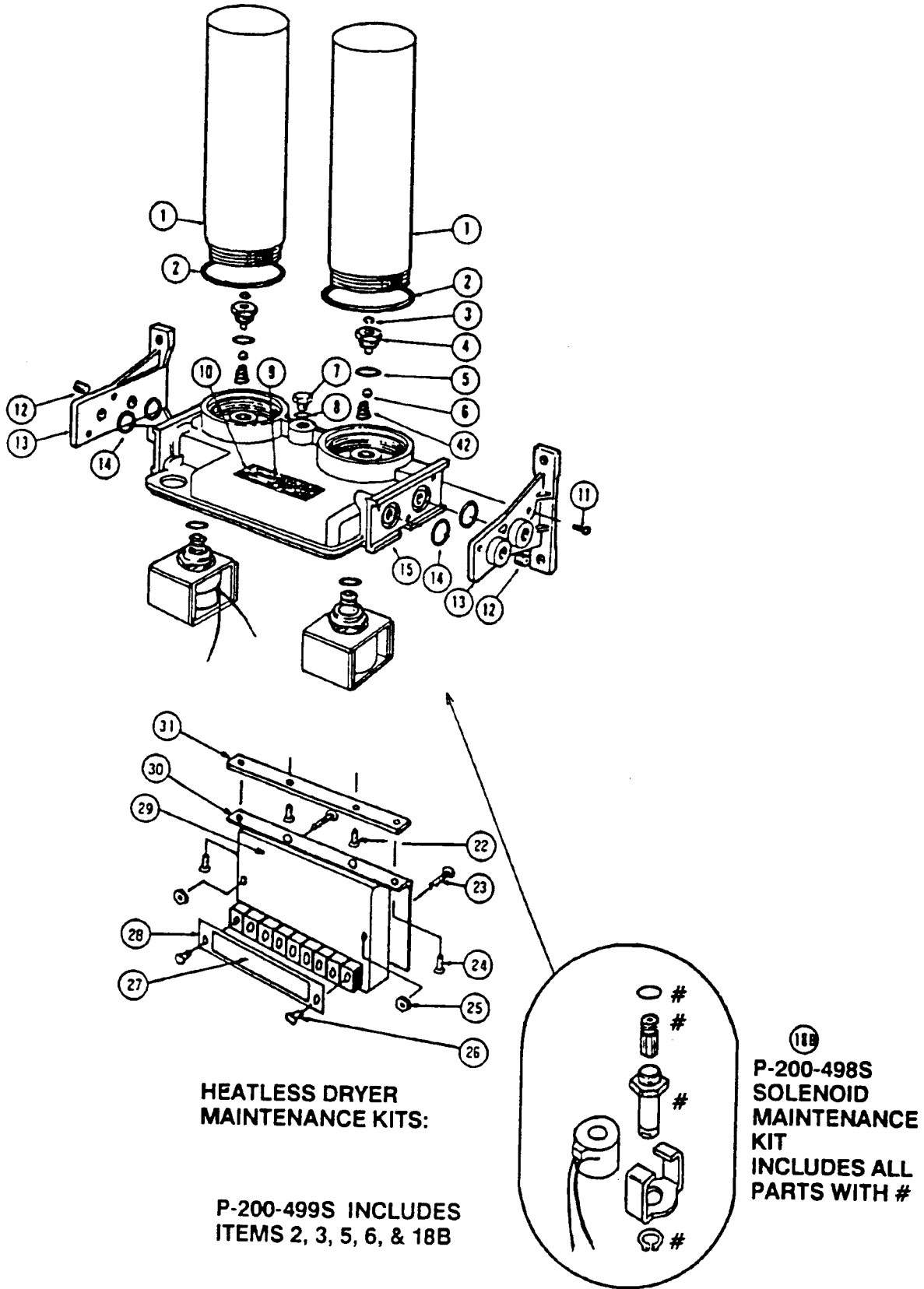

**EXPLODED VIEW OF HEATLESS DRYER (SOLID STATE TIMER MODEL)**  
Figure 12



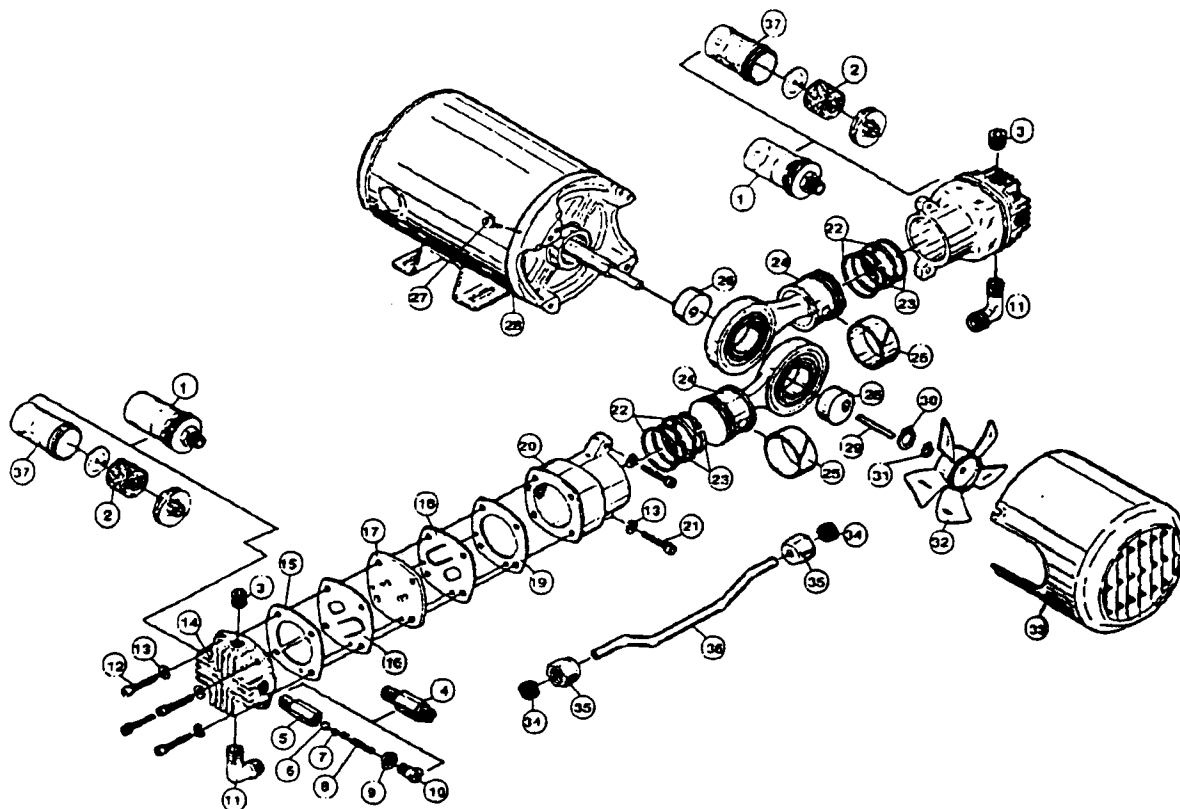

**EXPLODED VIEW OF AIR COMPRESSOR AND MOTOR ASSEMBLY**  
**Figure 13**

<u>Ref. No.</u>	<u>Description</u>	<u>Qty.</u>	<u>Part No.</u>	<u>Ref. No.</u>	<u>Description</u>	<u>Qty.</u>	<u>Part No.</u>
1	Air Intake Filter Assy.	2	P-02619	20	Cylinder	2	P-3874
2	Felt	1	P-3986	21	Cylinder Screw	4	P-3979
3	Pipe Plug	2	P-3998	22	Piston Ring	4	P-3862
4	Safety Valve	1	P-3996	23	Piston Seal	4	P-3861
5	(Included in #4, above)	1	-	24	Piston Rod Assy.	2	P-3872
6	(Included in #4)	1	-	25	Rider Ring	2	P-3981
7	(Included in #4)	1	-	26	Eccentric	2	P-01238
8	(Included in #4)	1	-	27	Screw	4	P-4033
9	(Included in #4)	1	-	28	Bracket	1	P-01239
10	(Included in #4)	1	-	29	Square Key	1	P-4040
11	Manifold Elbow	2	P-4024	30	Ring, Not Supplied	1	-
12	Head Screw	8	P-4025	31	Retaining Ring	1	P-4041
13	Lock Washer	12	P-4026	32	Fan	1	P-3873
14	Cylinder Head	2	P-3875	33	Shroud	1	P-3871
15	Head Gasket	2	P-3866	34	Manifold Sleeve	2	P-3864
16	Valve Outlet	2	P-3867	35	Manifold Nut	2	P-4043
17	Valve Plate	2	P-3870	36	Manifold	1	P-01240
18	Valve Inlet	2	P-3868	37	Disc, Filter Hold Dn.	2	P-02618
19	Cylinder Gasket	2	P-3869				

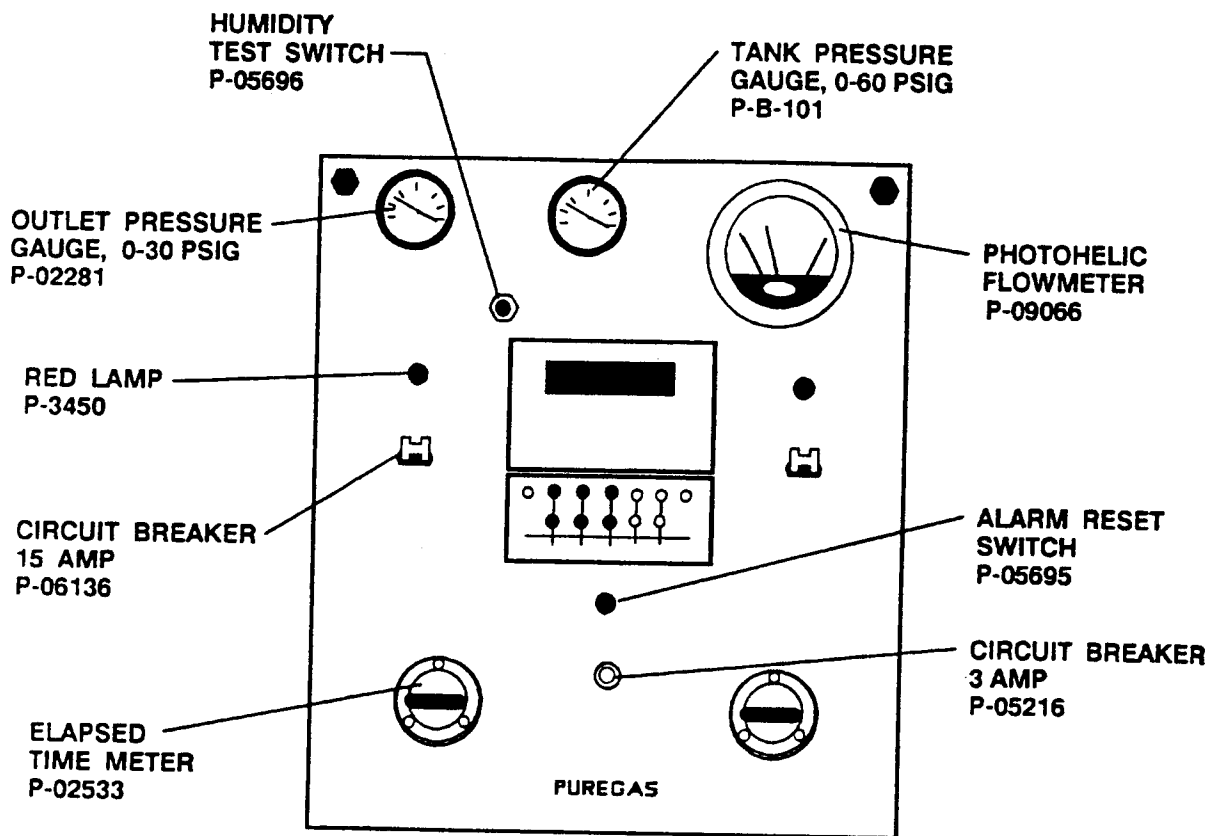

**FRONT CONTROL PANEL**  
Figure 14

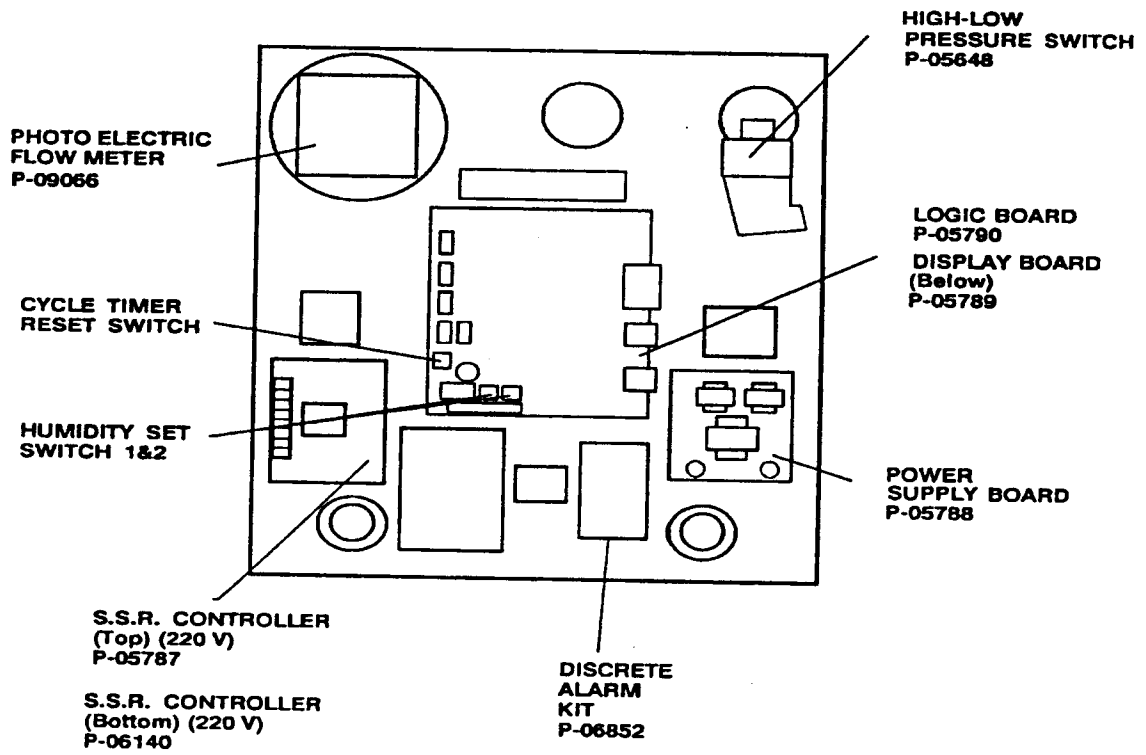

REVERSE SIDE OF CONTROL PANEL  
Figure 15

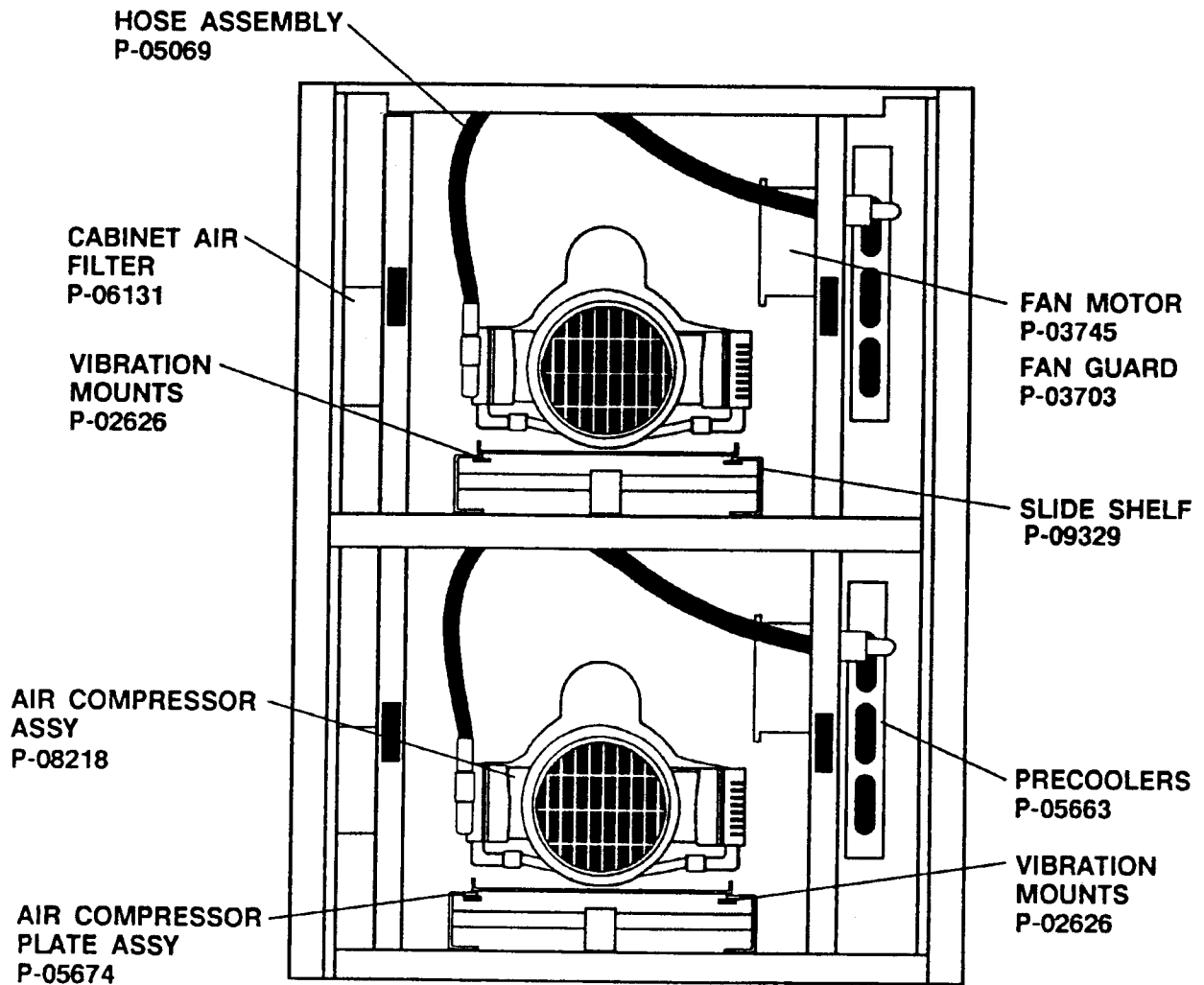

**AIR COMPRESSOR COMPARTMENT**  
Figure 16

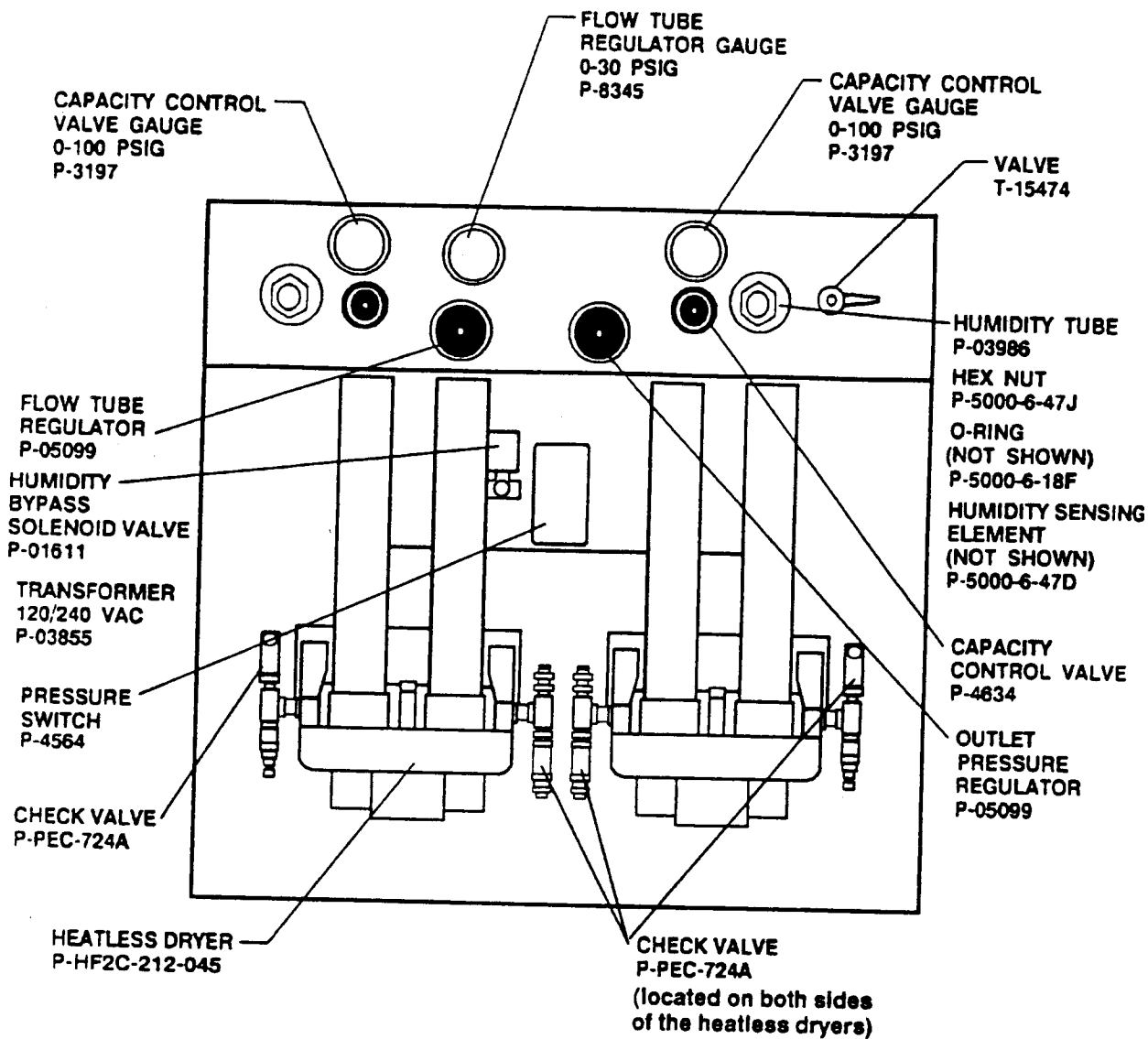

**HEATLESS DRYER - TOP CONTROL PANEL**  
**Figure 17**

EXCEPT AS MAY BE OTHERWISE PROVIDED BY CONTRACT, THESE DRAWINGS AND SPECIFICATIONS ARE THE PROPERTY OF MOBILE TOOL INTERNATIONAL. ARE ISSUED IN STRICT CONFIDENCE AND SHALL NOT BE REPRODUCED, COPIED OR USED AS THE BASIS FOR THE MANUFACTURE OR SALE OF APPARATUS WITHOUT PERMISSION.

REVISONS		DWG. NO. P05768		
REV	DESCRIPTION	BY	DATE	EOD
G	REVISED & REDRAWN	MAC	10/4/99	31303

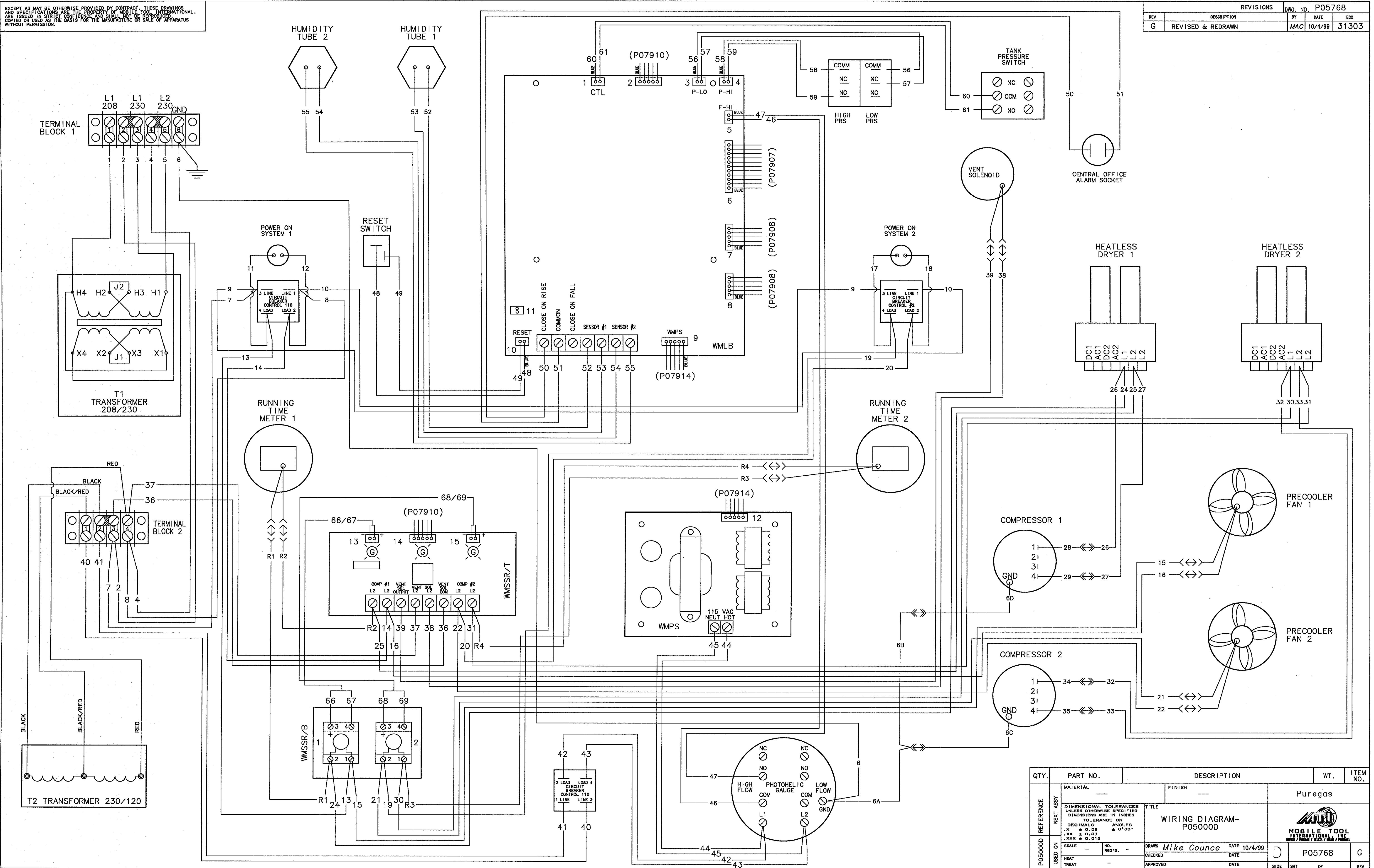

QTY.	PART NO.	DESCRIPTION	WT.	ITEM NO.
				Puregas
POS0000	REFERENCE	TITLE: WIRING DIAGRAM-P050000		
USED ON	SCALE	NO. REQ'D.	DATE	DATE
HEAT TREAT				
		APPROVED	DATE	DATE

MOBILE TOOL INTERNATIONAL, INC.	DATE: 10/4/99	BY: Mike Counce
MOBILE TOOL INTERNATIONAL, INC.	DATE:	BY:
MOBILE TOOL INTERNATIONAL, INC.	DATE:	BY:

## SECTION 7 TROUBLESHOOTING INFORMATION GUIDE

7.0 This troubleshooting guide is set in a columnar format to simplify the isolation of problems, possible causes, areas to check and corrective action required to restore the air dryer to normal operation. It is further divided into system headings for easy referral. Where possible, the most likely causes have been listed first. Otherwise, the causes start with the simplest and progress to more complicated possibilities. The steps should be followed in sequence to expedite service. It is further suggested that once the problem has been isolated, the corresponding text in the Maintenance Section be reviewed to provide additional information. After the air dryer has been serviced, the alarms should be re-tested to assure the alarm system is working properly.

The alarm troubleshooting guide is easy to use and very effective when used properly. Therefore, it is suggested when entering a problem, always start at the beginning and continue in sequence by reading the possible cause, check and corrective action paragraphs and follow the procedures indicated.

This guide will require a Volt Ohm Meter (VOM) and will specify D.C. (direct current) or A.C. (alternating current) setting.

The troubleshooting information guide can by no means cover every possible cause for malfunction, but will help solve most problems. If the problem persists after thoroughly consulting the troubleshooting section, contact General Cable Company, Puregas Technical Service Department at (303) 427-3700 or 1-800-521-5351.

### **DANGER**

**This section requires access to components inside the cabinet of the air dryer. In most cases, an energized and operating air dryer is necessary to conduct a test and make adjustments. Extreme care should be exercised to avoid contact with live electrical or moving parts.**

## SECTION 7

### TROUBLESHOOTING GUIDE

This troubleshooting guide is designed to assist in correcting most problems encountered, but can by no means cover all possible problems. Follow the guide in the order the steps are listed from easiest to most complex. After trying all suggested steps if the problem persists, contact PUREGAS Technical Service Department at 1-800-521-5351 for further assistance.

#### 7.1 Alarm Display Summaries

**Problem A: Hi Pres. appears at the alarm display.**

Refer to alarm summary, 3.12.1, Page 10 and alarm adjustment, Section 6.5, Page 25.

**Problem B: Low Pres. appears at the alarm display.**

Refer to alarm summary, 3.12.2, Page 10 and to alarm adjustment, Section 6.5, Page 25.

**Problem C: C.P. Sys. appears at the alarm display.**

Refer to alarm summary, 3.12.3, Page 10 and compressor performance alarm guide, Page 20.

**Problem D: -HC- appears at the alarm display.**

Refer to alarm summary, 3.12.5, Page 10, and to the humidity condition test procedure on Pages 14-16.

**Problem E: Humi.-1 or Humi.-2 appears at the alarm display.**

Refer to alarm summary, 3.12.6, Page 11 and to the humidity alarm guide on Pages 30 and 31.



## 7.2 Air System

### Problem A: Low Pressure Alarm

<u>Possible Cause:</u>	<u>Check:</u>	<u>Corrective Action:</u>
<b>A1.</b> Outlet pressure regulator is set too low.	Check the outlet pressure gauge. The factory alarm set point is 7 PSIG.	If setting is below 7 PSIG, adjust the setting for 7 PSIG.
<b>A2.</b> Leak in the air system.	With no outlet flow, check all fittings with an appropriate leak testing solution.	Tighten any loose connections and fittings as required.
<b>A3.</b> Defective outlet pressure gauge.	Using a B gauge, check the outlet pressure at the outlet pressure test valve.	The readings should be the same (+ 1) PSIG. If so, proceed to Step 7. If not, replace gauge.
<b>A4.</b> Weak air compressor	If no leaks, and compressor runs excessively long or C.P. Sys.1 or C.P. Sys.2 alarm.	Install routine maintenance kit.
<b>A5.</b> Pressure alarm out of adjustment or defective.	Check the low outlet pressure alarm setting as described in Section 5.1.	Readjust the pressure switch or replace if defective.
<b>A6.</b> High ambient temperature.	Check the ambient temperature.	If above 120 <sup>o</sup> F., cool area around air dryer or relocate air dryer to a cooler environment.
<b>A7.</b> Defective pressure switch.	Disconnect wire 57 from the switch.	If alarm clears, replace pressure switch. If alarm remains, replace logic board.

7.2 Air System (continued)

**Problem B: High Pressure Alarm**

<u>Possible Cause:</u>	<u>Check:</u>	<u>Corrective Action:</u>
<b>B1.</b> Outlet pressure regulator is set incorrectly or is defective.	Check the setting of the outlet pressure regulator.	Readjust if set incorrectly or replace if defective.
<b>B2.</b> Pressure alarm out of adjustment.	Check the high outlet pressure alarm setting as described in Section 5.2.	Readjust the pressure switch or replace if defective.
<b>B3.</b> Defective outlet pressure gauge.	Using a B gauge, check the outlet pressure at the outlet pressure test valve.	The readings should be the same <u>+1</u> PSIG. If so, proceed to Step 5. If not, replace pressure gauge.
<b>B4.</b> Obstruction in the delivered air.	Check pressure lines in dryer for debris.	Clean out lines and connections of any debris.
<b>B5.</b> Defective pressure	Disconnect wire 58 from the switch.	If alarm clears, replace pressure switch. If alarm remains, replace logic board.

7.2 Air System (continued)

**Problem C: Compressor performance alarm cannot be reset.**

<u>Possible Cause:</u>	<u>Check:</u>	<u>Corrective Action:</u>
C1. The air compressor is running.	Listen for compressor running.	Wait until the air compressor shuts off and reset the switch.
C2. Defective alarm reset switch.	With power off, use a volt-ohm meter to verify the switch opens when toggled.	If switch does not open when toggled, it must be replaced.

**Problem D: Compressor will not build pressure.**

D1. Compressor requires maintenance	Check rings and valves for excessive wear.	Install maintenance kit.
D2. Capacity control valve is defective or requires adjustment	Check capacity control valve for proper adjustment	Adjust to 50 ( $\pm 2$ ) PSI.

### 7.3 Humidity Alarm System

#### Problem A: Air Dryer in Humidity Alarm

<u>Possible Cause:</u>	<u>Check:</u>	<u>Corrective Action:</u>
A1. Humidity circuit out of adjustment or defective.	Check the humidity alarm set point.	Disconnect sensing cord. If the humidity alarm clears, the humidity indicator is correct and the air dryer can be assumed to be "wet". If the alarm does not clear, the problem is in the humidity circuit. Proceed to next step.
A2. Loose or poor electrical connections.	Check all wiring in the humidity circuit for good and proper connections.	Repair any bad connections.
A3. Humidity circuit out of adjustment.	Check for proper adjustment	Readjust the humidity circuit as outlined in Section 6.14. If circuit board fails to adjust, replace logic board.
A4. Low system pressure.	Check the capacity control valve setting. It should be at 48 PSIG.	Adjust capacity control valve to 48 PSIG as described in Sections 6.6.
A5. Leaking humidity test switch.	Check humidity test switch for leakage into humidity tube.	Replace humidity test switch if defective.
A6. Defective timer in dehydrator.	Refer to Section 6.14.6 for proper timer operation.	Replace timer if it is defective.
A7. Excessively high ambient temperature.	Check ambient temperature. It should be below 90° F.	Cool environment around dryer or relocate dryer to cooler environment.
A8. Dryer is flowing very little air.	The flowmeter will indicate the present amount of flow. It should be at least 2000 SCFD.	If flow is below 2000 SCFD, create an artificial leak to obtain 2000 SCFD.

### 7.3 Humidity Alarm System (continued)

#### Problem B: Air Dryer Humidity Alarm doesn't function

Note:

*The following are possible causes for a humidity condition. After isolating and correcting the problem, the air dryer may have to be run up to 5 minutes to dry out the entire system and clear the alarm. The higher the system pressure, the faster the towers will dry out. It is advisable to run the dehydrator at 48-50 PSIG to dry out the towers.*

**CAUTION:  
DO NOT MEASURE SENSING ELEMENT OR IN ANY  
WAY APPLY DC VOLTAGE TO THE SENSING ELEMENT**

<u>Possible Cause:</u>	<u>Check:</u>	<u>Corrective Action:</u>
B1. Defective humidity sensing element.	Toggle the humidity switch or the humidity set switch.	If the dryer does not go into a humidity condition and hold that condition, replace the sensing element.
B2. Loose or poor electrical connections.	Check wires 52, 53, 54, and 55 for good connections. Wires 52 and 53 should be connected to sensor #1. Wires 54 and 55 should be connected to sensor #2.	If wires are located incorrectly, make the appropriate changes.

## 7.4 Electrical System

### Problem A: No power to the air dryer

<u>Possible Cause:</u>	<u>Check:</u>	<u>Corrective Action:</u>
A1. Power has been interrupted to the dryer.	Check the main power supply or fuse panel.	Reset the main power supply or replace the bad fuse.
A2. A faulty electrical connection in the T2 transformer.	Disconnect incoming power. Inspect electrical connections in the transformer.	Provide new connections as necessary. Reinstate power to unit. Use volt-Ohm meter and wiring diagram to verify proper output voltage.
A3. Circuit breaker tripped at main power supply.	Check circuit breaker to see if it has tripped. Check for 110 VAC at power connections.	Reset 3 amp circuit breaker. Check power supply for sufficient voltage.
A4. Loose or poor electrical connections.	Check power connections.	Repair any bad electrical connections.

### Problem B: No power to the air compressor, but other components have power.

B1. Loose or poor electrical connections.	Check for 230 volts AC to the air compressor.	Repair any bad electrical connections.
---	---	--

### Problem C: Power to dryer, but the air compressor does not operate.

C1. Humidity alarm after set time delay.	Check for humidity alarm on display.	If dryer is in a humidity alarm, refer to Section 6.14, Pages 30 and 31.
C2. Loose or poor electrical connections.	Check power connections at terminal block.	Repair any bad electrical connections.
C3. Check 15 amp circuit breaker.	With the breaker on, check for 230 volts AC at supply side and load side of the circuit breaker.	If voltage fails to be on both sides, replace breaker.
C4. Tank pressure switch.	This switch operates on 5VDC. When the contacts are closed, the compressors will operate.	Change sides of the switch or clean contacts. Apply contact grease.

## 7.5 Dehydrator

### Problem A: Heatless dryer delivers wet air

<u>Possible Cause:</u>	<u>Check:</u>	<u>Corrective Action:</u>
A1. Defective solenoid valve.	Check core assembly for broken spring and proper seating.	Defective parts should be replaced (core assembly or worn parts).
A2. Purge orifice plugged.	Check orifice for residue.	Clean orifice with air pressure. Do not use wire or anything abrasive. This will damage orifice.
A3. Solenoid coil burned out.	Check magnetic pull of coil with screwdriver. (Refer to next step before replacing coil.) Note: Each coil should be energized every 30 seconds.	Replace if necessary.
A4. Improper operation of cycle timer.		Locate power loss.
A5. Improper operation of cycle timer.	Check for 220 VAC on screws L1 and L2. Tighten connections, if needed.	If no operation with voltage applied, replace timer.

7.3 Dehydrator (continued)

**Problem B: A white powder is in the cable or exhaust**

<u>Possible Cause:</u>	<u>Check:</u>	<u>Corrective Action:</u>
<b>B1.</b> Deteriorated desiccant towers	Check movement of perforated disc at open end of chambers (disc should not depress more than 1/4" from retaining ring).	Replace chamber or have repacked. (Puregas recommends tower be repacked at the factory.)

**Problem C: Heatless dryer has excessive drop in outlet pressure.**

<b>C1.</b> Improper operating conditions.	See Heatless Dryer Characteristics, Section 3.3, Page 4.	Install the maintenance Kit.
<b>C2.</b> Solenoid coil burned out.	Check to see if every 30 seconds exhaust air will purge from the bottom of one side or the other.	If one side fails to purge, replace solenoid valve.
<b>C3.</b> Improper operation of cycle timer. (Solid State)	Check to see if every 30 seconds the timer switches sides of operation.	If proper voltage is applied and this switching does not occur, replace the timer.
<b>C4.</b> Check to see if valve balls are seated properly.	Check rings and valves for excessive wear.	Replace if necessary



## Optional Equipment

### Filter/Automatic Drain (P-07329 - 2-required)

The function of the inlet filter/drain assembly is to collect and remove liquid condensate and particles larger than 5.0 u.M., contained in the compressed inlet air.

P-07765 (Replacement element for above option).

P. O. Box 666, 5600 West 88th Avenue, Westminster, Colorado 80030 (303) 427-3700

**INSTALLATION INSTRUCTIONS FOR  
WHISPER DISCRETE ALARM KIT P-05839**

1. To mount this kit, a drill with a 3/16" bit is required.
2. Open the top front panel. There is enough room to mount the board to the right of the system #1 hour meter and to the left of the on/off switch.
3. Using the spacers and screws in the kit, mount the board.
4. Plug in the cable to the vacant 12 pin connector on the control board (left side).
5. Use the following *Diagrams A and B* to link up to your monitoring system.

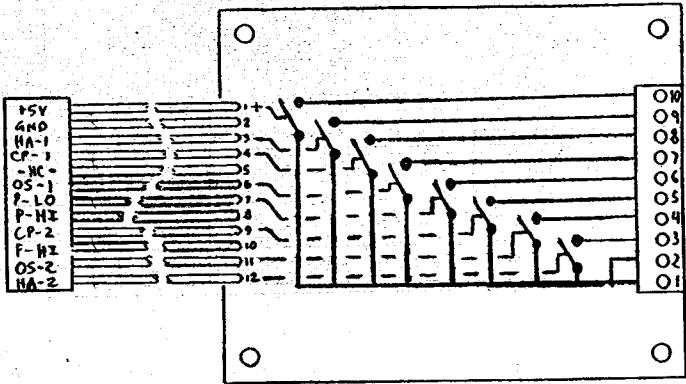

**Diagram A**

These alarms are the standard configuration. If you would like to substitute OS-1 and OS-2 for P-HI and F-HI, use *Diagram B*.

PWR FAIL	PINS 1 & 10
HA-1	PINS 1 & 9
CP-1	PINS 1 & 8
OS-1	PINS 1 & 7
P-LO	PINS 2 & 6
CP-2	PINS 2 & 5
OS-2	PINS 2 & 4
HA-2	PINS 2 & 3

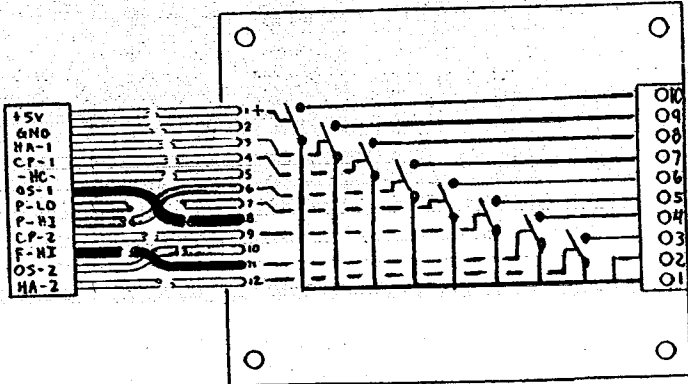

**Diagram B**

To switch OS-1 and OS-2 to P-HI and F-HI, remove wires from pin 6, 8, 10 and 11 of the white connector. Use a small pointed screwdriver to push the metal pin out of the connector. Re-arrange the connections as shown by crossing 6 and 8 as well as 10 and 11.

PWR FAIL	PINS 1 & 10
HA-1	PINS 1 & 9
CP-1	PINS 1 & 8
P-HI	PINS 1 & 7
P-LO	PINS 2 & 6
CP-2	PINS 2 & 5
F-HI	PINS 2 & 4
HA-2	PINS 2 & 3

P-06848