



Owners Manual UA & MHT Series Refrigerated Air Dryer



DESCRIPTION	PAGE
INTRODUCTION	2
RECEIVING & INSPECTION	
INSTALLATION	3
INSTALLATION GUIDE	4
DRYER CONTROLS & SAFETY SHUTDOWNS	5-6
START UP	
INITIAL RUN PROCEDURE	7
MAINTENANCE PROCEDURES	8
HOW THE AIR DRYER WORKS	
DESCRIPTION OF COMPONENTS	9
TROUBLE SHOOTING GUIDE	10
TECHNICAL SPECIFICATION	11-14
DATA LABEL—UA SERIES	15
DATA LABEL—MHT SERIES	16
ELECTRICAL SCHEMATICS	17-22
SERVIVE LOG	23
CONTACT INFO	24

IMPORTANT: READ THIS MANUAL CAREFULLY. IT CONTAINS INFORMATION ABOUT SAFETY AND THE SAFETY OF OTHERS. ALSO BECOME FAMILAR WITH THE PROPER INSTALLATION AND CONTROLS OF THE AIR DRYER BEFORE OPERATING. ONLY QUALIFIED, TRAINED AND LISCENSED PERSONAL SHOULD SERVICE OR OPERATE THIS EQUIPMENT. RECORD THE INFORMATION BELOW AND SAVE THIS MANUAL. IF SERVICE IS NEEDED THE INFORMATION BELOW WILL BE NEEDED.

CAUTION: THIS MACHINE CONTAINS HIGH PRESSURE GAS AND ELECTRICITY.

NOTE: Please record the information below and keep this manual. If you need service on this dryer you will need this information.

Use [QR Code](#) to register your new Atec AIR Refrigerated Air Dryer

Model # _____
 Serial # _____
 Voltage _____

Purchased from: _____



INTRODUCTION

Thank you for selecting an UA/MHT Series refrigerated air dryer from Altec AIR.

The refrigerated air dryer is specifically designed and manufactured for drying and purifying compressed air generated by an air compressor.

Please read this instruction manual carefully before using the air dryer and pay attention to the precautions in transportation, installation and operation that are listed in this manual.

Please use the dryer according to our application guide and be sure to perform the proper preventative maintenance as recommended in this manual. Failure to perform the preventative maintenance will void the air dryer warranty.

Refrigeration used in this air dryer is environmentally friendly R134a or R404a and is available at local refrigeration wholesalers.

Direct any questions not covered in this manual to your distributor or call Altec AIR @ 1-800-521-5351. Before calling with questions always have the air dryer model #, serial # and pressure gauge readings.

Service and maintenance can be obtained from your distributor. If you do not know your distributor please contact the factory. Authorization must be obtained from Altec AIR before any parts or dryers are returned to the factory. Altec AIR will not be responsible for anything returned without authorization.

RECEIVING AND INSPECTION

The dryer cannot be tilted on its side or upside down during shipping.

Use forklift from the bottom of the dryer when installing or moving.

- Dryers are shipped F.O.B. factory. Immediately upon arrival check the dryer for possible damage. If damage is found, report it to the carrier and file a damage claim. Check dryer data label to be sure you have the right dryer. Check the data labels voltage and amperage to be sure it is correct and the one you ordered. Check the refrigeration gauges for pressure.

If the gauges read 0 PSIG, STOP.

- Do not start the dryer. Contact Altec AIR or your local distributor for service. This could mean there is a leak in the refrigeration system.

Data Label

- The data label is affixed to the outside of the cabinet.
- This label identifies the air dryer's model and serial numbers and important technical data.
- Before installing the dryer check all of the information on the data label for the correct model and voltage.

If the model number and voltage are incorrect do not install or power ON the dryer.

Contact Altec AIR or your local distributor immediately.

DATA LABEL	
Model	UA200A-2
Serial #	
Date of MFG.	1/8/2016
Voltage	230v-1ph-60hz
Voltage Range	253-187
RLA	7
LRA	41
Min Circuit Ampacity	9.9
Max Fuse Size	15
Maximum Inlet Air Temp - F	110
Min/Max. Ambient Temp - F	110/45
Ref. System Design - PSI	350/150
Suction/Discharge - PSI	30/120
Maximum Pressure (PSIG)	232
Ref. Compressor HP	1
Refrigerant Type	R134A
Refrigerant Charge	CF
MADE IN USA	
DISCONNECT POWER SUPPLY BEFORE SERVICING	

INSTALLATION

DRYER LOCATION / VENTILATION

Install dryer only in a well-ventilated, clean, dry area and keep at least 3 feet between the dryer, other equipment and the walls. Dust and dirt particles will clog the air-cooled condenser and will reduce the performance of the dryer and will eventually cause damage to it.

Do not install the dryer outside. The air dryer must not be exposed to direct sunlight, rain or snow.

AMBIENT TEMPERATURES

Suitable ambient temperature for the refrigerant dryer is a MIN of 45°F to a Max of 110°F. The performance of the dryer will be significantly decreased when the air dryer is subject to temperatures higher than 110°F.

For installations with ambient temperatures higher than 110°F it is recommended to use a water-cooled condenser on the dryer. Contact Altec AIR or your local distributor for details

INLET & OUTLET CONNECTIONS

Do not mix the air inlet and outlet air flow. Pipe diameter should be sized according to air flow requirements. It is recommended that a vibration absorber be installed on the dryer inlet and outlet to eliminate vibration from the compressor. Do not use the inlet and outlet of the air dryer to support the weight of the air piping.

FILTRATION, BYPASS VALVES, & CONDENSATE DRAINS

Appropriate pre and post filtration should be installed to protect the air dryer as well as the compressed air system.

Isolation or 3-valve bypass should be installed on the air dryer outlet and inlet ports to allow for bypassing, depressurizing, proper maintenance, and servicing of the air dryer.

Condensate drains must be properly piped from the dryer to prevent moisture re-entrainment. The dryer is equipped with an automatic drain valve that controls the discharge of the condensate. The user must run a drain line to an environmentally approved condensate collection/disposal system.

ELECTRICAL INSTALLATION

The dryer Data Label lists the electrical power requirements for the air dryer. The user must confirm that the line voltage matches the voltage listed on the data label. (Warning – Operating the air dryer with improper line voltage will void the warranty). Provide the proper size wire, disconnect switches and fuses in accordance with applicable codes. Field wiring must comply with local and national fire safety and electrical codes. Standard dryer's enclosures and controls are designed to meet NEMA 1 Type 1 electrical standards.

Connect power leads as indicated in the electrical schematic. Ground the frame properly.

IMPORTANT NOTE: UA/MHT series dryer refrigeration compressors must be wired for proper rotation with the proper phases L1, L2, L3. To check if dryer is wired properly turn dryer on and observe the REFRIGERANT SUCTION PRESSURE GAUGE, immediately after the dryer is switched ON the pressure on this gauge should drop. If after 30-45 seconds the pressure does not drop switch the dryer OFF. This could mean the dryer is wired wrong. Switch any 2 leads and repeat.

MAXIMUM WORKING PRESSURE - 232 psig.

BREATHING AIR APPLICATIONS

This dryer has not been tested for breathing air applications. The owner is advised to do its own testing and use for breathing air applications at owns risk.

INSTALLATION GUIDE

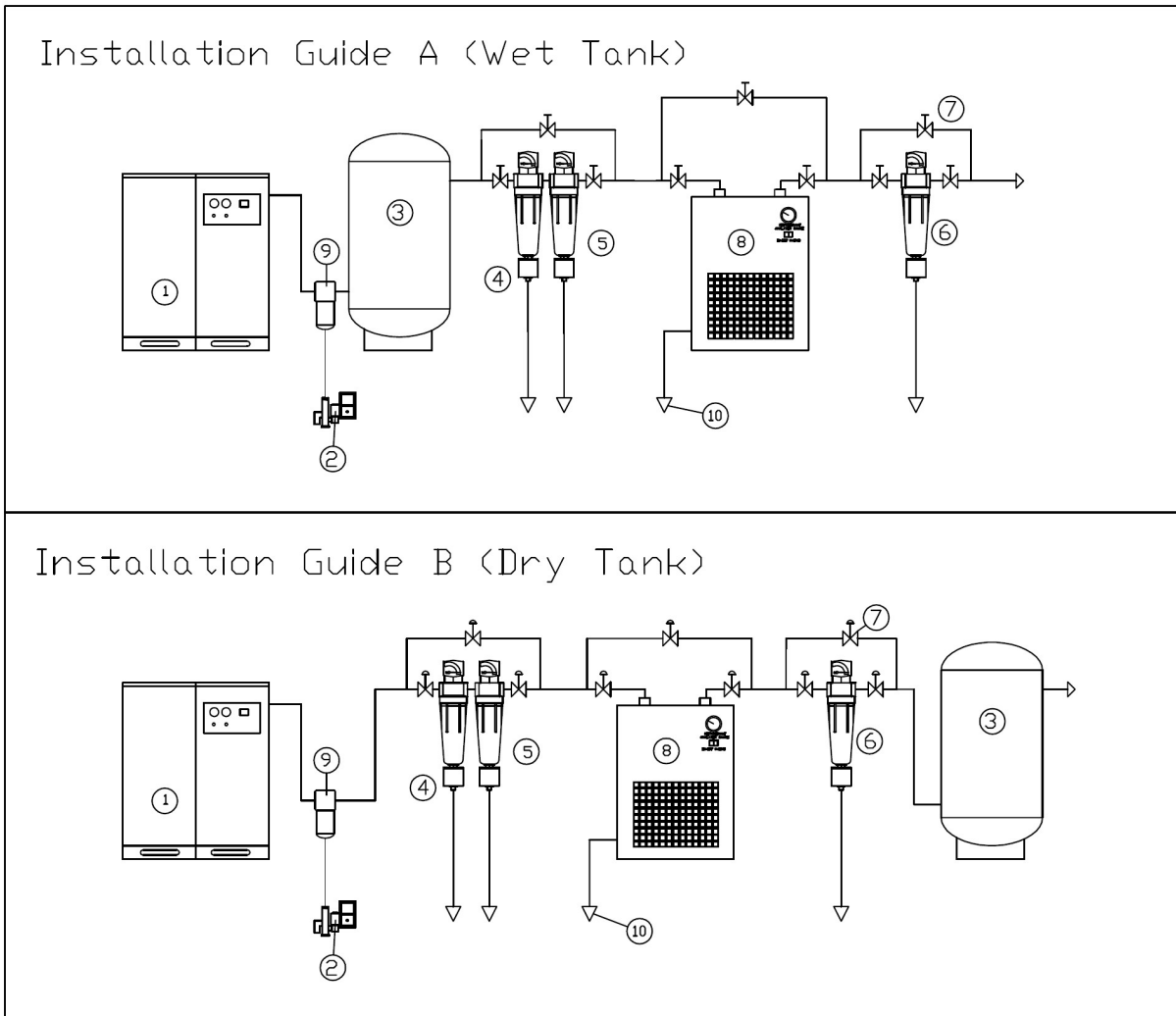

- | | |
|-----------------------------|---|
| (1) Air Compressor | (6) AC Series XA After filter |
| (2) ADF Series Drain Valve | (7) 3 Valve Bypass |
| (3) Air Receiver Tank | (8) UA/MHT Series non-cycling air dryer |
| (4) AC Series X5 Pre-filter | (9) AW Series Water Separator |
| (5) AC Series X1 Pre-filter | (10) Centrifugal separator |

INSTALLATION A: Recommended for systems that consume less than or equal to the maximum capacity of the air compressor.

INSTALLATION B: Recommended for systems that consume more than the maximum capacity of the air compressor.

DRYER CONTROLS

1. ON/OFF Switch – Turns the refrigerant compressor and dryer ON.
2. Dryer ON Light – Indicates the air dryer is turned on and operating. Integrated into ON/OFF Switch
3. Refrigerant Suction Pressure Gauge - Displays refrigeration system low side (Evaporator) pressure. (Installed on UA75/MHT40 and above)
4. Refrigerant Discharge Pressure Gauge - Displays refrigeration system high side pressure. (Installed on UA400/MHT200 and above)
5. Inlet Compressed Air Temperature Gauge - Displays air temperature for the compressed air source (Installed on UA1600 and above)
6. Dewpoint Temperature Gauge - Displays outlet dewpoint to ensure dryer is performing correctly. (Installed on UA20 to UA55, and MHT25)
7. Hot Gas Bypass Valve (HGBV) – Prevents compressed air freeze ups by controlling the evaporator pressure.
8. Temperature Expansion Valve (TXV) - Metering device between the liquid refrigerant line to the evaporator. (Installed on UA400/MHT200 and above)
9. High Pressure Shutdown w/manual reset - Shuts down dryer in the event of overload conditions (Installed on UA150/MHT100 and above)
10. Low Pressure Shutdown - Shuts down the dryer in the event of low ambient temps or if there is a refrigerant leak in the system. (Installed on UA200A-3/MHT130A-3 & UA250-2/MHT150A-2 and above)
11. Fan Cycling Switch(s) - Cycles condenser fan(s) ON and OFF during periods of low ambient temperatures. (Installed on UA400 and above).
12. Programmable Electronic Auto-Drain Valve – Automatically controls the draining of liquid condensate removed by the dryer.
13. Compressor Internal Overload. - Shuts down the refrigerant compressor if amp draw/heat is to high.
14. Control Fuses - Shuts down the dryer in the event of high amp draw on the control circuit.

Dryer Model	Refrigerant	Normal SUCTION PSIG	Normal DISCHARGE PSIG	Dew point Temp
UA20 to UA150	R134A	25 to 35 PSIG	75-120 PSIG	33 to 39 F
MHT25 to MHT100	R134A	25 to 35 PSIG	75-120 PSIG	33 to 39 F
UA200 to UA2000	R404A	69 to 85 PSIG	135 to 275 PSIG	33 to 39 F
MHT130 to MHT200	R404A	69 to 85 PSIG	135 to 275 PSIG	33 to 39 F

DANGER

Only qualified and licensed refrigeration service persons should attempt to work on the air dryer.

DRYER CONTROLS AND SAFETY SHUTDOWNS

HOW TO MAKE MINOR REFRIGERANT SUCTION PRESSURE ADJUSTMENTS.

Keep dryer running under a no load by turning OFF or bypassing the compressed air.

Remove dryer top and locate the Hot Gas Bypass Valve. Remove cap on Hot Gas Bypass Valve and turn valve counter clockwise to decrease the suction pressure and clockwise to increase the suction pressure.

Make ½ turn adjustments and wait 2 to 3 minutes for suction pressure to stabilize. Make more adjustments if needed.



HIGH PRESSURE SHUTDOWNS WITH MANUAL RESET

Shuts the dryer down in the event of a dirty condenser, fan motor failure or excessively high ambient temperatures (Installed on UA150/MHT100 and above)

LOW PRESSURE SHUTDOWN

Shuts the dryer down in the event of low ambient conditions or if there is a leak in the refrigeration system. (Installed on UA400/MHT200 and above)



START UP

The following procedure must be followed to start your air dryer. Failure to follow this start up procedure will void your warranty. If problems occur during start up, contact Altec AIR or your local distributor.

1. Turn the ON/OFF switch to the OFF position.
2. Verify the main electrical supply voltage matches the voltage specified on the data label.
3. Check the proper connection and support of the compressed air lines to the dryer: check dryer bypass and isolation valve system.
4. Confirm that the inlet and ambient air temperature, pressure and flow to the dryer meet the specified requirements.
5. Confirm that the condensate drain lines from the separator are properly piped to an environmentally approved disposal system

INITIAL RUN PROCEDURE

After start up and checks are complete and after the main electrical power to the dryer has been connected, follow the procedure below to put the dryer in operation:

1. Turn ON the dryer ON/OFF switch.
2. Let the dryer run for 15 minutes.
IMPORTANT NOTE: All 230/460/575 VAC, 3 Phase motors MUST be wired for proper rotation. After the air dryer is turned ON, the suction pressure should DECREASE (pull down) instantly. If the suction pressure does not pull down TURN OFF THE AIR DRYER IMMEDIATELY and contact your local distributor or Altec AIR for assistance
3. Check the Refrigerant Suction Pressure (on Gauge UA75/MHT40 and above):
R134a dryers. (28 psig to 34 psig)
R404a dryers. (72 psig to 80 psig)
4. Check the Refrigerant Discharge Pressure (on Gauge UA400/MHT200 and above):
R134a dryers. (90 psig to 150 psig)
R404a dryers. (220 psig to 350 psig)
5. Verify that the condenser fan motors are operating. On units UA400/MHT200 and above fan will cycle ON and OFF as follows:
FAN 1 R404a dryers. (ON at 230 PSIG, OFF at 135 PSIG)
FAN 2 R404a dryers. (ON at 275 PSIG, OFF at 195 PSIG)
5. Allow compressed air to flow through the dryer.
6. Confirm that condensate is discharging from the condensate drain. This may take 30-60 minutes.
7. Make sure bypass valves are closed and 100% of the air from the compressor is flowing through the dryer.

HOW TO SET THE CONDENSATE DRAIN OPEN & CLOSED TIME (LOCATE DRAIN VALVE)

The OPEN (ON) time is adjustable from 0.5 sec to 10 sec. Drains are set at factory to open for 6 sec. When drain opens the on light will light

The CLOSED (OFF) time is adjustable 0.5 min to 45 min. Drains are set at factory to stay closed for 10 min. When drain is closed the off light will light.

You may increase or decrease this based on moisture levels in the air.

Push the TEST button to manually open the drain valve.



TO CLEAN VALVE

1. Close isolation valve
2. Push the push to test button to release the pressure
3. Remove strainer/filter and screen.
4. Clean screen and replace.

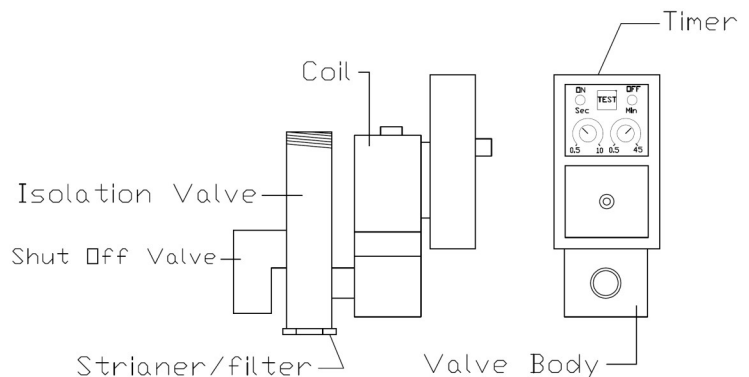

DESCRIPTION OF COMPONENTS - UA/MHT SERIES

- (1) **HEAT EXCHANGER MODULE** - The compact aluminum module contains the air to air heat exchanger, the air to refrigerant heat exchanger and the stainless steel mesh condensate separator.
- (2) **REFRIGERANT COMPRESSOR** – The main function of the compressor is to circulate the refrigerant. The compressor pumps refrigerant to the other components in the system so they can perform heat transfer functions. The compressor also separates the high pressure from the low pressure side of the refrigeration system.
- (3) **AIR-COOLED CONDENSER** – One of the main functions of the condenser is to condense the high pressure and high temp refrigerant vapor to liquid. A heavy duty fan moves ambient air across the condenser coils removing heat from the refrigerant vapor. As the heat is removed the refrigerant vapor the temperature change causes the refrigerant to change state from a vapor to a liquid. The condenser is made from aluminum fins attached to copper tubes.
- (4) **FLTER-DRIER** – Adsorbs and filters out any moisture or debris that maybe in the refrigeration system. Moisture can cause freeze ups and dirt particles can plug capillary tubes causing system malfunctions.
- (5) **TEMPERATURE EXPANSION VALVE (TXV)** – The metering device meters liquid refrigerant from the liquid line to the evaporator. Separates the high pressure side from the low pressure side in the refrigeration system. Installed on UA400/MHT200 and above. Capillary Tube Unit installed on UA300/MHT150 and below.
- (6) **HOT GAS BYPASS VALVE (HGBV)**– The HGBV responds to changes in suction pressure. As the compressed air flow (Or heat load) on the dryer changes the suction pressure will change. An increase in air flow causes an increase in suction pressure a decrease in air flow causes a decrease in suction pressure. During periods of low air flow the HGBV meters hot gas from the hot gas line of the high side to the inlet of the heat exchanger.
- (7) **LP1 - LOW PRESSURE SAFETY CUT OUT** – Prevents damage to the refrigerant compressor in the event of a refrigerant leak or low refrigerant pressure. Installed on UA200A-3/MHT130A-3 & UA250-2/MHT150A-2 and above
- (8) **PS1—HIGH PRESSURE SAFETY SHUTDOWN w/MANUAL RESET** - Prevents damage to the refrigerant compressor and other components in the event of high refrigerant pressure due to fan motor failure, dirty condenser or over capacity. Installed on UA150/MHT100 and above.
- (9) **FS1 FAN CYCLING SWITCH** – Cycles the condenser fan motor on and off to maintain the proper condensing pressure dryer periods of fluctuating loads and ambient conditions. Installed on UA400/MHT200 and above.
- (10) **FS2 FAN CYCLING SWITCH** – Cycles the condenser fan motor on and off to maintain the proper condensing pressure dryer periods of fluctuating loads and ambient conditions. Installed on UA400/MHT200 and above.
- (11) **SUCTION PRESSURE GAUGE** – Continuously monitors the refrigerant suction or low side pressure. Is used as a troubleshooting device. Installed on UA75/MHT40 and above.
- (12) **REFRIGERATION DISCHARGE PRESSURE GAUGE** - Continuously monitors the refrigerant discharge or high side pressure. Is used as a troubleshooting device. Installed on UA400/MHT200 and above.
- (13) **CONDENSER FAN MOTORS** – Drives ambient air over condenser coils.
- (14) **Y-STRAINER AND SHUTOFF VALVE**— Allows for easy service and cleaning of the drain valve
- (15) **PROGRAMMABLE AUTO CONDENSATE DRAIN**—Reliably drains away the moisture that was removed from the air by the dryer.

TROUBLE SHOOTING GUIDE

Problem	Cause	Solution
Excessive pressure loss in system	Bypass valve not completely open	Open completely
	Pipe diameter too small	Increase diameter
	Piping system has too many tie ins	Redesign pipe system
	Leaks in piping system	Fix leaks
	In line filter element clogged	Replace filter element.
Water downstream of dryer	Bypass valve not completely closed	Close bypass valve
	Air not going through dryer	Open inlet valve completely
	Under high flow conditions pressure drops significantly	Redesign compressed air source and check pipe diameter.
	Auto drain plugged or not working.	Clean drain or replace
	Dryer too small for inlet air flow	Replace dryer or reduce inlet flow.
	No pre filter in system	Install pre filter
Evaporator pressure is too high or too low.	Inlet air temp is too high	Check air compressor after cooler
	Air cooled condenser is clogged	Clean condenser
	Expansion valve is defective	Replace expansion valve
	Refrigerant leak	Find leak and fix. Add refrigerant
	Pressure gauge is bad	Replace with new gauge
	Hot gas bypass needs adjusting	Adjust valve to correct pressure.
Power is on to the dryer but the dryer will not start	Fuse is bad	Check for short, fix and replace fuse
	On/Off switch defective	Replace switch
	No power going to dryer	Check circuit breaker and power supply
	Power going to dryer is incorrect	Make sure power source and data label match.
	Contactors defective	Replace with a new one
	Over load relay defective	Replace with a new one
	Capacitor defective	Replace with a new one
	Start relay defective	Replace with a new one
	Pressure switch defective	Replace with a new one
	Temp switch defective	Replace with a new one
	Compressor defective	Replace with a new one
	High Pressure switch is open	Find reason and reset
	Low pressure switch is open	Find reason and reset
Thermostat open	Find reason and reset	
Evaporator Temp is too low	Hot gas bypass valve needs adjusting	Adjust or replace
	Evaporator pressure gauge bad	Replace
	Capillary tube blocked	Replace
	Temp or Pressure reset set too low	Reset
	Refrigerant leak	Find leak, fix it and add refrigerant
Evaporator Temp is too high	Ambient temp too high	Improve ventilation in area
	Hot Gas valve needs adjusting	Adjust or replace
	Condenser blocked or plugged	Clean condenser
	Flow is too high going in dryer	Change air compressor
	Compressor valves are damaged	Replace compressor

TECHNICAL SPECIFICATIONS

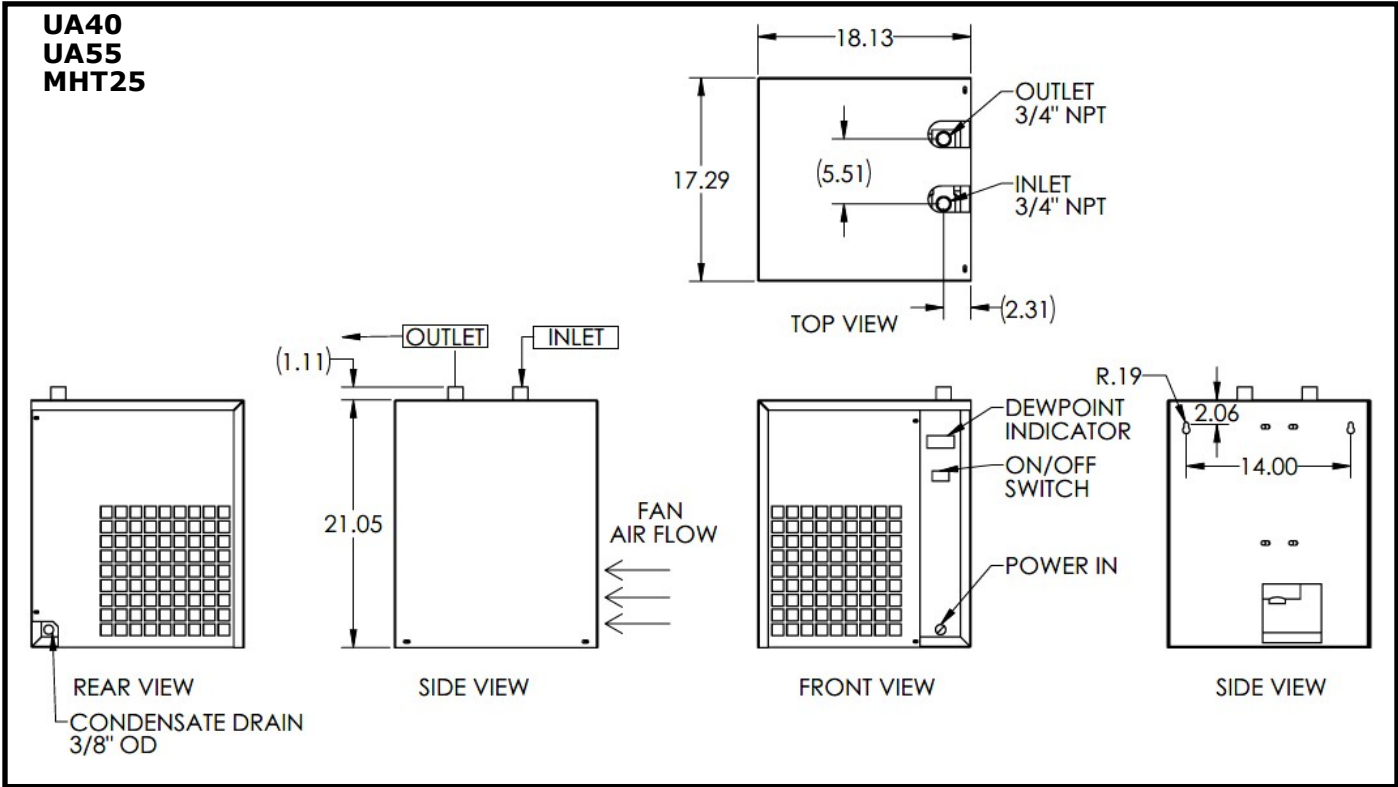
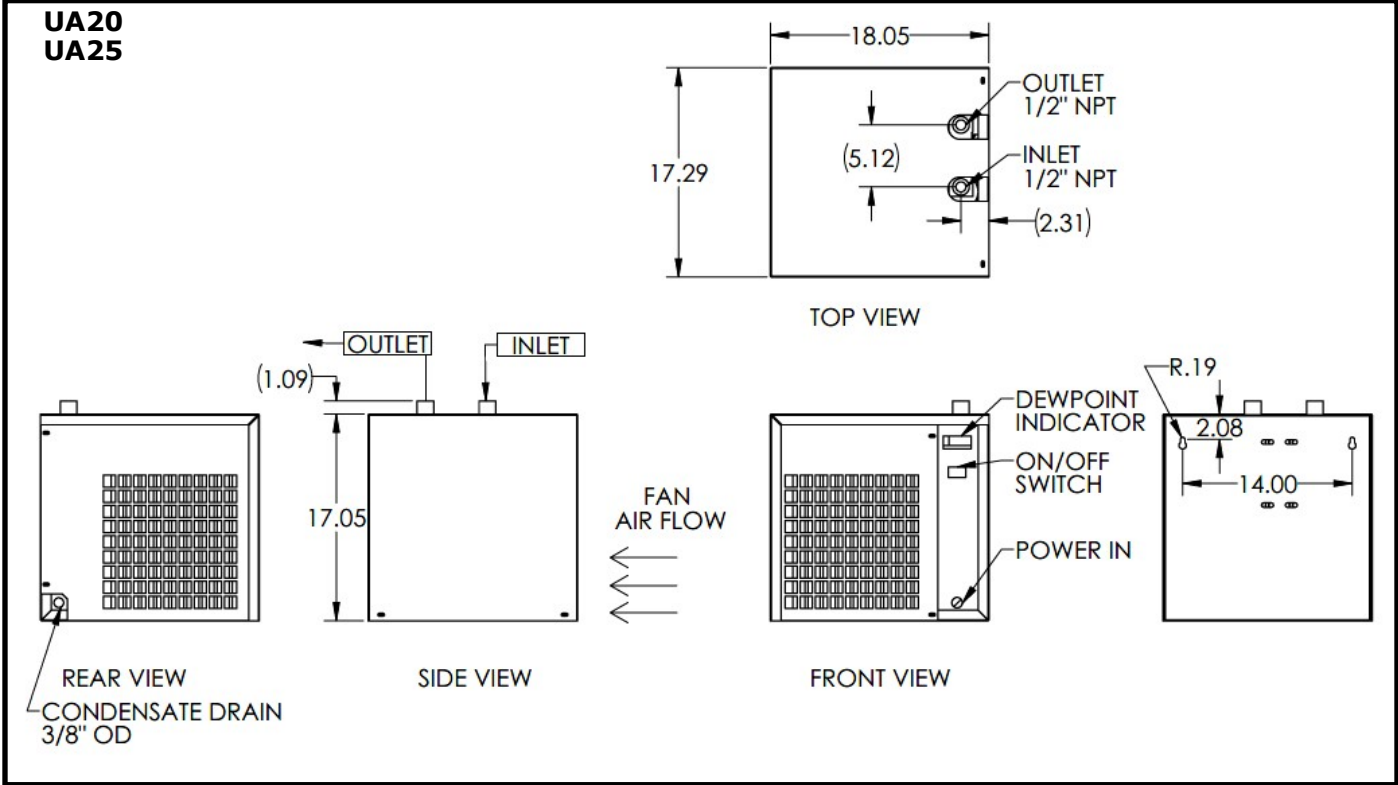

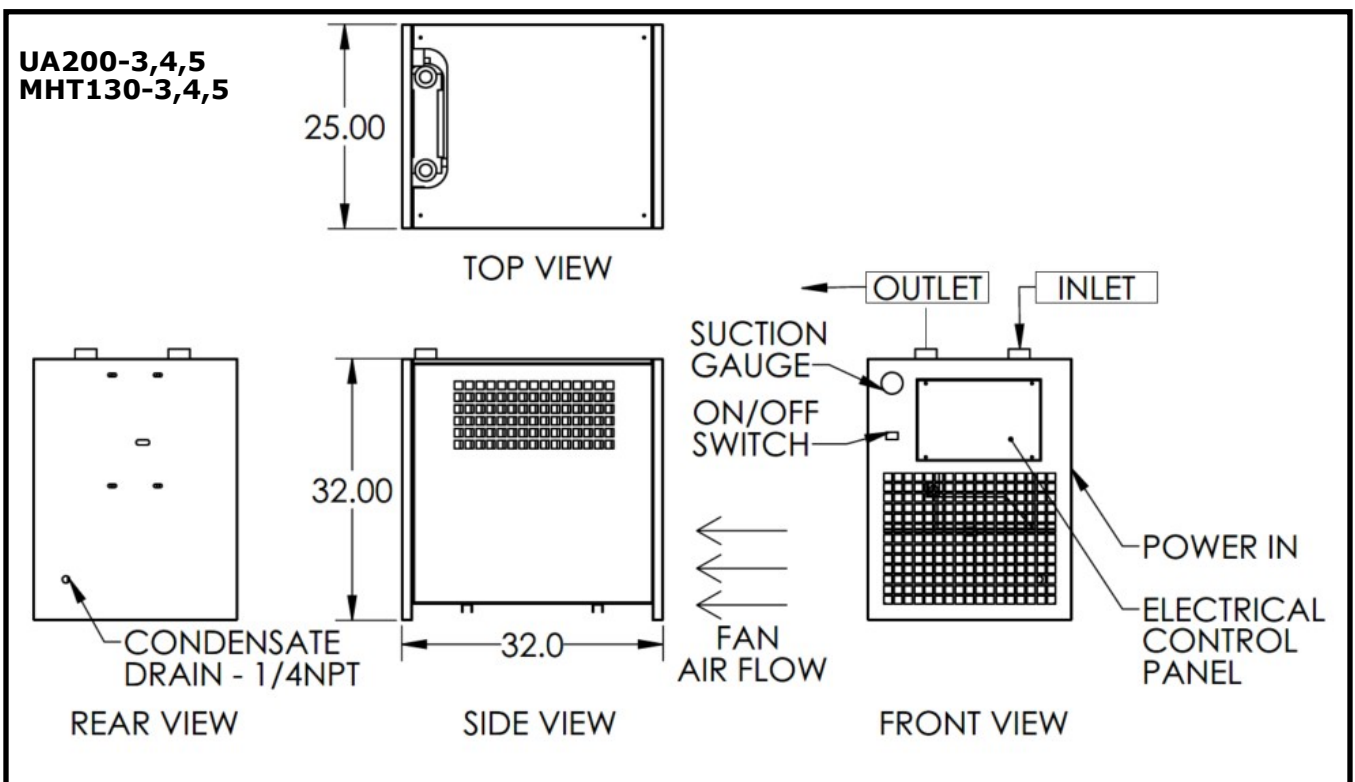
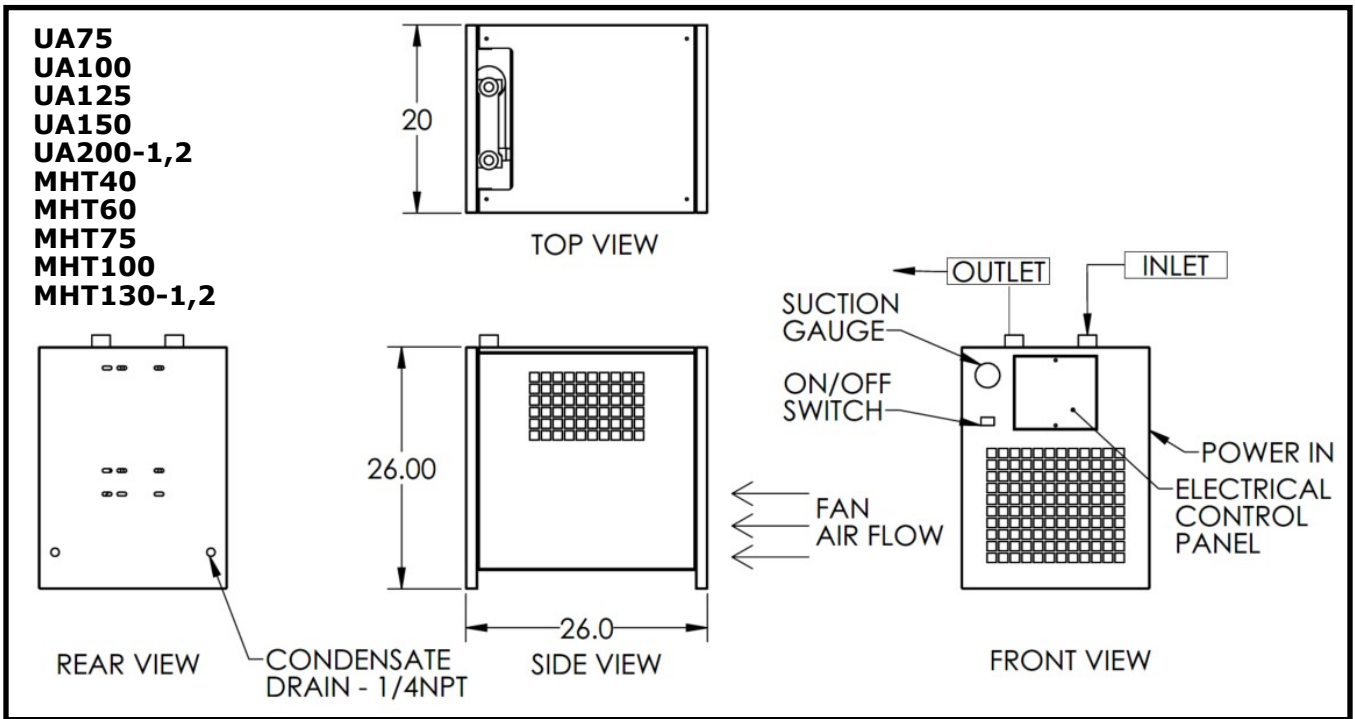

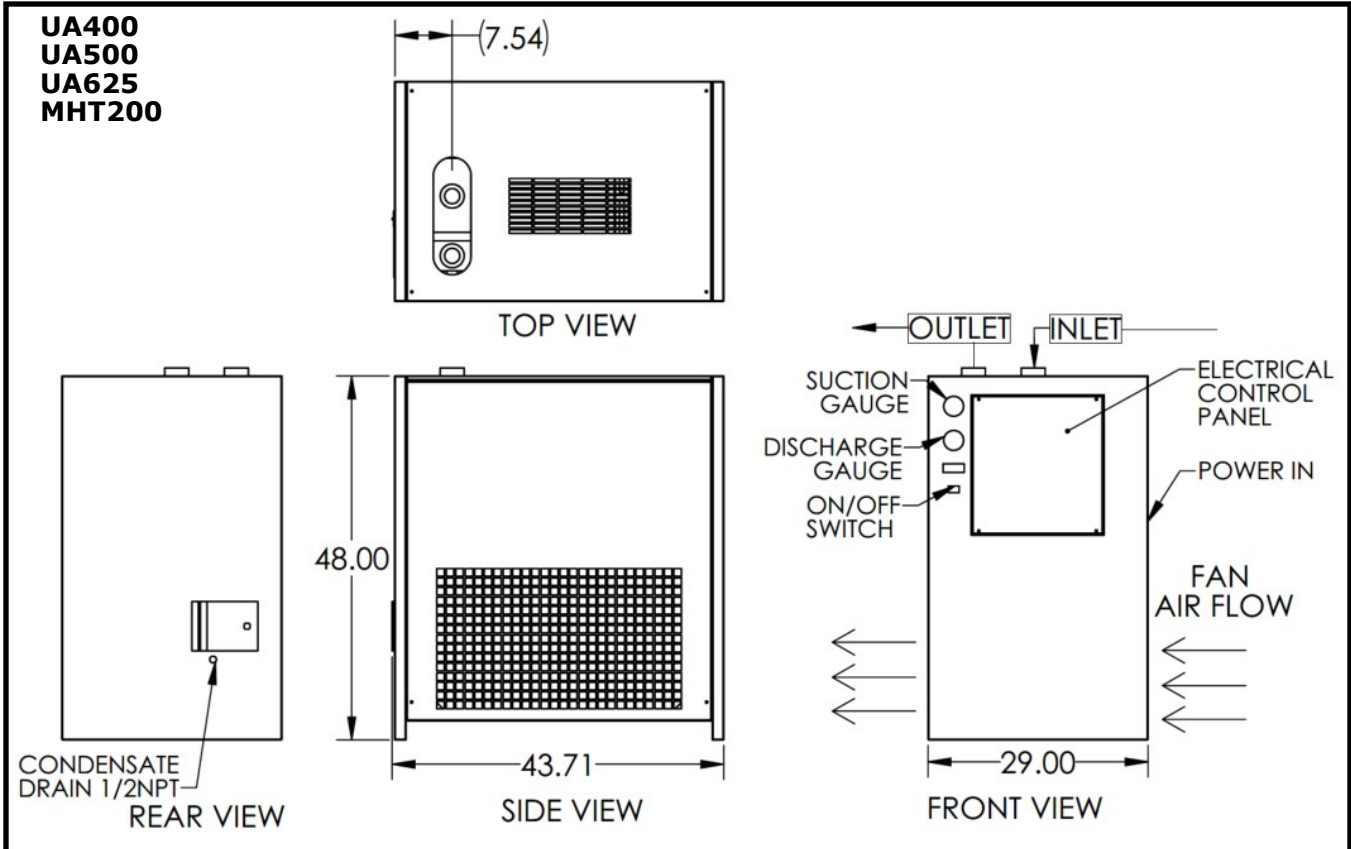
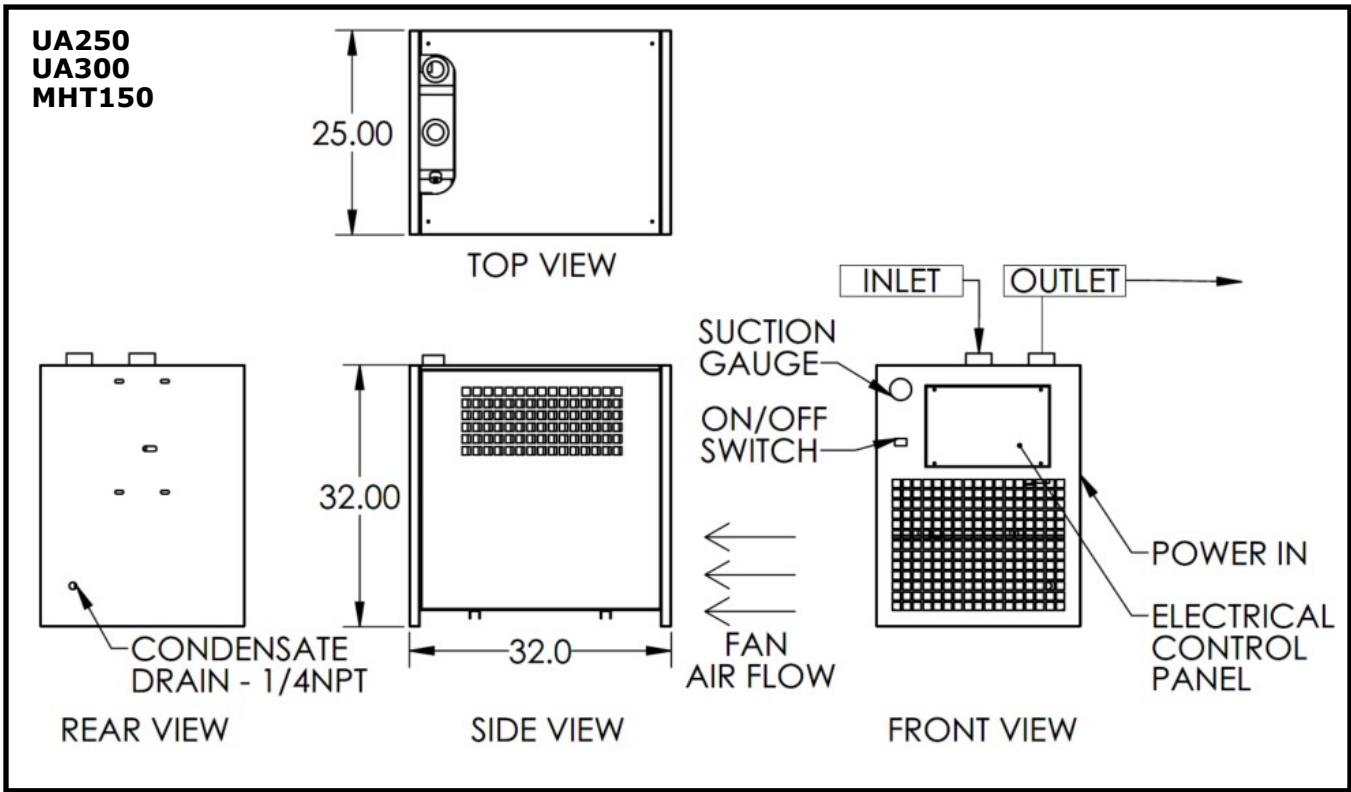

**UA800
UA1000
UA1200**

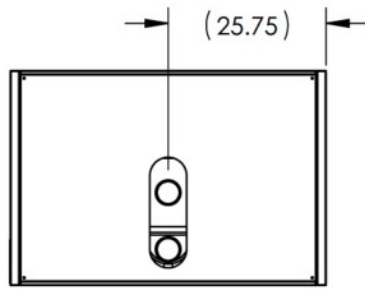

TOP VIEW

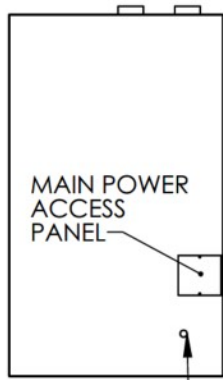

REAR VIEW

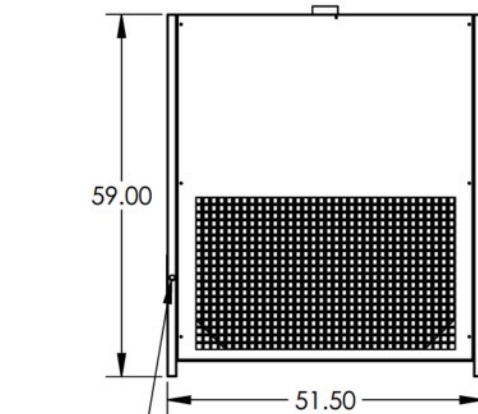

SIDE VIEW

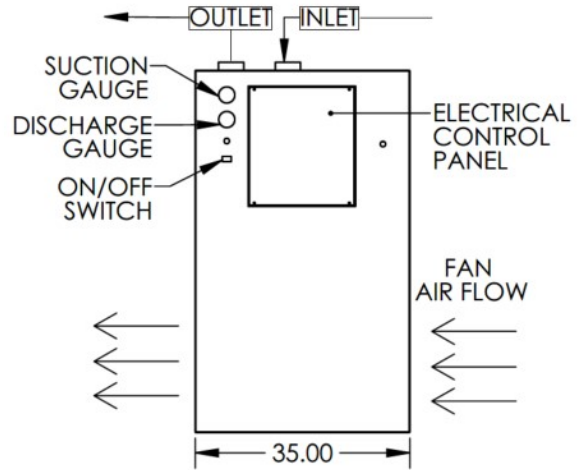

FRONT VIEW

**UA1600
UA2000**

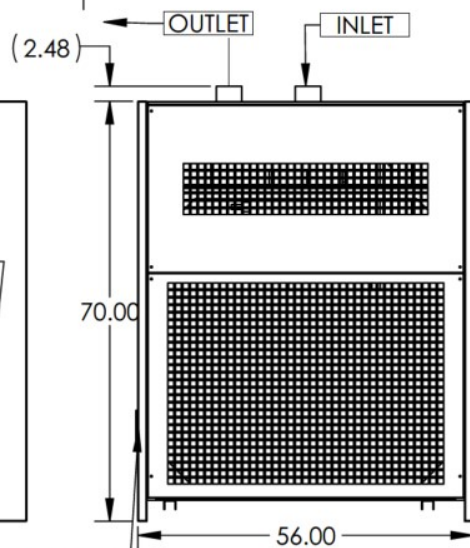
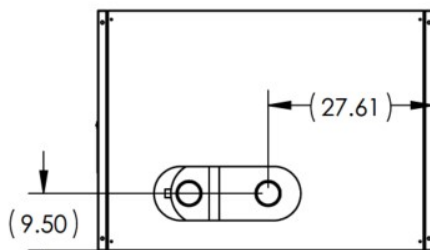

SIDE VIEW

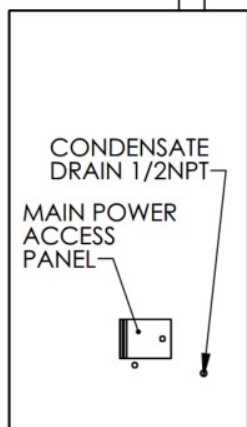

REAR VIEW

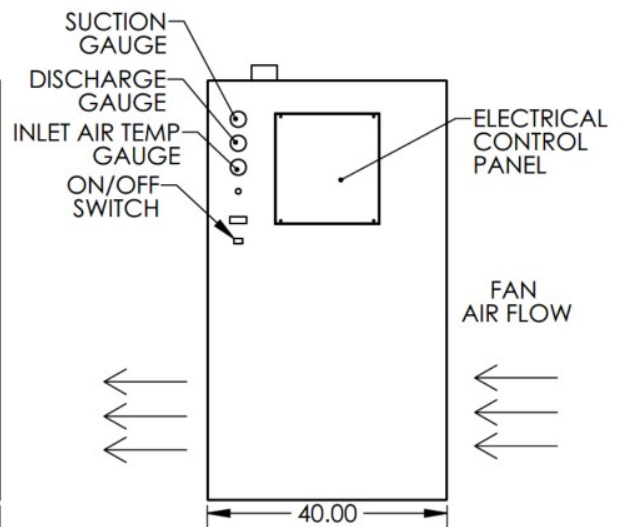

FRONT VIEW

DATA LABEL—UA Series

Note - Data below is for reference only and is subject to change. Please refer to the label on your unit for the most up to date information.

Model	Voltage	RLA	LRA	MCA	MCP	Max Inlet Air Temp - F	Min/Max Ambient Temp - F	Ref. System Design - PSIG	Suction / Discharge - PSIG	Ref. Compressor HP	Refrigerant Type	Refrigerant Charge	Max Air Pressure PSIG	Drain Port NPT	Inlet / Outlet Port NPT
UA20A-1	115v-1ph-60hz	1.91	14.4	2.8	15	110	45/110	150/300	30/115	1/6	R134A	8 oz	232	3/8	1/2
UA25A-1	115v-1ph-60hz	4.91	27.5	6.7	15	110	45/110	150/300	30/115	1/4	R134A	8 oz	232	3/8	1/2
UA40A-1	115v-1ph-60hz	4.91	27.5	6.7	15	110	45/110	150/300	30/115	1/4	R134A	9 oz	232	3/8	3/4
UA55A-1	115v-1ph-60hz	4.91	27.5	6.7	15	110	45/110	150/300	30/115	1/4	R134A	9 oz	232	3/8	3/4
UA75A-1	115v-1ph-60hz	5.82	32	7.86	15	110	45/110	150/300	30/115	1/3	R134A	8 oz	232	1/4	1
UA75A-2	230v-1ph-60hz	4.8	23	6.3	15	110	45/110	150/450	30/115	1/2	R134A	8 oz	232	1/4	1
UA100A-1	115v-1ph-60hz	9.5	48	12.3	20	110	45/110	150/450	30/115	1/2	R134A	10 oz	232	1/4	1
UA100A-2	230v-1ph-60hz	4.8	23	6.3	15	110	45/110	150/450	30/115	1/2	R134A	10 oz	232	1/4	1
UA125A-1	115v-1ph-60hz	9.5	48	12.3	20	110	45/110	150/450	30/115	1/2	R134A	10 oz	232	1/4	1
UA125A-2	230v-1ph-60hz	4.8	23	6.3	15	110	45/110	150/450	30/115	1/2	R134A	10 oz	232	1/4	1
UA150A-1	115v-1ph-60hz	13	69	17.1	30	110	45/110	150/450	30/115	3/4	R134A	15 oz	232	1/4	1 1/2
UA150A-2	230v-1ph-60hz	7	41.8	9.2	15	110	45/110	150/450	30/115	3/4	R134A	15 oz	232	1/4	1 1/2
UA200A-1	115v-1ph-60hz	13	69	17.1	30	110	45/110	150/450	30/115	3/4	R134A	15 oz	232	1/4	1 1/2
UA200A-2	230v-1ph-60hz	7	41.8	9.2	15	110	45/110	150/450	30/115	3/4	R134A	15 oz	232	1/4	1 1/2
UA200A-3	230v-3ph-60hz	6.7	51	9.9	15	110	45/110	181/450	30/115	1 1/2	R404A	2 lbs 5 oz	232	1/4	1 1/2
UA200A-4	460v-3ph-60hz	3.9	25	5.4	15	110	45/110	181/450	70/225	1 1/2	R404A	2 lbs 5 oz	232	1/4	1 1/2
UA250A-2	230v-1ph-60hz	7	41	9.5	15	110	45/110	150/235	30/115	1	R134A	2 lbs	232	1/4	2
UA250A-3	230v-3ph-60hz	6.7	51	9	15	110	45/110	181/450	70/225	1 1/2	R404A	2 lbs 5 oz	232	1/4	2
UA250A-4	460v-3ph-60hz	3.9	25	5.4	15	110	45/110	181/450	70/225	1 1/2	R404A	2 lbs 5 oz	232	1/4	2
UA300A-2	230v-1ph-60hz	7	41	9.5	15	110	45/110	150/235	30/115	1	R134A	2 lb	232	1/4	2
UA300A-3	230v-3ph-60hz	6.7	51	9.1	15	110	45/110	181/450	70/225	1 1/2	R404A	2 lbs 5 oz	232	1/4	2
UA300A-4	460v-3ph-60hz	3.9	25	5.4	15	110	45/110	181/450	70/225	1 1/2	R404A	2 lbs 5 oz	232	1/4	2
UA300A-5	575v-3ph-60hz	3.1	20	4.9	15	110	45/110	181/450	70/225	1 1/2	R404A	2 lbs 5 oz	232	1/4	2
UA400A-3	230v-3ph-60hz	10.1	58	12.6	20	110	45/110	181/450	70/225	2	R404A	5 lbs	232	1/4	2
UA400A-4	460v-3ph-60hz 400v-3ph-50hz	6.5	38	9.1	15	110	45/110	181/450	70/225	2	R404A	5 lbs	232	1/4	2
UA500A-3	230v-3ph-60hz	12.8	73	16	30	110	45/110	150/350	70/225	3	R404A	5 lbs	232	1/4	2
UA500A-4	460v-3ph-60hz	6.5	38	9.1	15	110	45/110	181/450	70/225	3	R404A	5 lbs	232	1/4	2
UA625A-3	230v-3ph-60hz	12.8	73	16	30	110	45/110	181/450	70/225	3	R404A	5 lbs	232	1/4	2 1/2
UA625A-4	460v-3ph-60hz	6.5	38	9.1	15	110	45/110	181/450	70/225	3	R404A	5 lbs	232	1/4	2 1/2
UA625A-5	575v-3ph-60hz	4.8	30.4	7.3	15	110	45/110	181/450	70/225	3	R404A	5 lbs	232	1/4	2 1/2
UA800A-3	230v-3ph-60hz	16.5	103	23.7	40	110	45/110	181/450	70/225	4	R404A	9 lbs	232	1/2	3
UA800A-4	460v-3ph-60hz	9	62	13.5	20	110	45/110	181/450	70/225	4	R404A	9 lbs	232	1/2	3
UA800A-5	575v-3ph-60hz	7.2	50	10.8	15	110	45/110	181/450	70/225	4	R404A	9 lbs	232	1/2	3
UA1000A-3	230v-3ph-60hz	20	114	25	50	110	45/110	181/450	70/225	6	R404A	9 lbs	232	1/2	3
UA1000A-4	460v-3ph-60hz	10	52	14	20	110	45/110	181/450	70/225	6	R404A	9 lbs	232	1/2	3
UA1000A-5	575v-3ph-60hz	8	42	11.2	20	110	45/110	181/450	70/225	6	R404A	9 lbs	232	1/2	3
UA1200A-3	230v-3ph-60hz	20	114	25	50	110	45/110	181/450	70/225	6	R404A	9 lbs	232	1/2	3
UA1200A-4	460v-3ph-60hz	10	52	14	20	110	45/110	181/450	70/225	6	R404A	9 lbs	232	1/2	3
UA1200A-5	575v-3ph-60hz	8	42	11.2	20	110	45/110	150/350	70/225	6	R404A	9 lbs	232	1/2	3
UA1600A-4	460v-3ph-60hz	17.9	95	23	40	110	45/110	181/450	70/225	8	R404A	18 lbs	232	1/2	4
UA1600A-5	575v-3ph-60hz	14.3	76	18	30	110	45/110	181/450	70/225	8	R404A	18 lbs	232	1/2	4
UA2000A-4	460v-3ph-60hz	25.6	150	32	60	110	45/110	181/450	70/225	10	R404A	20 lbs	232	1/2	4
UA2000A-5	575v-3ph-60hz	20.5	120	25.6	45	110	45/110	181/450	70/225	10	R404A	20 LBS	232	1/2	4

DATA LABEL—MHT Series

Note - Data below is for reference only and is subject to change. Please refer to the label on your unit for the most up to date information

Model	Voltage	RLA	LRA	Min. Circuit Amp	Max Fuse Size	Max Inlet Air Temp - F	Min/Max Ambient Temp - F	Ref. System Design - PSIG	Suction / Discharge - PSIG	Ref. Compressor HP	Refrigerant Type	Refrigerant Charge	Max Air Pressure PSIG	Drain Port NPT	Inlet / Outlet Port NPT
MHT25-1	115v-1ph-60hz	4.91	27.5	6.7	15	180	45/110	150/300	30/115	1/4	R134A	9 oz	232	3/8	3/4
MHT40-1	115v-1ph-60hz	5.82	32	7.86	15	180	45/110	150/300	30/115	1/3	R134A	8 oz	232	1/4	1
MHT40-2	230v-1ph-60hz	4.8	23	6.3	15	180	45/110	150/450	30/115	1/2	R134A	8 oz	232	1/4	1
MHT60-1	115v-1ph-60hz	9.5	48	12.3	20	180	45/110	150/450	30/115	1/2	R134A	10 oz	232	1/4	1
MHT60-2	230v-1ph-60hz	4.8	23	6.3	15	180	45/110	150/450	30/115	1/2	R134A	10 oz	232	1/4	1
MHT75-1	115v-1ph-60hz	9.5	48	12.3	20	180	45/110	150/450	30/115	1/2	R134A	10 oz	232	1/4	1
MHT75-2	230v-1ph-60hz	4.8	23	6.3	15	180	45/110	150/450	30/115	1/2	R134A	10 oz	232	1/4	1
MHT100-1	115v-1ph-60hz	13	69	17.1	30	180	45/110	150/450	30/115	3/4	R134A	15 oz	232	1/4	1 1/2
MHT100-2	230v-1ph-60hz	7	41.8	9.2	15	180	45/110	150/450	30/115	3/4	R134A	15 oz	232	1/4	1 1/2
MHT130-2	230v-1ph-60hz	7	41.8	9.2	15	180	45/110	150/450	30/115	3/4	R134A	15 oz	232	1/4	1 1/2
MHT130-3	230v-3ph-60hz	6.7	51	9.9	15	180	45/110	181/450	30/115	1 1/2	R404A	2 lbs 5 oz	232	1/4	1 1/2
MHT130-4	460v-3ph-60hz	3.9	25	5.4	15	180	45/110	181/450	70/225	1 1/2	R404A	2 lbs 5 oz	232	1/4	1 1/2
MHT150-2	230v-1ph-60hz	7	41	9.5	15	180	45/110	150/235	30/115	1	R134A	2 lb	232	1/4	2
MHT150-3	230v-3ph-60hz	6.7	51	9.1	15	180	45/110	181/450	70/225	1 1/2	R404A	2 lbs 5 oz	232	1/4	2
MHT150-4	460v-3ph-60hz	3.9	25	5.4	15	180	45/110	181/450	70/225	1 1/2	R404A	2 lbs 5 oz	232	1/4	2
MHT150-5	575v-3ph-60hz	3.1	20	4.9	15	180	45/110	181/450	70/225	1 1/2	R404A	2 lbs 5 oz	232	1/4	2
MHT200-3	230v-3ph-60hz	10.1	58	12.6	20	180	45/110	181/450	70/225	2	R404A	5 lbs	232	1/4	2
MHT200-4	460v-3ph-60hz	6.5	38	9.1	15	180	45/110	181/450	70/225	2	R404A	5 lbs	232	1/4	2

ELECTRICAL SCHEMATICS

UA20A; UA25A; UA40A; UA55A
MHT25A
(SINGLE PHASE)

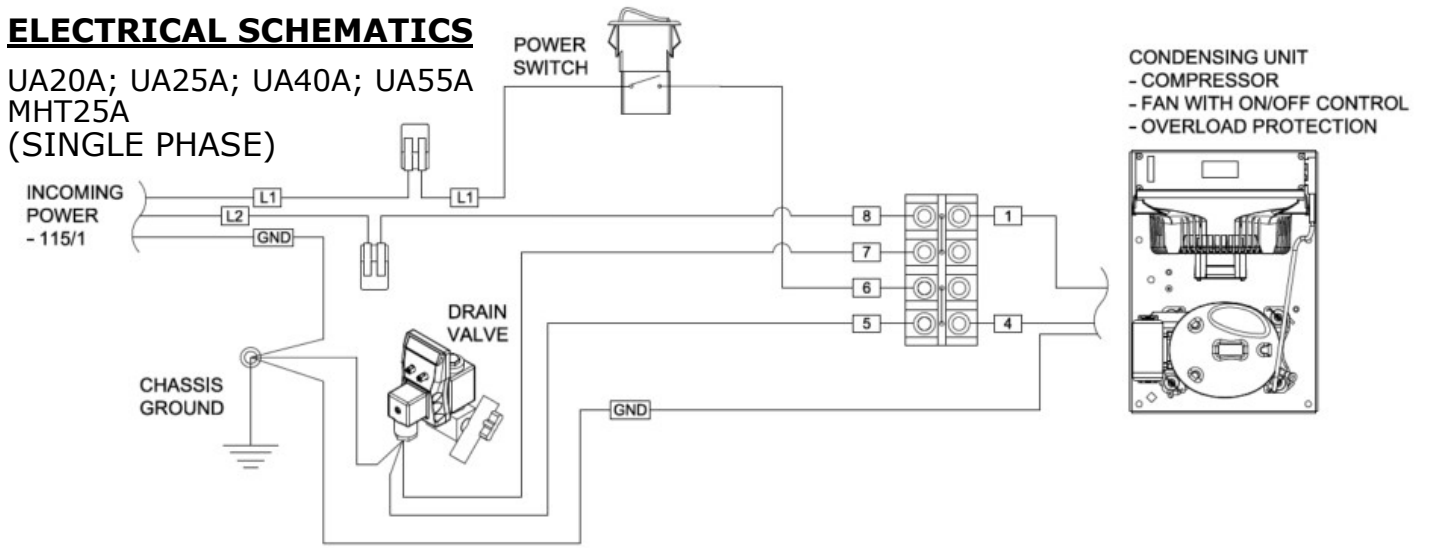

UA75A; UA100A; UA125A
MHT40A; MHT60A; MHT75A
(SINGLE PHASE)

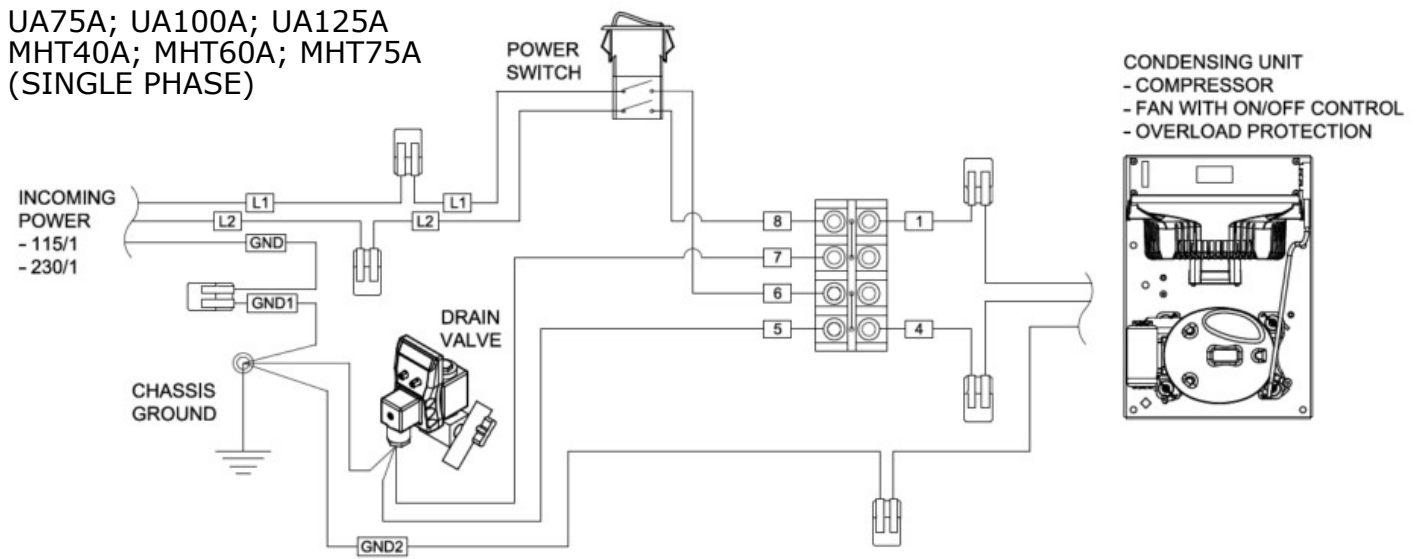

UA150A; UA200A; UA250A; UA300A
MHT100A; MHT130A; MHT150A
(SINGLE PHASE)

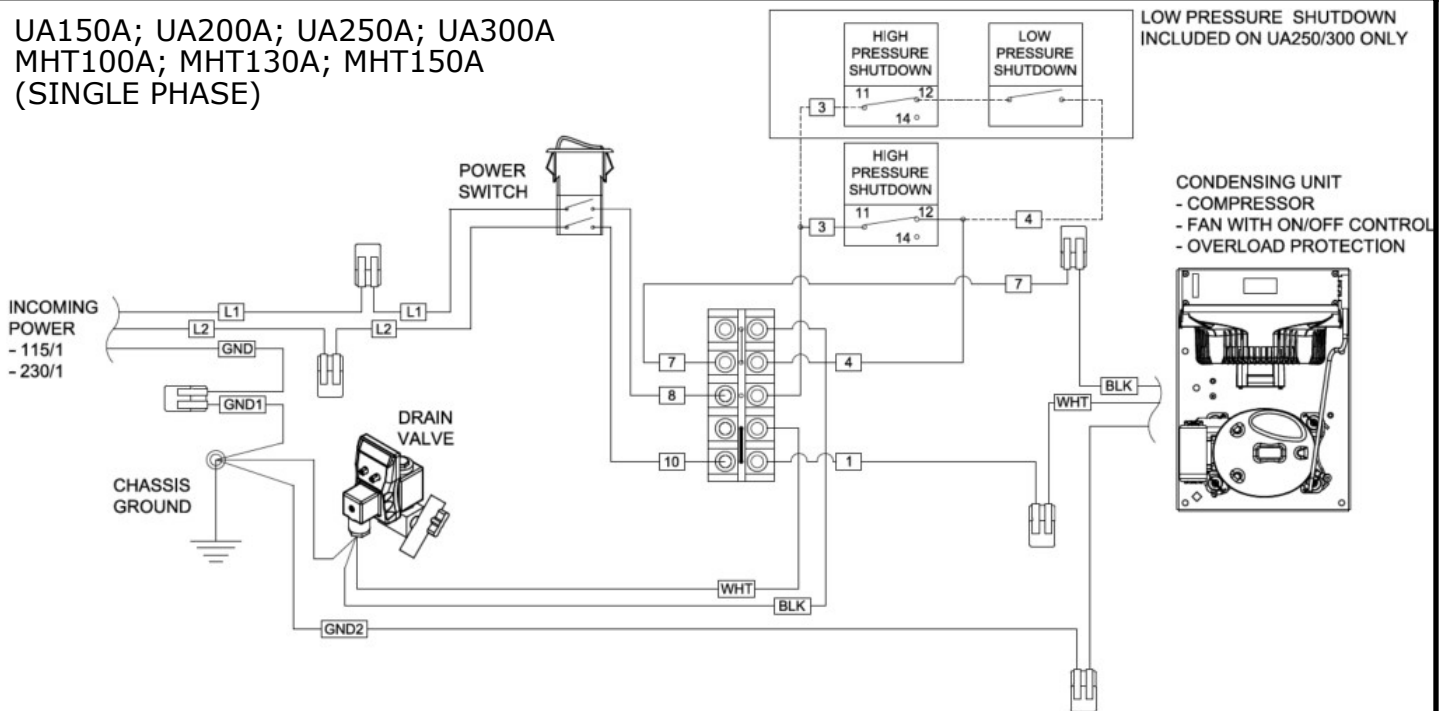

ELECTRICAL SCHEMATICS

UA200A
UA250A
UA300A

MHT130A
MHT150A

(460-575VAC/3PH)

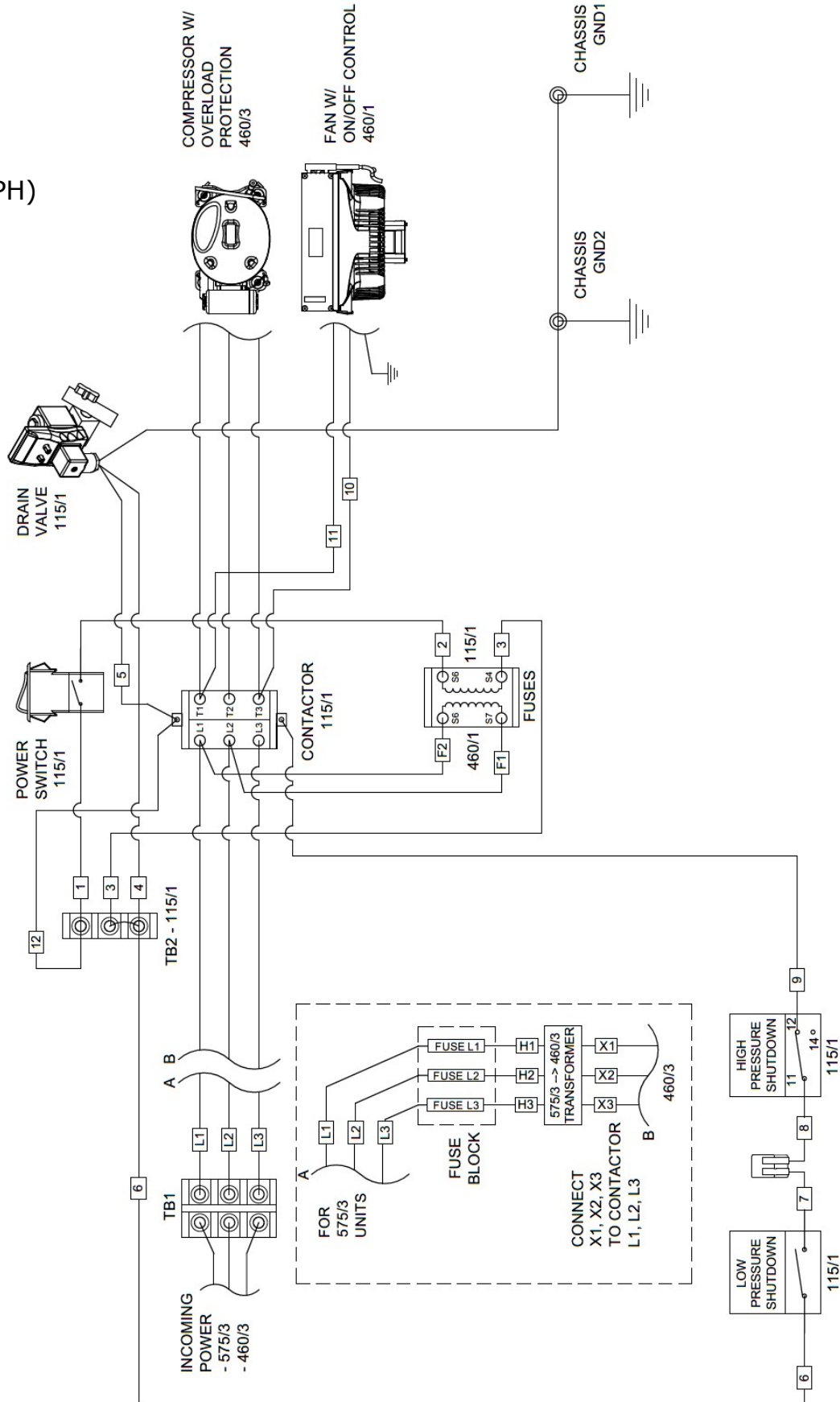

ELECTRICAL SCHEMATICS

UA200A
 UA250A
 UA300A

MHT130A
 MHT150A

(230VAC/3PH)

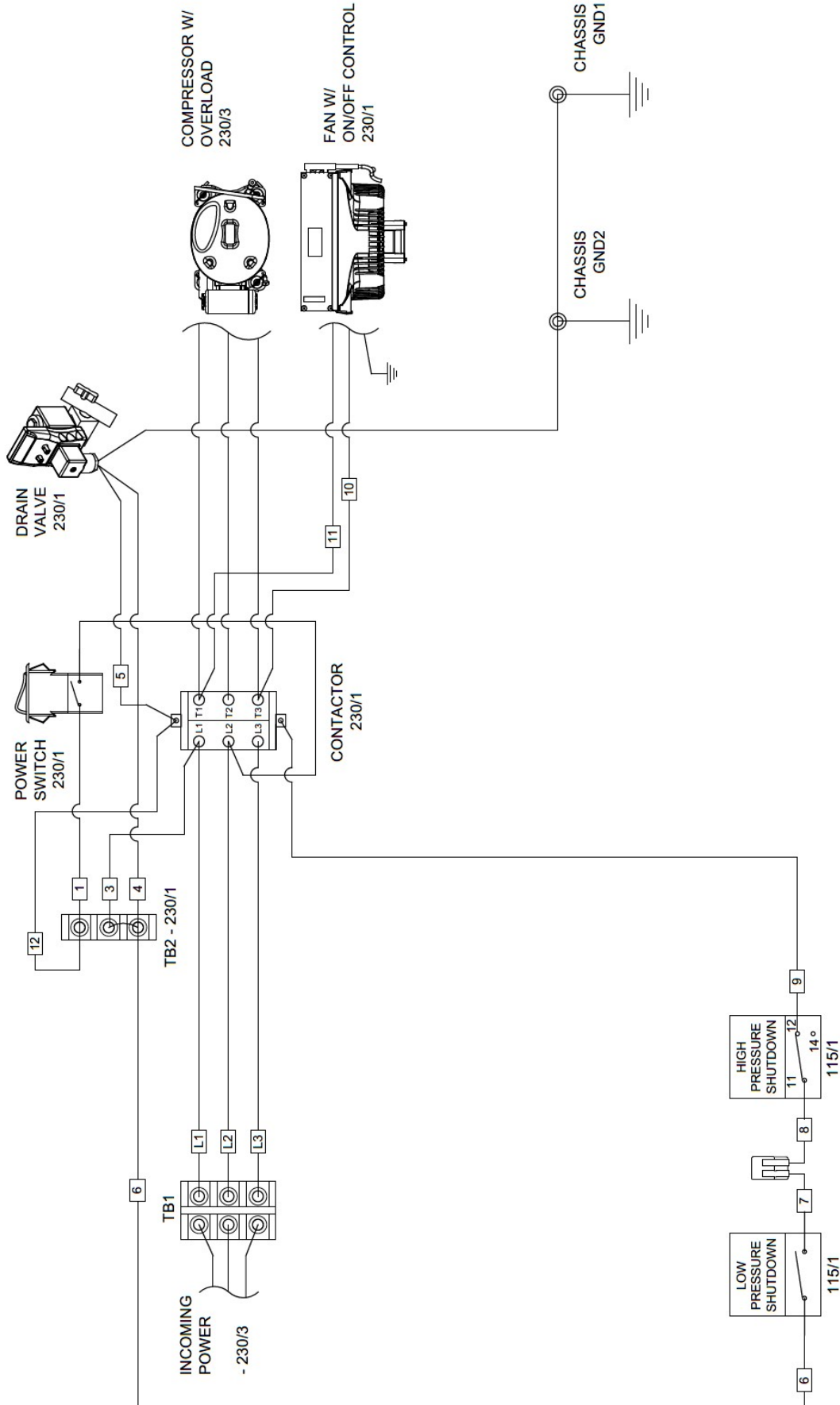

ELECTRICAL SCHEMATICS

UA400A
 UA500A
 UA625A
 UA800A
 UA1000A
 UA1200A

MHT200A

(460-575VAC/3PH)

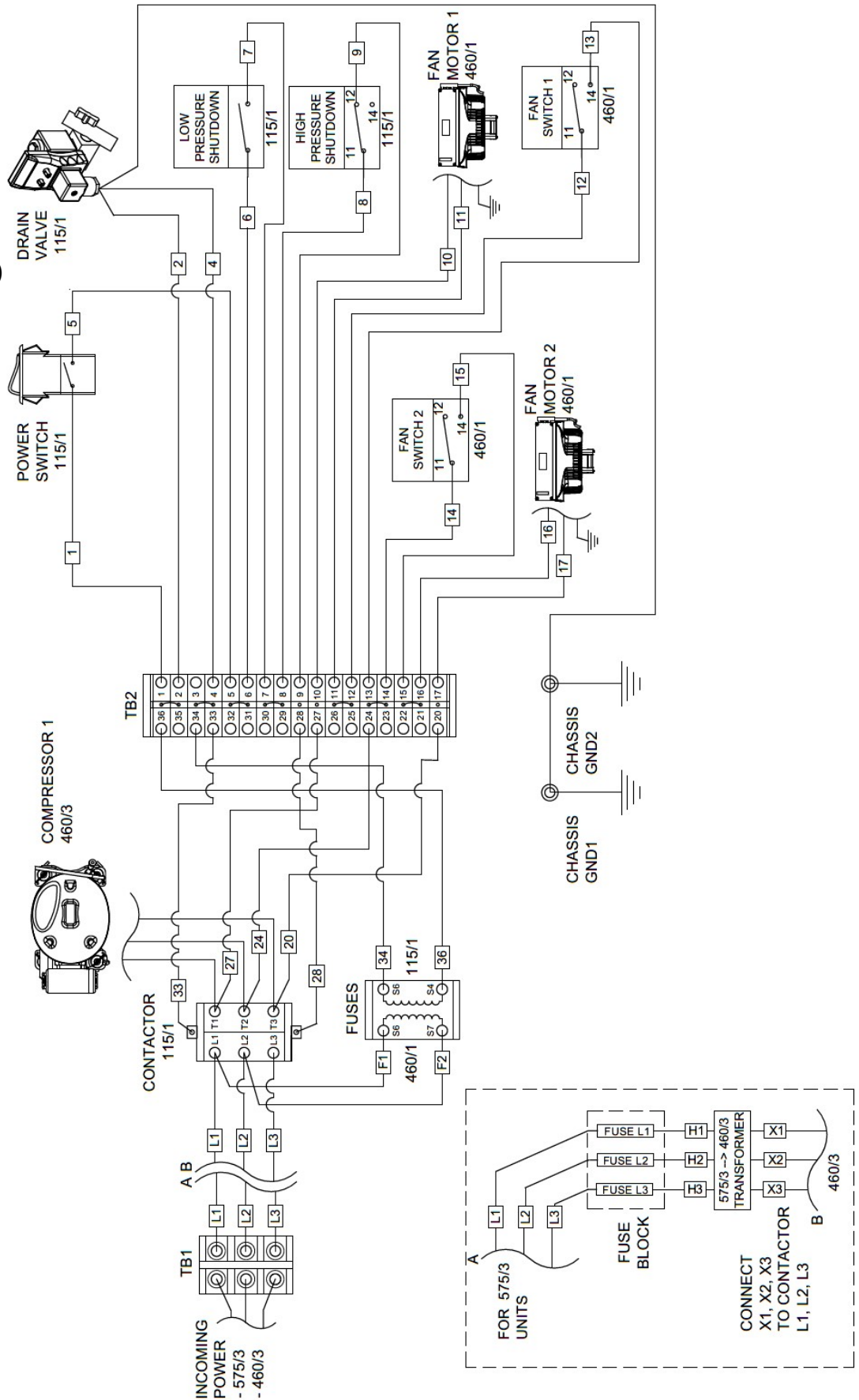

ELECTRICAL SCHEMATICS

UA400A
 UA500A
 UA625A
 UA800A
 UA1000A
 UA1200A

MHT200A

(230VAC/3PH)

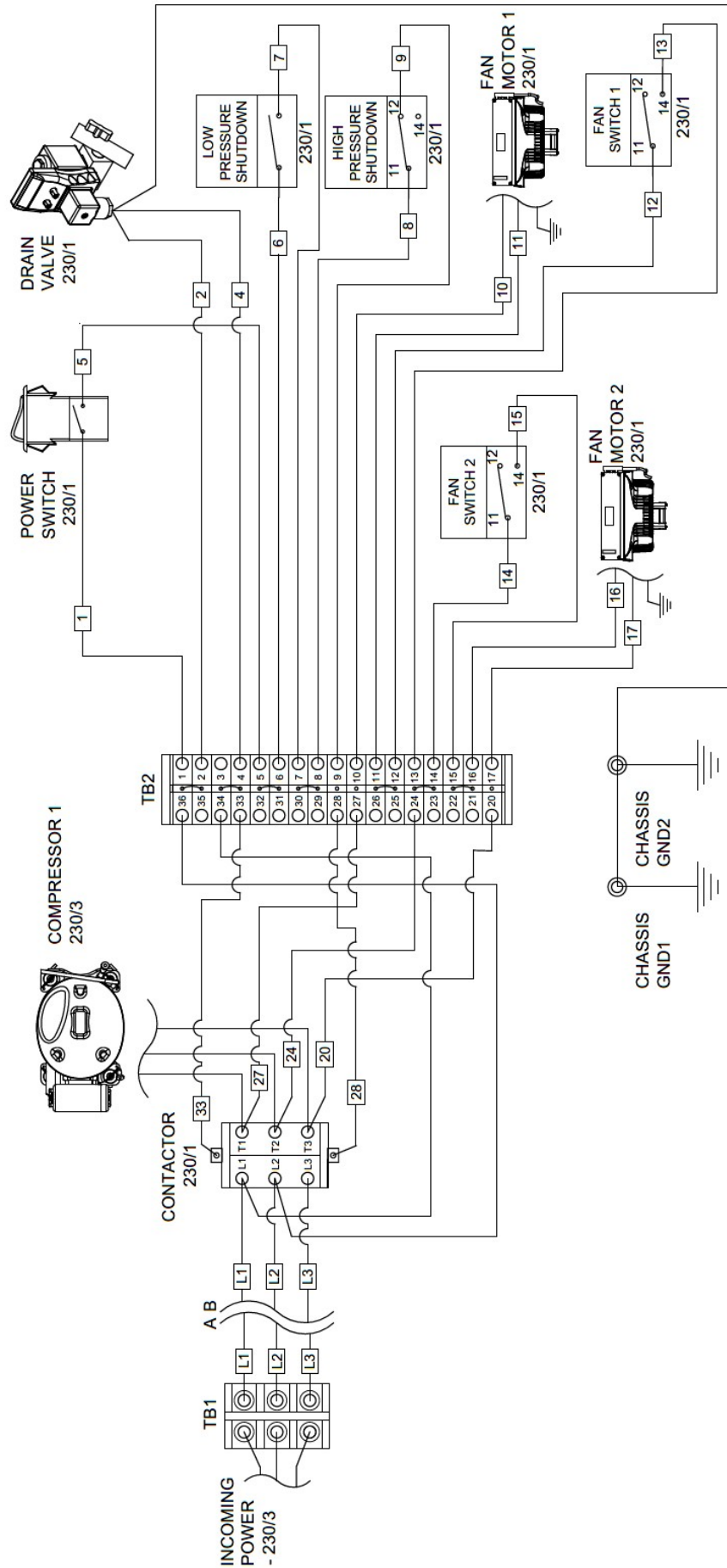

ELECTRICAL SCHEMATICS

UA1600A
UA2000A

(THREE PHASE)

